

# Centrifugal Fans belt driven

**NICOTRA** | Gebhardt





**Nicotra Gebhardt S.p.A.** (Italy) certifies that ADH-E fans of the E0, E2, E4, E6 and E7 versions, from sizes 0160 to 0560, RDH-E fans of the E0, E2, E4, E6 and E7 versions, from sizes 0180 to 0560, ADH and RDH fans of the L, R, K, K1 and K2 versions, from sizes 0630 to 1000, shown herein are licensed to bear the AMCA Seal.

**Nicotra Gebhardt GmbH** (Germany) certifies that RZR fans of the 11, 12, 15 versions, from sizes 0355 to 1000, shown herein are licensed to bear the AMCA Seal.

The ratings shown are based on tests and procedures performed in accordance with AMCA Publication 211 and comply with the requirements of the AMCA Certified Ratings Program.

Air performance with Installation Type “A” (“with free outlet”) and that of the twin versions G2L, G2R, G2K, G2K2, G2E0, G2E2, G2E4, G2E7 in any installation type is not AMCA licensed.

## Nicotra Gebhardt stands for:



- Maximised flexibility and minimised design effort for customers, because all radial fan casings have identical dimensions – no matter what kind of impeller geometry



- Top product quality and shorter delivery times – thanks to state-of-the-art production technology

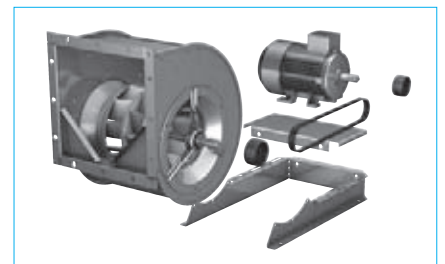

- Energy efficiency through comprehensive system know-how

A strong provider for many optimal solutions:

## The Nicotra-Gebhardt portfolio

When it comes to radial fans, we are the first people you should talk to. From belt-driven radial fans to plugfans, it's all there in our product portfolio. We offer the largest, most comprehensive range of products in this area – and of course the matching services.

**ADH-E / ADH**



double-inlet  
forward-curved impeller geometry

**RDH-E / RDH**



double-inlet  
backward-curved impeller geometry

**RZR *rotavent***



double-inlet  
hollow aerofoil impeller geometry

When everything fits:

## 100% compatible product series

To us, perfection in our product portfolio means that all product series in the area of encased radial fans are attuned to one another and are 100% compatible in their dimensions.

How did we do it?

By using an identical design for the connection dimensions of every fan size in our newly developed series ADH-E and RDH-E and carefully coordinating our options and accessories.

In this way, we have standardised and harmonised our product portfolio in all relevant areas.

Well designed, easy to install, economical –

## The compact base frame from Nicotra-Gebhardt

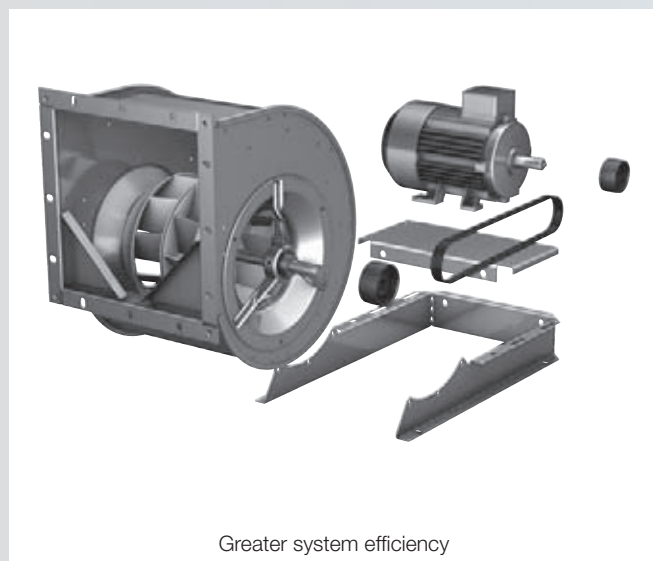

A system that saves space, time, and money – in an air handling unit or any other application: our compact base frame offers decisive advantages:

- The frame lengths have been optimised and adjusted for the casing position and motor installation height to achieve the smallest possible overall height and length
- Exact, optimised coordination of all components, all the way through to installation, adjustment and testing
- Suitable for all fans of the series ADH-E0, RDH-E0 and RZR-11 up to size 0500

# proSELECTA II

**proSELECTA II** is a technical selection program that allows you to configure your own individually designed fan. It provides you with the opportunity to choose from the entire range of fan types and their associated options.

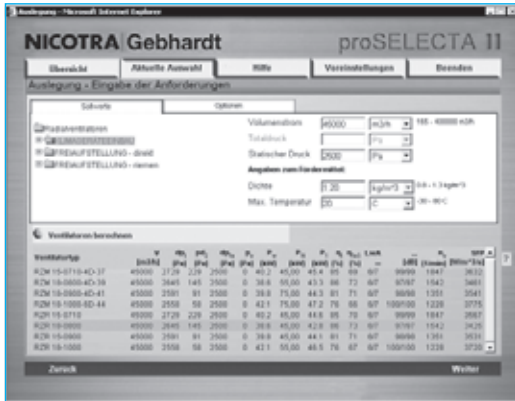

## Simple and reliable selection

The result from **proSELECTA II** is the provision of all the technical data for your fan, including sound level data, dimension specifications and accessories. Apart from that, as a registered user, your purchase prices are provided. Additionally fully dimensioned drawings in DXF format are available, which can be downloaded and transferred straight into your CAD system.

## So that you can be sure

Models and options that are technically not permissible, are automatically excluded in proSELECTA II. So there is no chance that you will configure a “wrong” device option.

## What else is important to you

During the fan selection process, you can choose any of the standardised ATEX options.

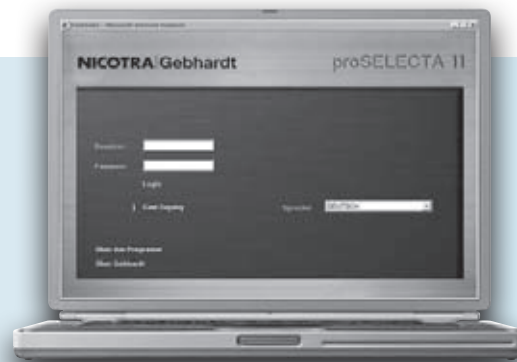

## Free registration and many advantages

You can register as a proSELECTA II user with us, which enables us to offer you faster order processing. What this means for you is:

- The complete configuration of your fan with its associated system accessories and belt drive layout.
- The possibility to produce fans that operate via a frequency inverter.
- The option of saving your own fan configuration on our server.
- The opportunity to modify your saved configuration, even over the phone to your Nicotra-Gebhardt representative.

### High performance centrifugal fan ADH

- double inlet for belt drive
- impeller with forward curved blades of galvanised sheet steel

- Volume up to 300,000 m<sup>3</sup>/h
- Pressure up to 2,200 Pa

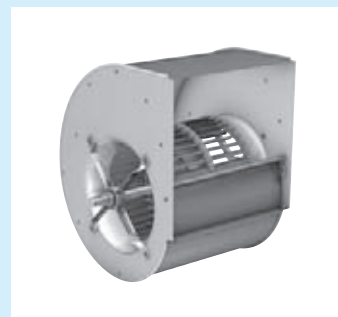

ADH

### High performance centrifugal fan RDH

- double inlet for belt drive
- centrifugal impeller with backward inclined blades

- Volume up to 290,000 m<sup>3</sup>/h
- Pressure up to 3,500 Pa

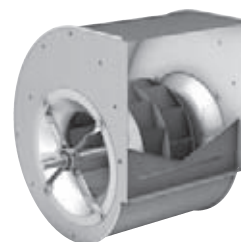

RDH

### High performance centrifugal fan RZR *rotavent*

- double inlet for belt drive
- high performance impeller with backward curved hollow section true aerofoil blades

- Volume up to 300,000 m<sup>3</sup>/h
- Pressure up to 3,500 Pa

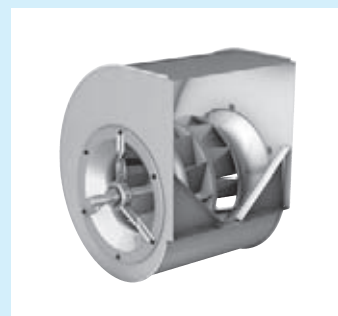

RZR

### Fittings / Accessories

- complete system accessories
- miscellaneous fittings

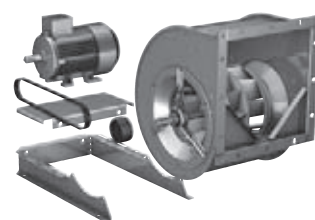

Accessories

### Description

- technical description
- operating limits

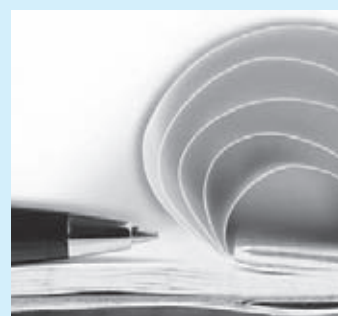

Description

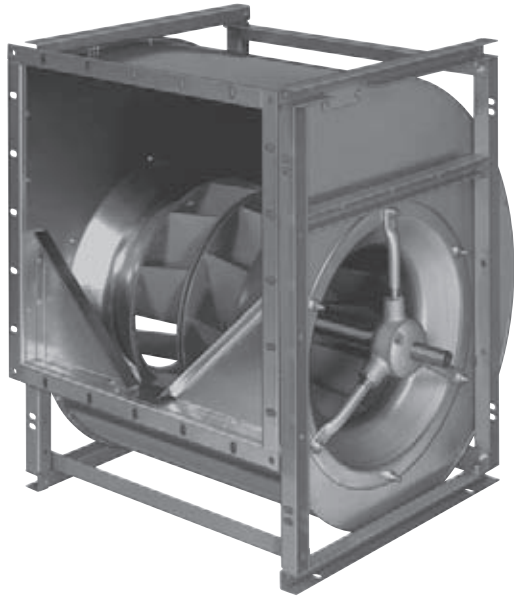

**Highest system performance and best energy efficiency:  
The *rotavent* RZR series**

It is not difficult to make a centrifugal fan for an air conditioning unit a few euros cheaper.

But to construct it so that it saves valuable energy during operation is a real technological challenge.

In this respect, the *rotavent* from Nicotra Gebhardt continues to provide the technology with the highest level of system performance and with that, the best solution where energy efficiency counts.

*rotavent* – the efficient fan technology with centrifugal impeller and airfoil blades.

**Top quality for performance and a long service life!**

**The advantages:**

- Wide range of application even for high pressures
- Easy adaption to changed operating conditions thanks to the belt drive
- Easy and reliable layout, performance data complying with tolerance class 1
- High degree of performance density at the best efficiency
- Low level of noise thanks to the blade profile, a patented blade positioning and the V-cut off
- Easy selection via the proSELECTA II electronic catalogue
- 

**We do it very precisely!**

**Or**

**Why you should not compare apples with pears!**

Nicotra-Gebhardt manufactures its centrifugal fans *rotavent* with tolerance class 1 in compliance with DIN 24166.

This gives you the necessary degree of security that you need when designing and planning ventilation installations. The tolerance class is also an important criterion for the objective comparison of fans.

If you compare the price/performance ratio of two fans, you should also always take the tolerance class of each into account, only then do you avoid comparing "apples with pears"!

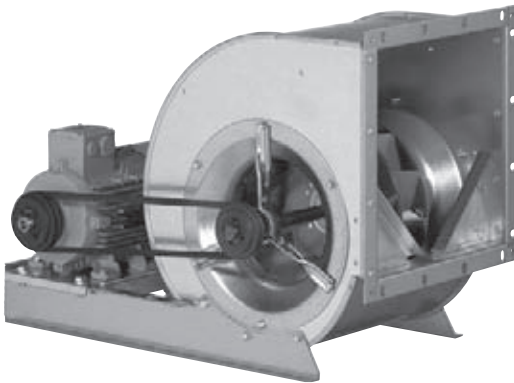

Performance data		Deviations per tolerance class		
		1	2	3
Volume flow	$q_V$	2.5 %	5 %	10 %
Pressure increase	$p_F$	2.5 %	5 %	10 %
Power consumption	$P$	+3 %	+8 %	+16 %
Efficiency	$\eta$	-2 %	-5 %	-
Sound power level (A weighted)	$L_{WA}$	+3 dB	+4 dB	+6 dB

**Variety has a name:  
RZR rotavent**

rotavent fans, double inlet with patented impeller geometry and tapered trailing airfoil blades are the leading edge for standard fans for ventilation and air conditioning units.

**Series RZR rotavent**





- Sizes 0200/-1600
- Lap jointed scroll of galvanised sheet steel with V-Cut off (RZR 11; 12; 14; 15; 18)
- Scroll casing stitch welded and coated, with V-cut off (RZR 13; 19)
- Centrifugal impeller with 11 backward inclined steel blades, welded and coated (0200/-0280)
- High performance impeller with 12 hollow section true airfoil blades (0315/-1600)





**Series RZR rotavent**

- Volume up to 300,000 m<sup>3</sup>/h
- Pressure up to 3,500 Pa

**The RZR rotavent range of models:  
The right fan for every specification!**

Depending on the fan size, the RZR series have up to 7 mechanical versions of the single fan. In this way, we ensure that we have the perfect model for all requirements and any application.

Version	Description	Figure
RZR 11-0200/-0710	Lap jointed scroll with multi-position feet and discharge flange. Light duty bearing execution with pressed steel housing/strut assemblies.	
RZR 12-0200/-0710	Lap jointed scroll with rectangular side frame and discharge flange. Light duty bearing execution with pressed steel housing/strut assemblies.	
RZR 14-0315/-1000	Lap jointed scroll with heavy duty reinforced side frames and discharge flange. Medium duty bearing execution with cast iron pillow block, mounted on a robust pedestal.	
RZR 15-0400/-1000	Lap jointed scroll with heavy duty reinforced side frames and discharge flange. Medium-heavy duty bearing execution with cast iron housing/strut assemblies.	
RZR 18-0400/-1000	Lap jointed scroll with discharge flange and heavy duty reinforced side frames. Heavy duty bearing execution with split-type plummer block, mounted on robust pedestal.	

Version	Description	Figure
RZR 19-0200/-0355	Scroll casing stitch welded with discharge flange and multi-position feet. Medium-heavy bearing execution with cast iron housing and tubular struts.	
RZR 19-0400/-1000	Scroll casing stitch welded with discharge flange, and heavy duty reinforced side frames, epoxy coated. Medium-heavy bearing execution with cast iron housing and tubular struts.	
RZR 13-0400/-1000	Scroll casing stitch welded with discharge flange and heavy duty reinforced side frames, epoxy coated. Heavy duty bearing execution with split-type plummer blocks, mounted on robust pedestal.	
RZR 13-1120/-1600	Heavy duty casing of sheet steel with stiffening members, step welded and painted, with discharge flange. Casing is split on one axis (Size 1120), split on two axis (Sizes 1250, 1400, 1600). Heavy duty bearing execution with split-type plummer blocks, mounted on robust pedestal.	

# RZR-0200

## Technical Data

### Impeller Data

Impeller diameter	$D_r$	204 mm
Number of blades	$z$	11
Moment of Inertia	$J$	0.020 kgm <sup>2</sup>

### Impeller Data

Impeller weight	$m$	2.7 kg
Density of media	$\rho_1$	1.2 kg/m <sup>3</sup>
Tolerance class (DIN 24166)		2

### Speed limits $n_{max}$ for ATEX execution

RZR 11/12/19	<b>6513</b>	1/min
--------------	-------------	-------

## Performance Curves

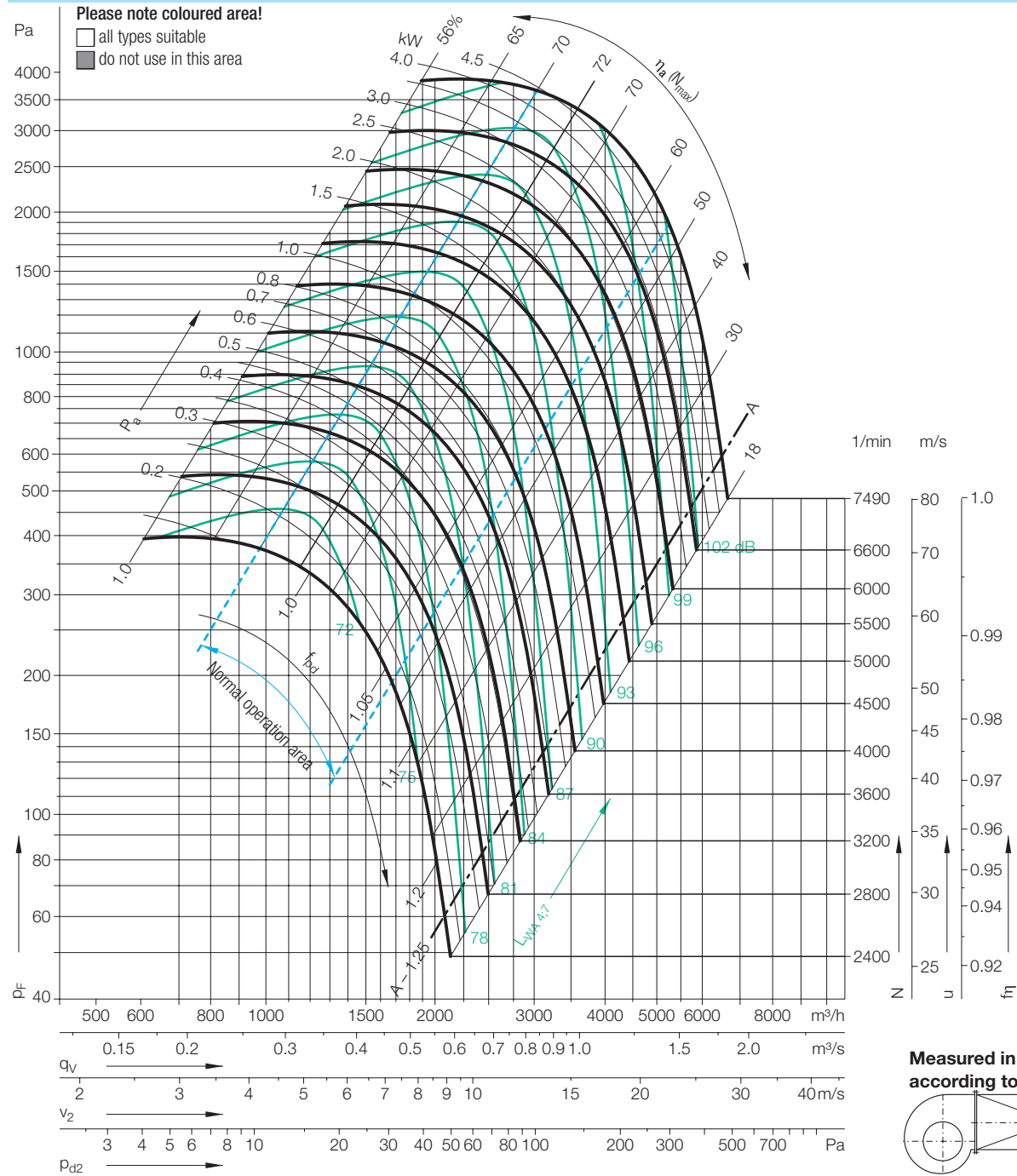

Relative sound power level for inlet side  $L_{wrel7}$  at octave centre frequencies  $f_m$

Speed	Duty point
$\leq 3745$ 1/min	$\leq 0.8 q_{Vopt}$
	$> 0.8 - 1.2 q_{Vopt}$
	$> 1.2 - 1.6 q_{Vopt}$
	$> 1.6 q_{Vopt}$
Speed	Duty point
$> 3745$ 1/min	$\leq 0.8 q_{Vopt}$
	$> 0.8 - 1.2 q_{Vopt}$
	$> 1.2 - 1.6 q_{Vopt}$
	$> 1.6 q_{Vopt}$

63	125	250	500	1000	2000	4000	8000	Hz
-4	2	0	-2	-5	-10	-14	-21	dB
-7	0	-2	-2	-5	-9	-14	-22	dB
-10	-4	-4	-2	-4	-8	-15	-24	dB
-12	-7	-6	-2	-4	-8	-13	-24	dB
63	125	250	500	1000	2000	4000	8000	Hz
-7	-1	-2	-2	-4	-10	-16	-23	dB
-12	-4	-5	-3	-4	-10	-15	-23	dB
-14	-7	-8	-4	-4	-9	-12	-21	dB
-15	-10	-11	-4	-4	-9	-12	-19	dB

Relative sound power level for discharge side  $L_{wrel4}$  at octave centre frequencies  $f_m$

63	125	250	500	1000	2000	4000	8000	Hz
11	8	3	-2	-8	-13	-19	-29	dB
7	5	1	-1	-7	-11	-18	-29	dB
5	3	-1	-1	-6	-9	-17	-20	dB
6	1	-2	-2	-6	-8	-14	-29	dB
63	125	250	500	1000	2000	4000	8000	Hz
8	7	2	-2	-6	-11	-19	-28	dB
4	3	-2	-4	-6	-8	-15	-26	dB
2	0	-4	-5	-6	-8	-13	-24	dB
4	0	-4	-6	-6	-8	-12	-21	dB



# RZR-0200

Dimensions in mm, subject to change

**RZR 11-0200** 11 kg

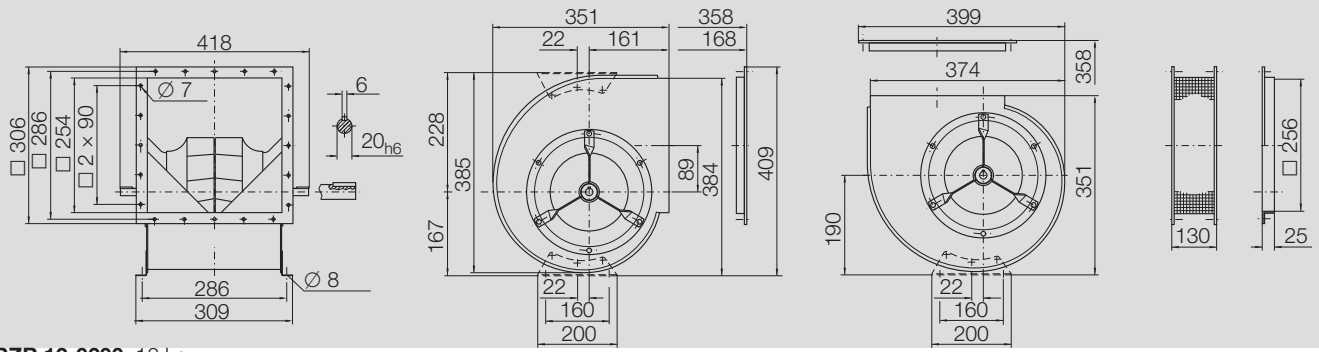

**RZR 12-0200** 12 kg

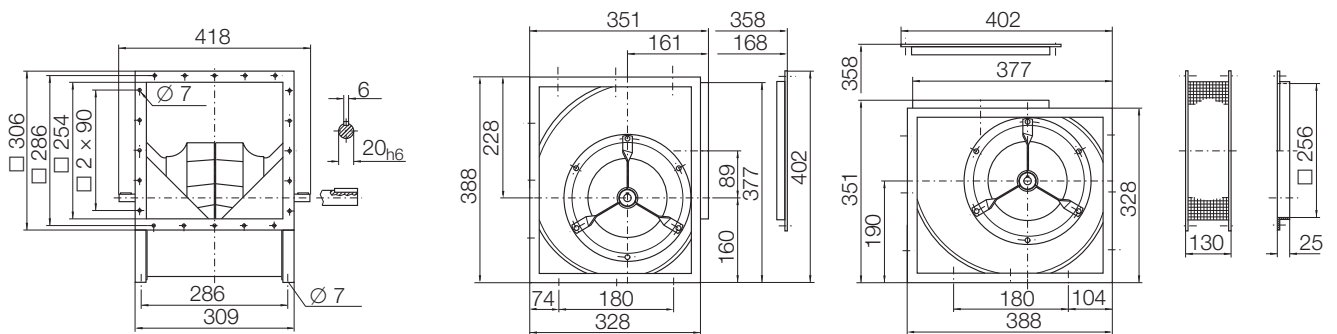

**RZR 19-0200** 13 kg

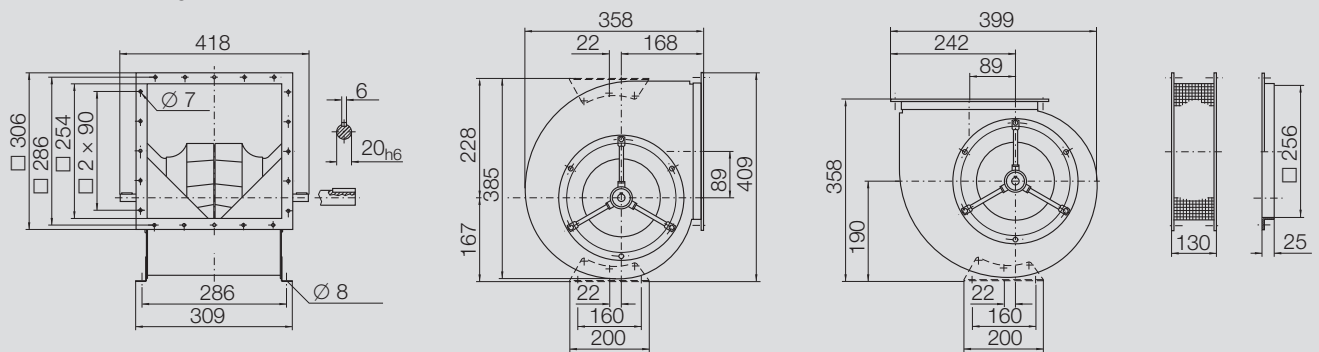

# RZR-0225

## Technical Data

### Impeller Data

Impeller diameter	$D_r$	230 mm
Number of blades	$z$	11
Moment of Inertia	$J$	0.030 kgm <sup>2</sup>

### Impeller Data

Impeller weight	$m$	3.5 kg
Density of media	$\rho_1$	1.2 kg/m <sup>3</sup>
Tolerance class (DIN 24166)		2

### Speed limits $n_{max}$ for ATEX execution

RZR 11/12/19	<b>5774</b> 1/min
--------------	-------------------

## Performance Curves

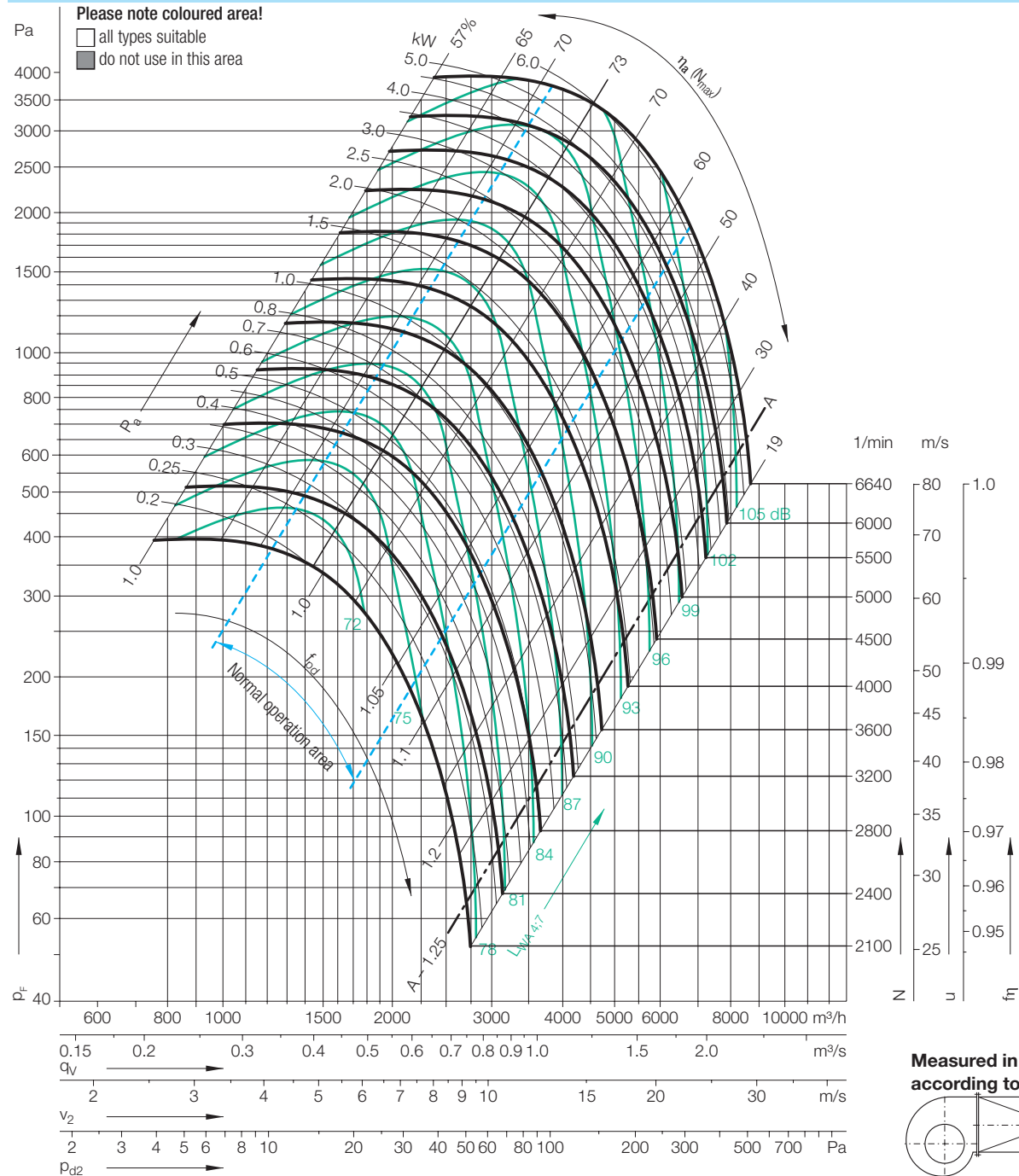

Relative sound power level for inlet side  $L_{wrel7}$  at octave centre frequencies  $f_m$

Speed	Duty point	63	125	250	500	1000	2000	4000	8000	Hz
≤3321 1/min	≤0.8 $q_{Vopt}$	-4	2	0	-2	-5	-10	-14	-21	dB
	>0.8–1.2 $q_{Vopt}$	-7	0	-2	-2	-5	-9	-14	-22	dB
	>1.2–1.6 $q_{Vopt}$	-10	-4	-4	-2	-4	-8	-15	-24	dB
	>1.6–2.0 $q_{Vopt}$	-12	-7	-6	-2	-4	-8	-13	-24	dB
	>2.0–2.5 $q_{Vopt}$	-15	-10	-11	-4	-4	-9	-12	-19	dB
>3321 1/min	≤0.8 $q_{Vopt}$	-7	-1	-2	-2	-4	-10	-16	-23	dB
	>0.8–1.2 $q_{Vopt}$	-12	-4	-5	-3	-4	-10	-15	-23	dB
	>1.2–1.6 $q_{Vopt}$	-14	-7	-8	-4	-4	-9	-12	-21	dB
	>1.6–2.0 $q_{Vopt}$	-15	-10	-11	-4	-4	-9	-12	-19	dB
	>2.0–2.5 $q_{Vopt}$	-15	-10	-11	-4	-4	-9	-12	-19	dB

Relative sound power level for discharge side  $L_{wrel4}$  at octave centre frequencies  $f_m$

Speed	Duty point	63	125	250	500	1000	2000	4000	8000	Hz
≤3321 1/min	≤0.8 $q_{Vopt}$	11	8	3	-2	-8	-13	-19	-29	dB
	>0.8–1.2 $q_{Vopt}$	7	5	1	-1	-7	-11	-18	-29	dB
	>1.2–1.6 $q_{Vopt}$	5	3	-1	-1	-6	-9	-17	-20	dB
	>1.6–2.0 $q_{Vopt}$	6	1	-2	-2	-6	-8	-14	-29	dB
	>2.0–2.5 $q_{Vopt}$	6	1	-2	-2	-6	-8	-14	-29	dB
>3321 1/min	≤0.8 $q_{Vopt}$	8	7	2	-2	-6	-11	-19	-28	dB
	>0.8–1.2 $q_{Vopt}$	4	3	-2	-4	-6	-8	-15	-26	dB
	>1.2–1.6 $q_{Vopt}$	2	0	-4	-5	-6	-8	-13	-24	dB
	>1.6–2.0 $q_{Vopt}$	4	0	-4	-6	-6	-8	-12	-21	dB
	>2.0–2.5 $q_{Vopt}$	4	0	-4	-6	-6	-8	-12	-21	dB

# RZR-0225

Dimensions in mm, subject to change

**RZR 11-0225** 13 kg

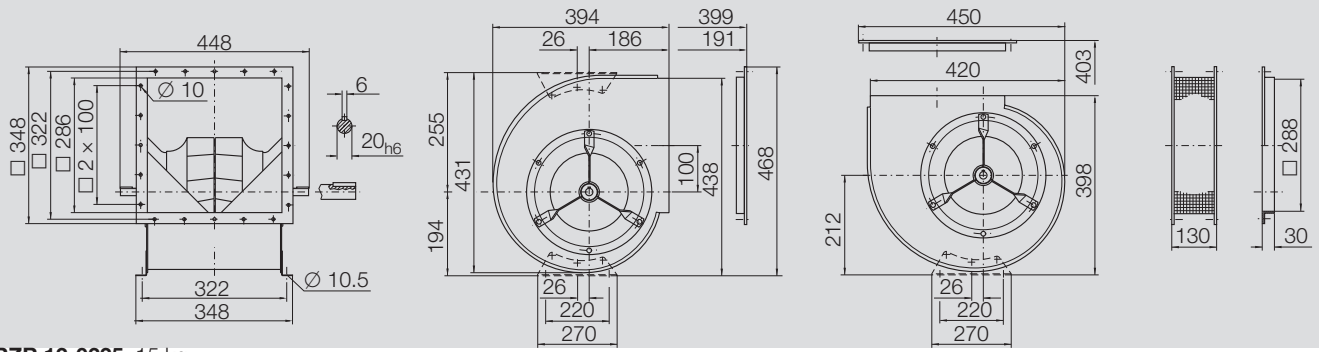

**RZR 12-0225** 15 kg

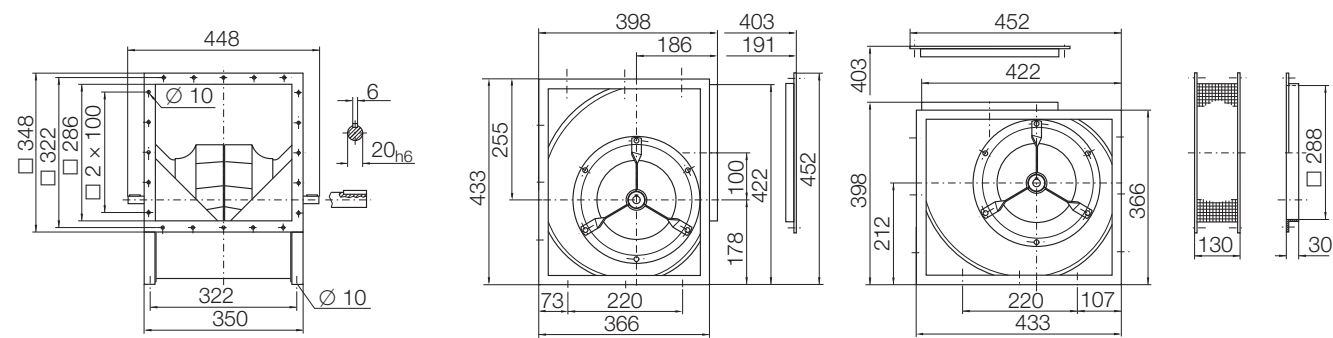

**RZR 19-0225** 16 kg

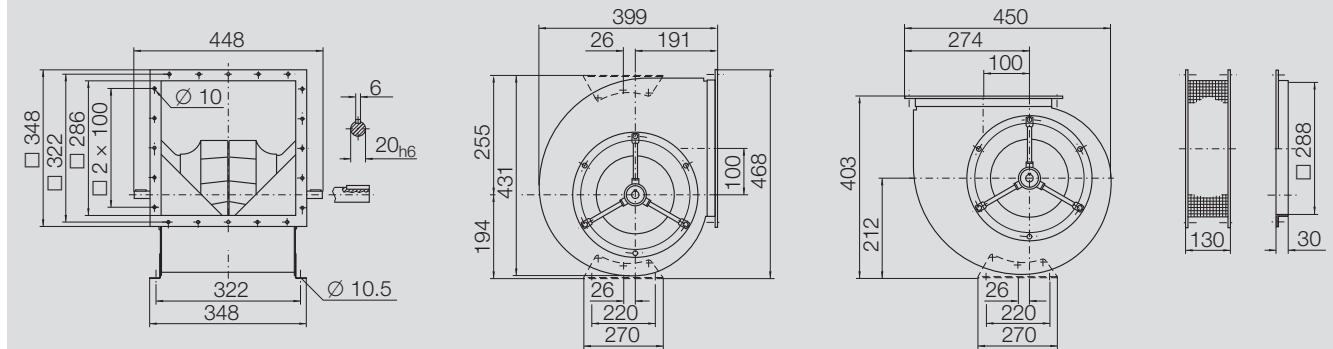



# RZR-0250

Dimensions in mm, subject to change

**RZR 11-0250** 15 kg

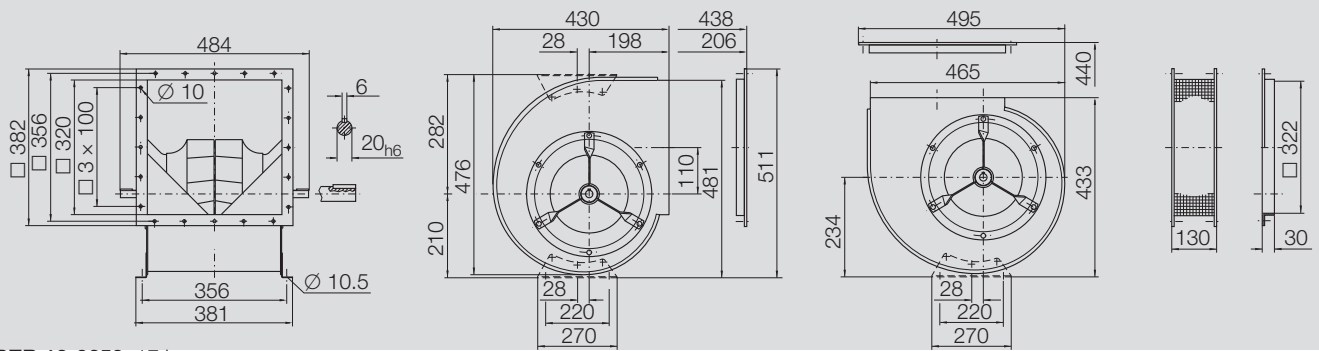

**RZR 12-0250** 17 kg

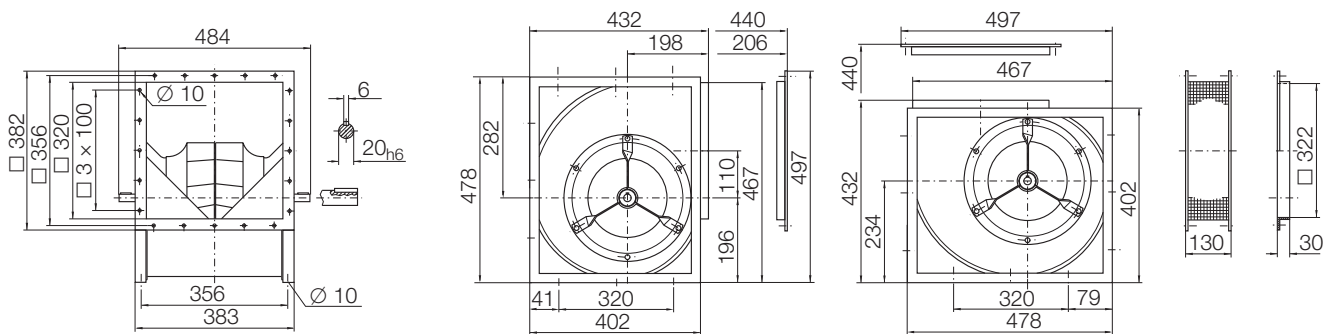

**RZR 19-0250** 17 kg

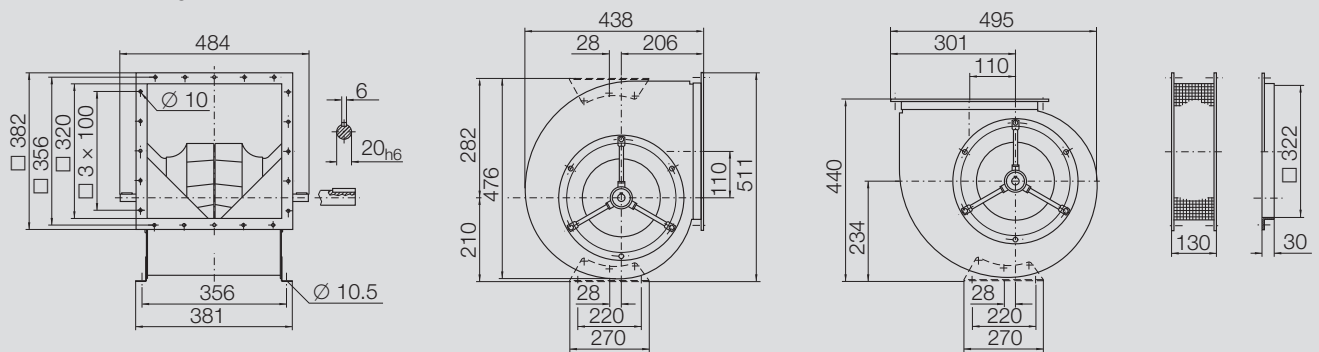

# RZR-0280

## Technical Data

### Impeller Data

Impeller diameter	$D_r$	288 mm
Number of blades	$z$	11
Moment of Inertia	$J$	0.082 kgm <sup>2</sup>

### Impeller Data

Impeller weight	$m$	5.7 kg
Density of media	$\rho_1$	1.2 kg/m <sup>3</sup>
Tolerance class (DIN 24166)		2

### Speed limits $n_{max}$ for ATEX execution

RZR 11/12/19	4582 1/min
--------------	------------

## Performance Curves

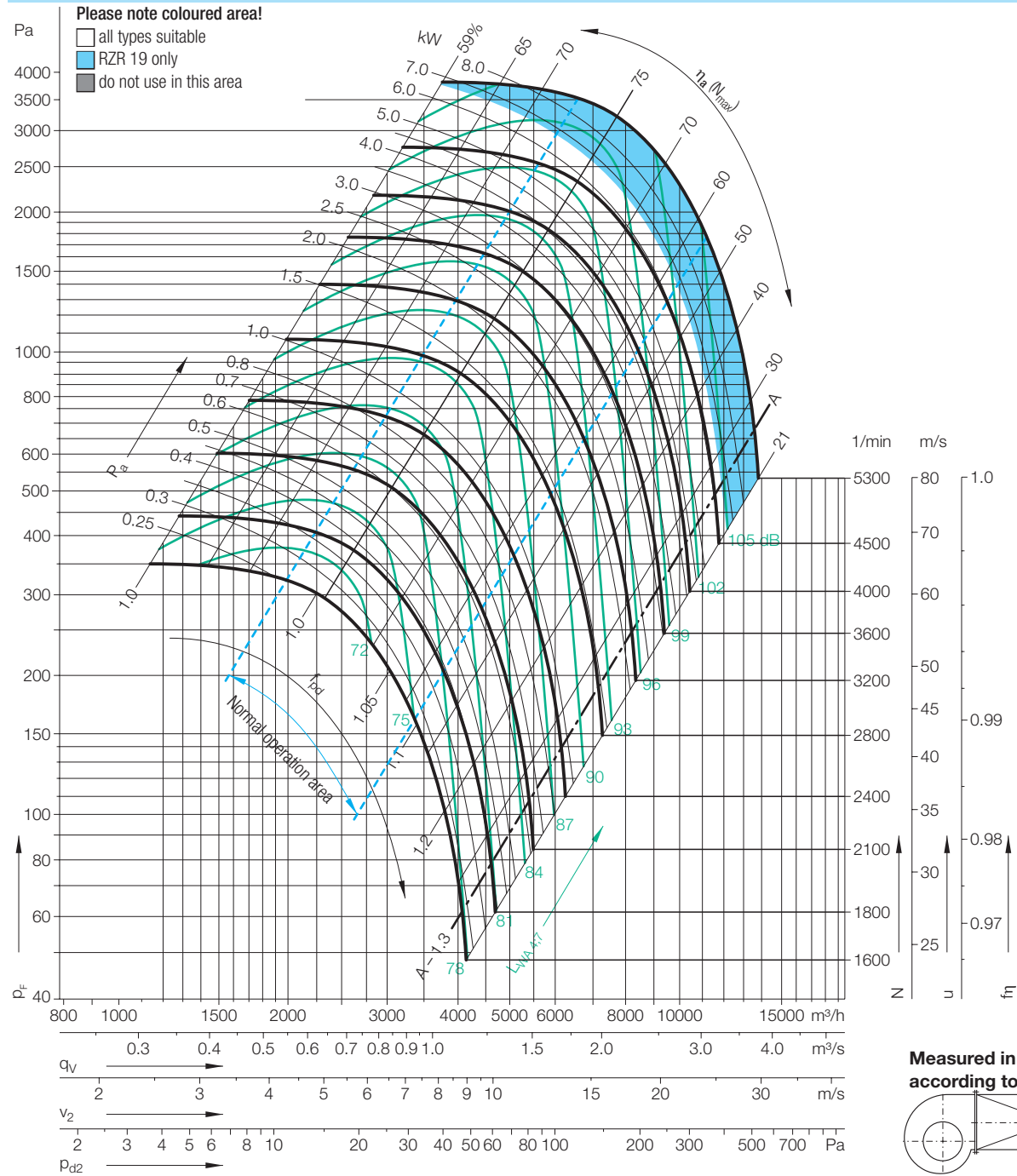

Measured in installation B according to ISO 5801:

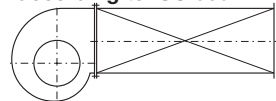

Relative sound power level for inlet side  $L_{Wrel7}$  at octave centre frequencies  $f_m$

Speed	Duty point	63	125	250	500	1000	2000	4000	8000	Hz
$\leq 2653$ 1/min	$\leq 0.8 q_{Vopt}$	-4	2	0	-2	-5	-10	-14	-21	dB
	$> 0.8 - 1.2 q_{Vopt}$	-7	0	-2	-2	-5	-9	-14	-22	dB
	$> 1.2 - 1.6 q_{Vopt}$	-10	-4	-4	-2	-4	-8	-15	-24	dB
	$> 1.6 - 2.0 q_{Vopt}$	-12	-7	-6	-2	-4	-8	-13	-24	dB
	$> 2.0 q_{Vopt}$	-15	-10	-11	-4	-4	-9	-12	-19	dB
$> 2653$ 1/min	$\leq 0.8 q_{Vopt}$	-7	-1	-2	-2	-4	-10	-16	-23	dB
	$> 0.8 - 1.2 q_{Vopt}$	-12	-4	-5	-3	-4	-10	-15	-23	dB
	$> 1.2 - 1.6 q_{Vopt}$	-14	-7	-8	-4	-4	-9	-12	-21	dB
	$> 1.6 - 2.0 q_{Vopt}$	-15	-10	-11	-4	-4	-9	-12	-19	dB
	$> 2.0 q_{Vopt}$	-15	-10	-11	-4	-4	-9	-12	-19	dB

Relative sound power level for discharge side  $L_{Wrel4}$  at octave centre frequencies  $f_m$

Speed	Duty point	63	125	250	500	1000	2000	4000	8000	Hz
$\leq 2653$ 1/min	$\leq 0.8 q_{Vopt}$	11	8	3	-2	-8	-13	-19	-29	dB
	$> 0.8 - 1.2 q_{Vopt}$	7	5	1	-1	-7	-11	-18	-29	dB
	$> 1.2 - 1.6 q_{Vopt}$	5	3	-1	-1	-6	-9	-17	-20	dB
	$> 1.6 - 2.0 q_{Vopt}$	6	1	-2	-2	-6	-8	-14	-29	dB
	$> 2.0 q_{Vopt}$	6	1	-2	-2	-6	-8	-14	-29	dB
$> 2653$ 1/min	$\leq 0.8 q_{Vopt}$	8	7	2	-2	-6	-11	-19	-28	dB
	$> 0.8 - 1.2 q_{Vopt}$	4	3	-2	-4	-6	-8	-15	-26	dB
	$> 1.2 - 1.6 q_{Vopt}$	2	0	-4	-5	-6	-8	-13	-24	dB
	$> 1.6 - 2.0 q_{Vopt}$	4	0	-4	-6	-6	-8	-12	-21	dB
	$> 2.0 q_{Vopt}$	4	0	-4	-6	-6	-8	-12	-21	dB

# RZR-0280

Dimensions in mm, subject to change

**RZR 11-0280** 20 kg

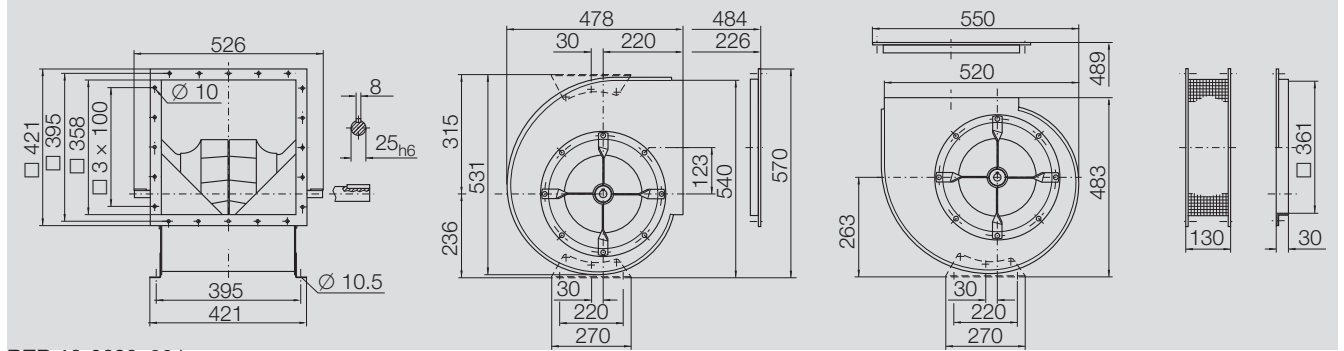

**RZR 12-0280** 23 kg

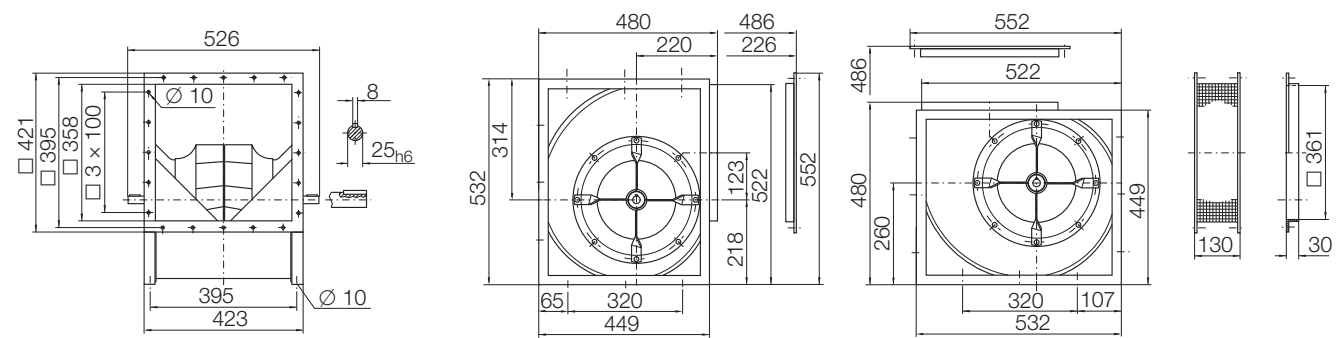

**RZR 19-0280** 23 kg

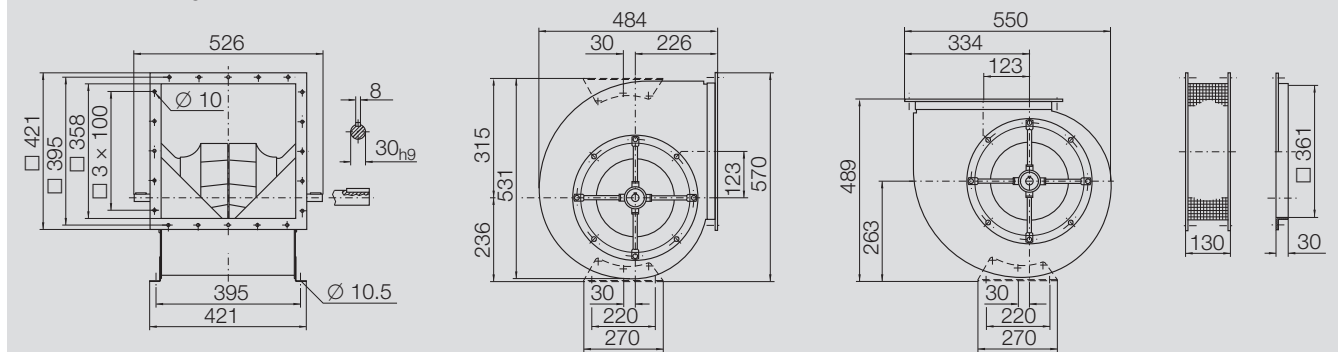

# RZR-0315

## Technical Data

### Impeller Data

Impeller diameter	$D_r$	323 mm
Number of blades	$z$	12
Moment of Inertia	$J$	0.126 kgm <sup>2</sup>

### Impeller Data

Impeller weight	$m$	7.1 kg
Density of media	$\rho_1$	1.2 kg/m <sup>3</sup>
Tolerance class (DIN 24166)		1

### Speed limits $n_{max}$ for ATEX execution

RZR 11/12	<b>3793</b>	1/min
RZR 19	<b>4113</b>	1/min

## Performance Curves

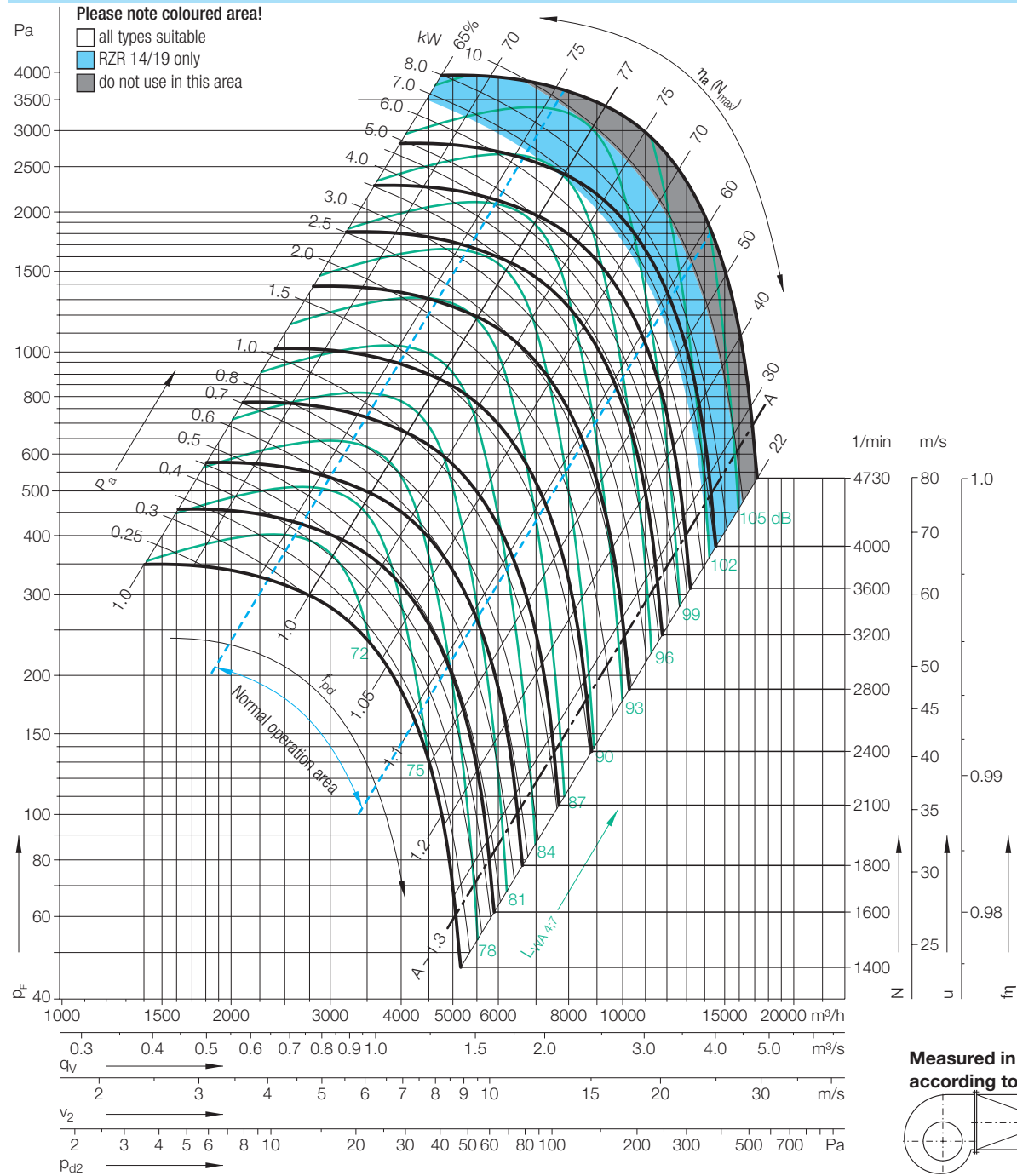

Relative sound power level for inlet side  $L_{wrel7}$  at octave centre frequencies  $f_m$

63	125	250	500	1000	2000	4000	8000	Hz
0	2	0	-3	-6	-9	-12	-19	dB
-2	1	-2	-3	-6	-8	-14	-20	dB
-3	0	-1	-3	-6	-8	-14	-21	dB
-5	-3	-3	-3	-6	-7	-13	-21	dB
63	125	250	500	1000	2000	4000	8000	Hz
-2	-1	-3	-1	-6	-10	-15	-21	dB
-7	-4	-5	-1	-6	-9	-14	-21	dB
-10	-7	-8	-1	-5	-8	-13	-21	dB
-10	-8	-8	-2	-6	-8	-11	-18	dB

Relative sound power level for discharge side  $L_{wrel4}$  at octave centre frequencies  $f_m$

63	125	250	500	1000	2000	4000	8000	Hz
13	7	4	-3	-8	-14	-17	-25	dB
10	5	3	-2	-7	-13	-17	-25	dB
7	2	2	-2	-6	-12	-18	-27	dB
5	1	1	-2	-6	-10	-17	-27	dB
63	125	250	500	1000	2000	4000	8000	Hz
11	4	2	0	-7	-12	-17	-24	dB
7	1	-2	-3	-6	-10	-15	-23	dB
3	-2	-4	-3	-5	-9	-14	-23	dB
2	-3	-5	-3	-5	-9	-12	-21	dB



# RZR-0315

Dimensions in mm, subject to change

**RZR 11-0315** 24 kg

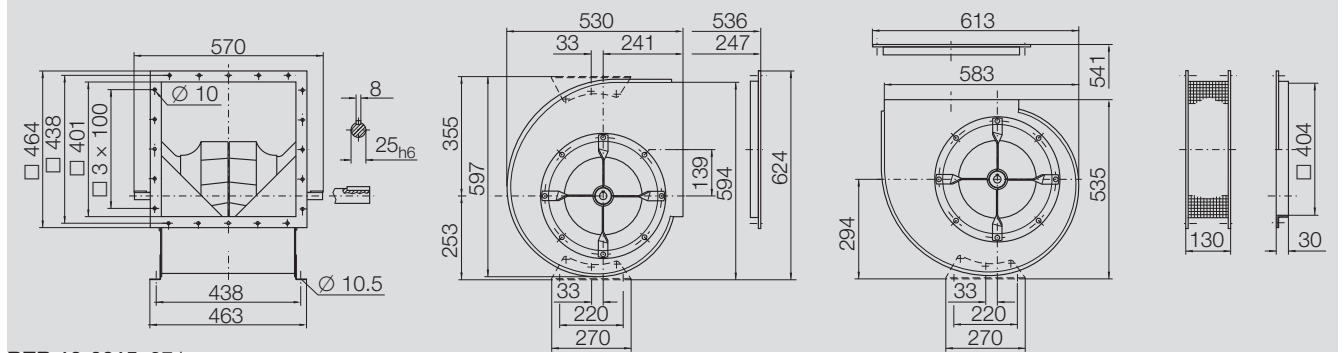

**RZR 12-0315** 27 kg

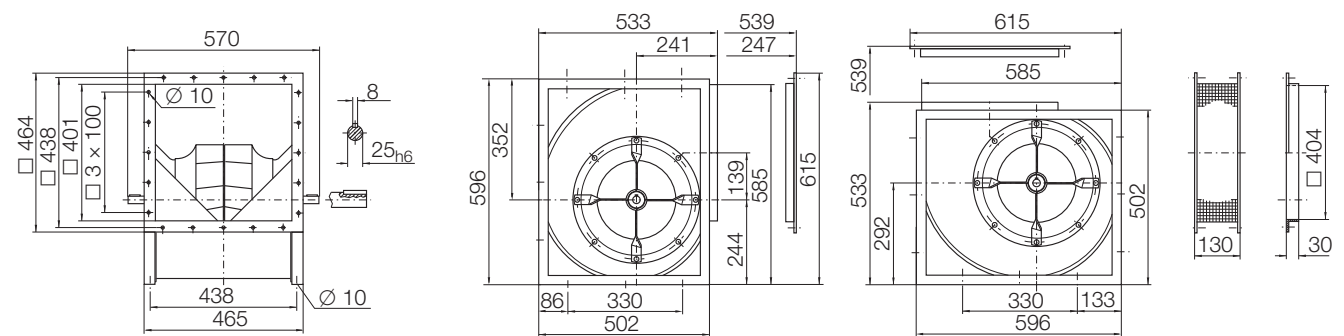

**RZR 14-0315** 35 kg

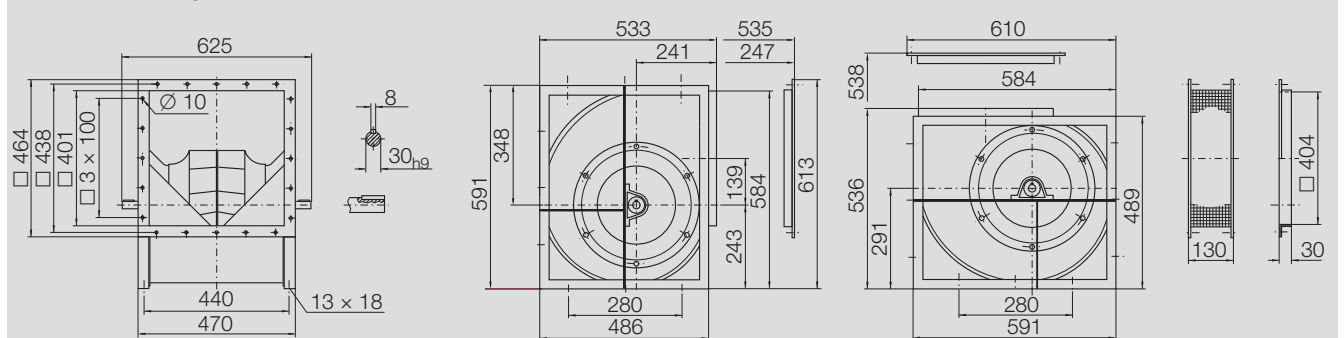

**RZR 19-0315** 28 kg

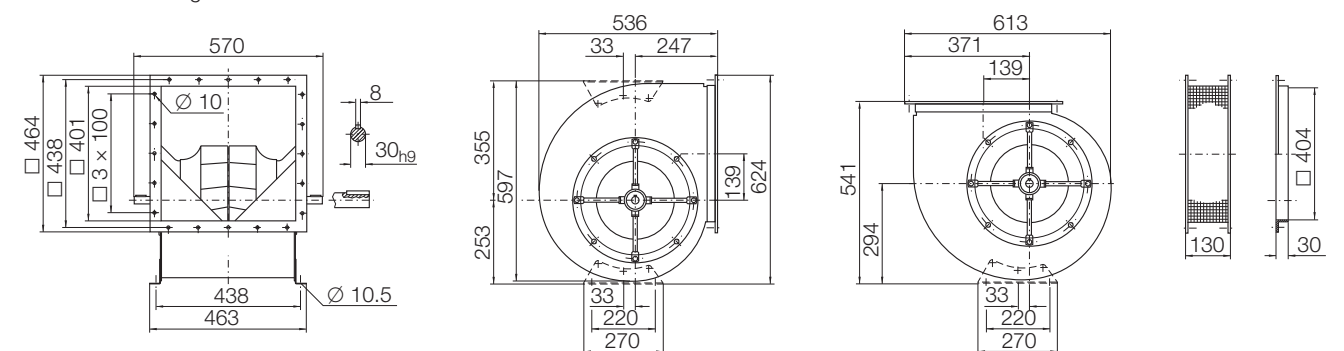

# RZR-0355

Performance certified is for installation type B - free inlet, ducted outlet.  
 Power rating (kW) does not include transmission losses.  
 Performance ratings do not include the effects of appurtenances (accessories).

## Technical Data

### Impeller Data

Impeller diameter	$D_r$	363 mm
Number of blades	$z$	12
Moment of Inertia	$J$	0.220 kgm <sup>2</sup>

### Impeller Data

Impeller weight	$m$	9.1 kg
Density of media	$\rho_1$	1.2 kg/m <sup>3</sup>
Tolerance class (DIN 24166)		1

### Speed limits $n_{max}$ for ATEX execution

RZR 11/12	<b>3110</b>	1/min
RZR 19	<b>3555</b>	1/min

## Performance Curves

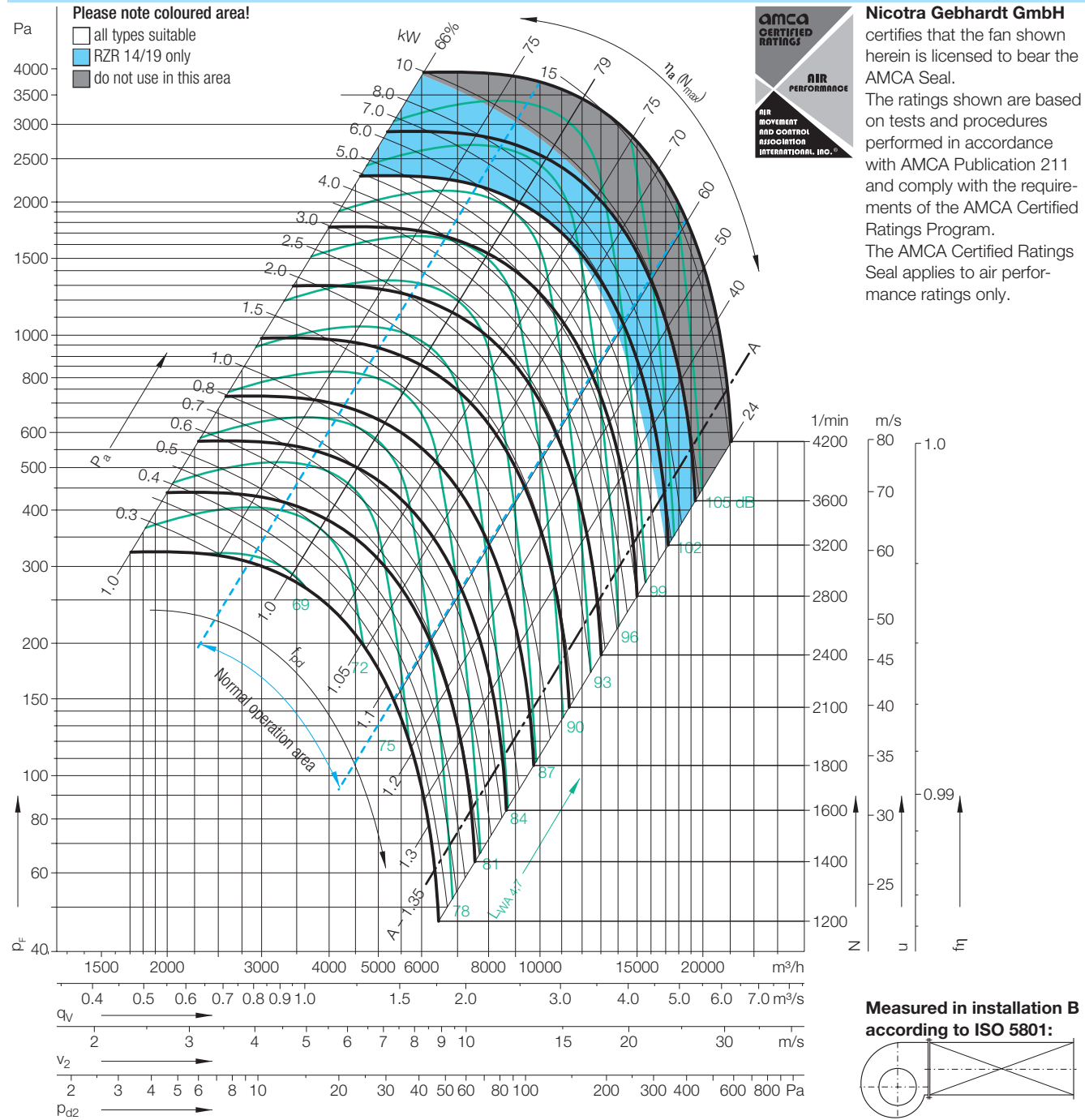

**Nicotra Gebhardt GmbH** certifies that the fan shown herein is licensed to bear the AMCA Seal. The ratings shown are based on tests and procedures performed in accordance with AMCA Publication 211 and comply with the requirements of the AMCA Certified Ratings Program. The AMCA Certified Ratings Seal applies to air performance ratings only.

Relative sound power level for inlet side  $L_{Wrel7}$  at octave centre frequencies  $f_m$

Speed	Duty point	63	125	250	500	1000	2000	4000	8000	Hz
$\leq 2105$ 1/min	$\leq 0.8 q_{Vopt}$	0	2	0	-3	-6	-9	-12	-19	dB
	$> 0.8 - 1.2 q_{Vopt}$	-2	1	-2	-3	-6	-8	-14	-20	dB
	$> 1.2 - 1.6 q_{Vopt}$	-3	0	-1	-3	-6	-8	-14	-21	dB
	$> 1.6 - 2.0 q_{Vopt}$	-5	-3	-3	-3	-6	-7	-13	-21	dB
	$> 2.0 q_{Vopt}$	-5	-3	-3	-3	-6	-7	-13	-21	dB
$> 2105$ 1/min	$\leq 0.8 q_{Vopt}$	-2	-1	-3	-1	-6	-10	-15	-21	dB
	$> 0.8 - 1.2 q_{Vopt}$	-7	-4	-5	-1	-6	-9	-14	-21	dB
	$> 1.2 - 1.6 q_{Vopt}$	-10	-7	-8	-1	-5	-8	-13	-21	dB
	$> 1.6 - 2.0 q_{Vopt}$	-10	-8	-8	-2	-6	-8	-11	-18	dB
	$> 2.0 q_{Vopt}$	-10	-8	-8	-2	-6	-8	-11	-18	dB

Relative sound power level for discharge side  $L_{Wrel4}$  at octave centre frequencies  $f_m$

Speed	Duty point	63	125	250	500	1000	2000	4000	8000	Hz
$\leq 2105$ 1/min	$\leq 0.8 q_{Vopt}$	13	7	4	-3	-8	-14	-17	-25	dB
	$> 0.8 - 1.2 q_{Vopt}$	10	5	3	-2	-7	-13	-17	-25	dB
	$> 1.2 - 1.6 q_{Vopt}$	7	2	2	-2	-6	-12	-18	-27	dB
	$> 1.6 - 2.0 q_{Vopt}$	5	1	1	-2	-6	-10	-17	-27	dB
	$> 2.0 q_{Vopt}$	5	1	1	-2	-6	-10	-17	-27	dB
$> 2105$ 1/min	$\leq 0.8 q_{Vopt}$	11	4	2	0	-7	-12	-17	-24	dB
	$> 0.8 - 1.2 q_{Vopt}$	7	1	-2	-3	-6	-10	-15	-23	dB
	$> 1.2 - 1.6 q_{Vopt}$	3	-2	-4	-3	-5	-9	-14	-23	dB
	$> 1.6 - 2.0 q_{Vopt}$	2	-3	-5	-3	-5	-9	-12	-21	dB
	$> 2.0 q_{Vopt}$	2	-3	-5	-3	-5	-9	-12	-21	dB

# RZR-0355

Dimensions in mm, subject to change

**RZR 11-0355** 33 kg

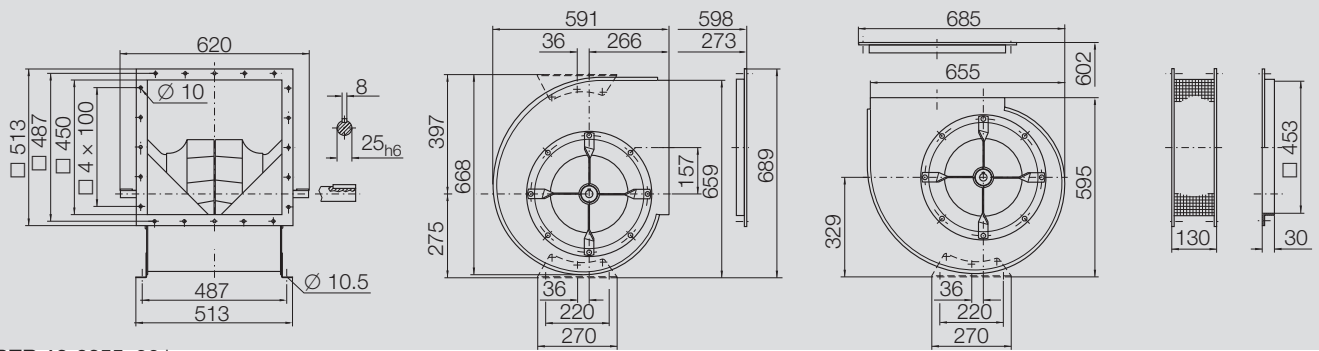

**RZR 12-0355** 36 kg

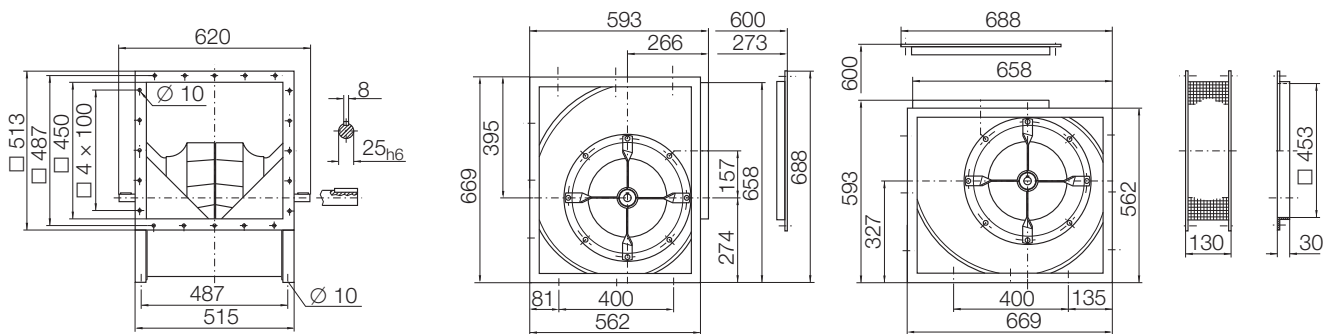

**RZR 14-0355** 50 kg

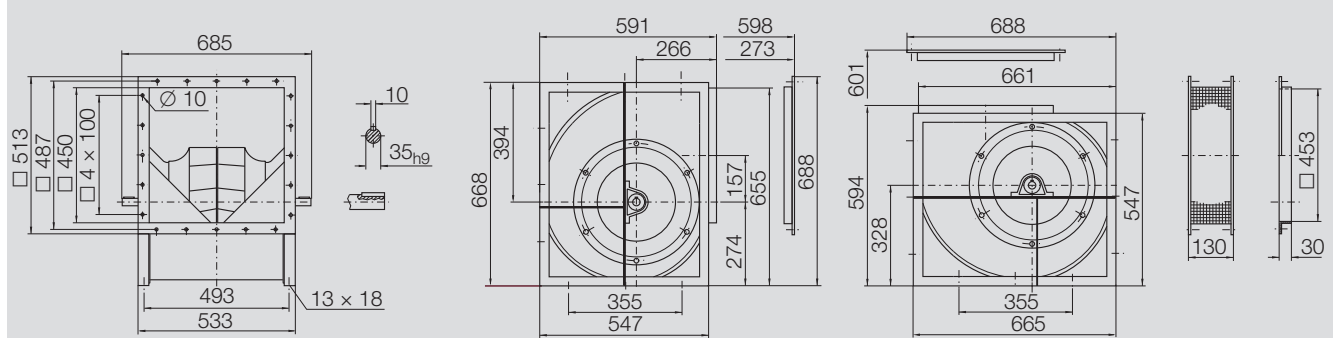

**RZR 19-0355** 39 kg

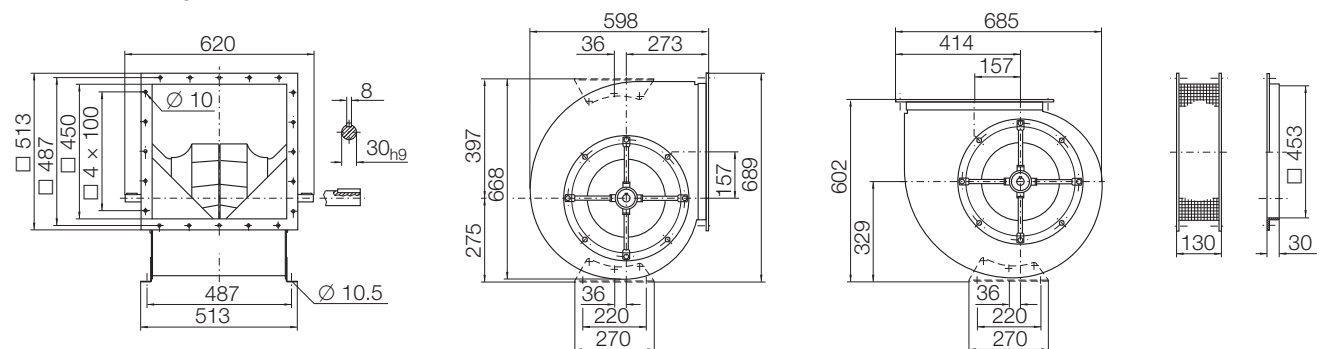

# RZR-0400

Performance certified is for installation type B - free inlet, ducted outlet.  
 Power rating (kW) does not include transmission losses.  
 Performance ratings do not include the effects of appurtenances (accessories).

## Technical Data

### Impeller Data

Impeller diameter	$D_r$	406 mm
Number of blades	$z$	12
Moment of Inertia	$J$	0.33 kgm <sup>2</sup>

### Impeller Data

Impeller weight	$m$	10.5 kg
Density of media	$\rho_1$	1.2 kg/m <sup>3</sup>
Tolerance class (DIN 24166)		1

### Speed limits $n_{max}$ for ATEX execution

RZR 11/12	<b>2552</b>	1/min
RZR 18	<b>2913</b>	1/min
RZR 13	<b>3145</b>	1/min

## Performance Curves

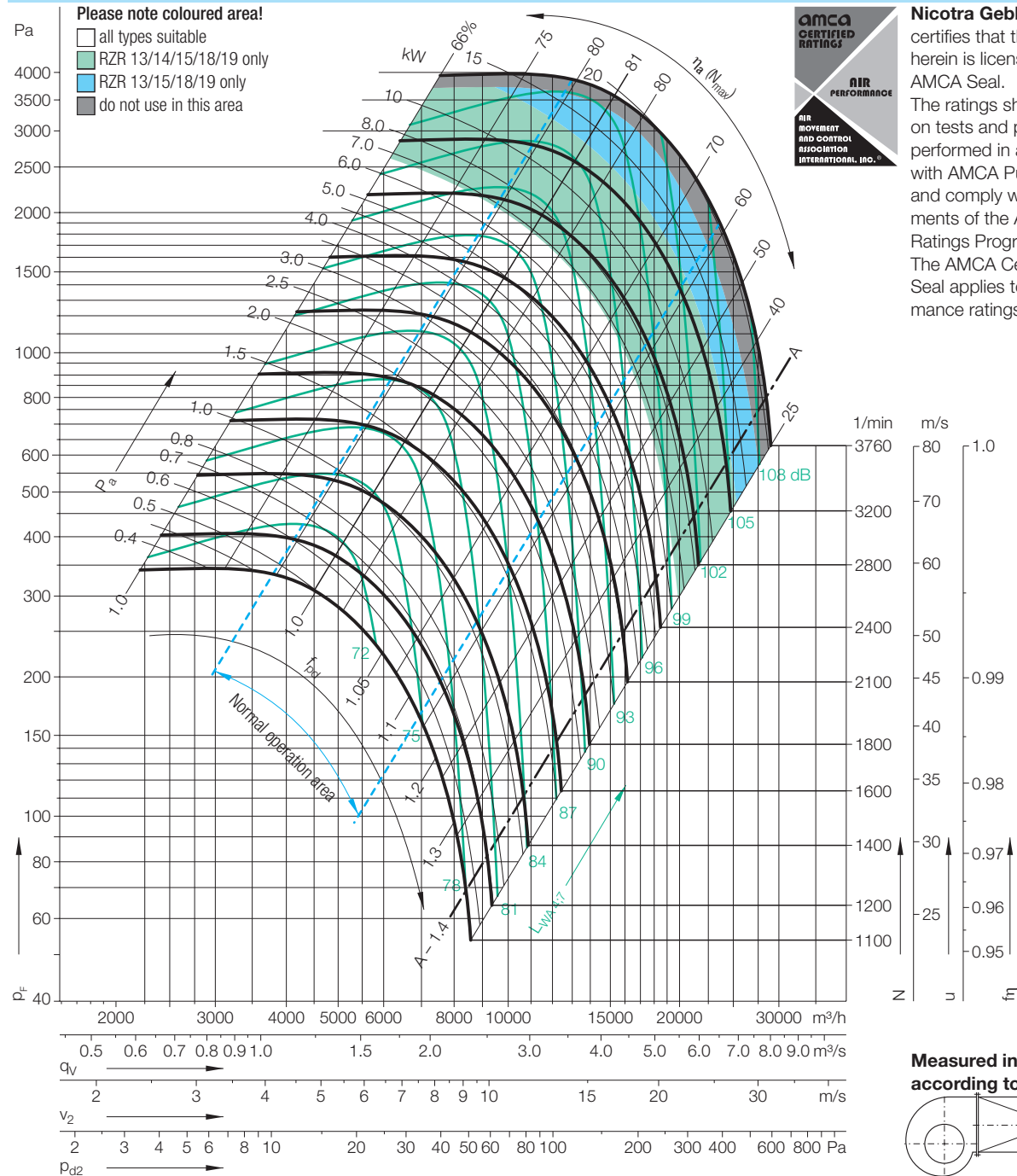

**Nicotra Gebhardt GmbH** certifies that the fan shown herein is licensed to bear the AMCA Seal. The ratings shown are based on tests and procedures performed in accordance with AMCA Publication 211 and comply with the requirements of the AMCA Certified Ratings Program. The AMCA Certified Ratings Seal applies to air performance ratings only.



Relative sound power level for inlet side  $L_{wrel7}$  at octave centre frequencies  $f_m$

Speed	Duty point	63	125	250	500	1000	2000	4000	8000	Hz
≤1882 1/min	≤0.8 $q_{Vopt}$	0	2	0	-3	-6	-9	-12	-19	dB
	>0.8–1.2 $q_{Vopt}$	-2	1	-2	-3	-6	-8	-14	-20	dB
	>1.2–1.6 $q_{Vopt}$	-3	0	-1	-3	-6	-8	-14	-21	dB
	>1.6–2.0 $q_{Vopt}$	-5	-3	-3	-3	-6	-7	-13	-21	dB
	>2.0 $q_{Vopt}$	-5	-3	-3	-3	-6	-7	-13	-21	dB
>1882 1/min	≤0.8 $q_{Vopt}$	-2	-1	-3	-1	-6	-10	-15	-21	dB
	>0.8–1.2 $q_{Vopt}$	-7	-4	-5	-1	-6	-9	-14	-21	dB
	>1.2–1.6 $q_{Vopt}$	-10	-7	-8	-1	-5	-8	-13	-21	dB
	>1.6–2.0 $q_{Vopt}$	-10	-8	-8	-2	-6	-8	-11	-18	dB
	>2.0 $q_{Vopt}$	-10	-8	-8	-2	-6	-8	-11	-18	dB

Relative sound power level for discharge side  $L_{wrel4}$  at octave centre frequencies  $f_m$

Speed	Duty point	63	125	250	500	1000	2000	4000	8000	Hz
≤1882 1/min	≤0.8 $q_{Vopt}$	13	7	4	-3	-8	-14	-17	-25	dB
	>0.8–1.2 $q_{Vopt}$	10	5	3	-2	-7	-13	-17	-25	dB
	>1.2–1.6 $q_{Vopt}$	7	2	2	-2	-6	-12	-18	-27	dB
	>1.6–2.0 $q_{Vopt}$	5	1	1	-2	-6	-10	-17	-27	dB
	>2.0 $q_{Vopt}$	5	1	1	-2	-6	-10	-17	-27	dB
>1882 1/min	≤0.8 $q_{Vopt}$	11	4	2	0	-7	-12	-17	-24	dB
	>0.8–1.2 $q_{Vopt}$	7	1	-2	-3	-6	-10	-15	-23	dB
	>1.2–1.6 $q_{Vopt}$	3	-2	-4	-3	-5	-9	-14	-23	dB
	>1.6–2.0 $q_{Vopt}$	2	-3	-5	-3	-5	-9	-12	-21	dB
	>2.0 $q_{Vopt}$	2	-3	-5	-3	-5	-9	-12	-21	dB

# RZR-0400

Dimensions in mm, subject to change

**RZR 11-0400** 43 kg

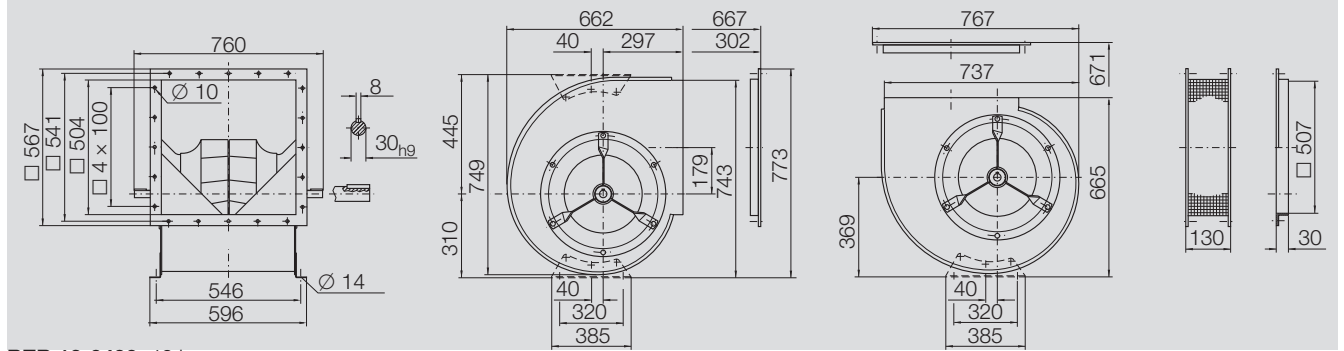

**RZR 12-0400** 49 kg

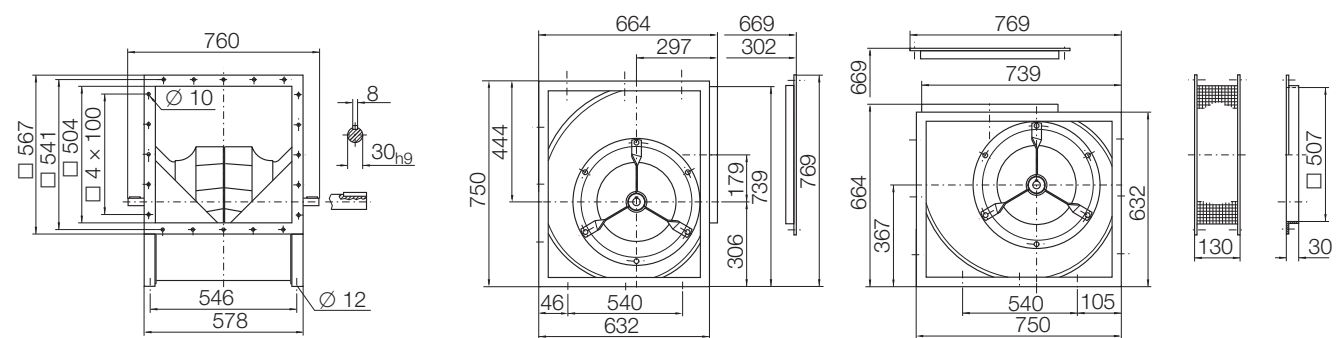

**RZR 14-0400** 56 kg

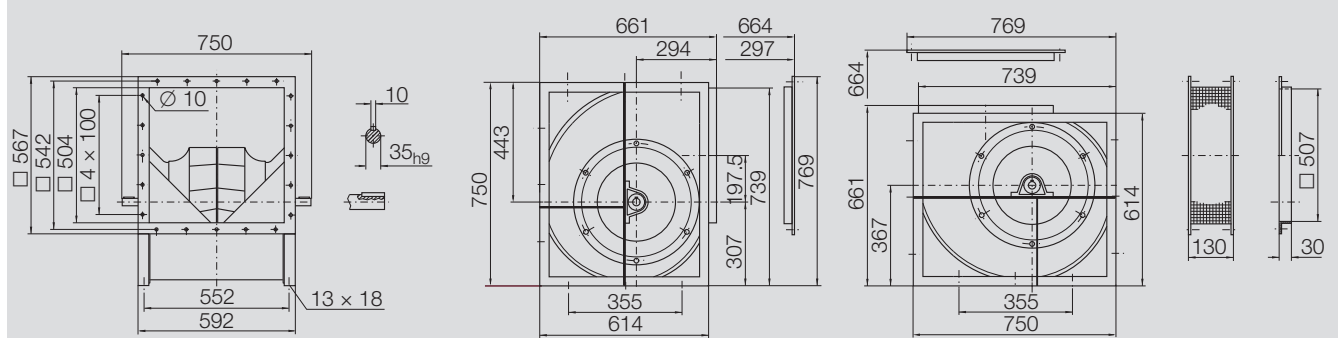

**RZR 15-0400** 61 kg **RZR 19-0400** 66 kg

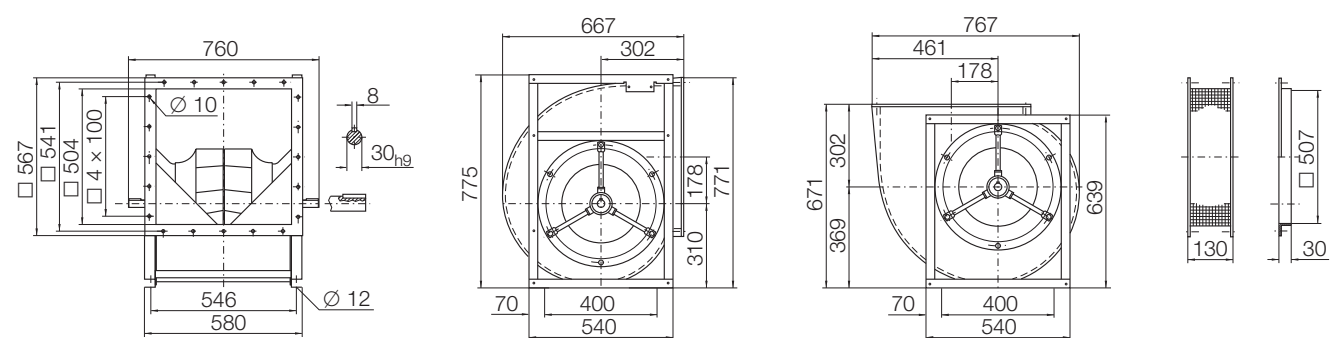

**RZR 18-0400** 70 kg **RZR 13-0400** 75 kg

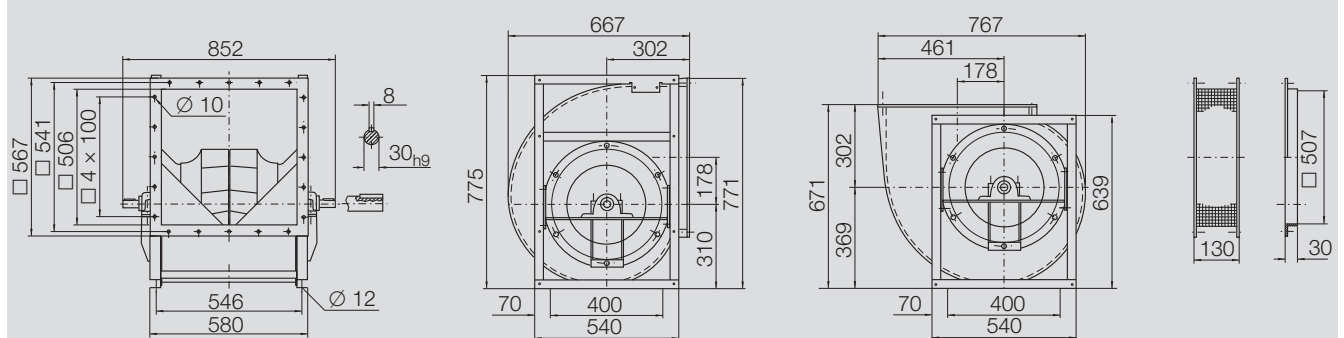

# RZR-0450

Performance certified is for installation type B - free inlet, ducted outlet.  
 Power rating (kW) does not include transmission losses.  
 Performance ratings do not include the effects of appurtenances (accessories).

## Technical Data

### Impeller Data

Impeller diameter	$D_r$	455 mm
Number of blades	$z$	12
Moment of Inertia	$J$	0.6 kgm <sup>2</sup>

### Impeller Data

Impeller weight	$m$	15.8 kg
Density of media	$\rho_1$	1.2 kg/m <sup>3</sup>
Tolerance class (DIN 24166)		1

### Speed limits $n_{max}$ for ATEX execution

RZR 11/12	<b>2111</b>	1/min
RZR 18	<b>2410</b>	1/min
RZR 13	<b>2922</b>	1/min

## Performance Curves

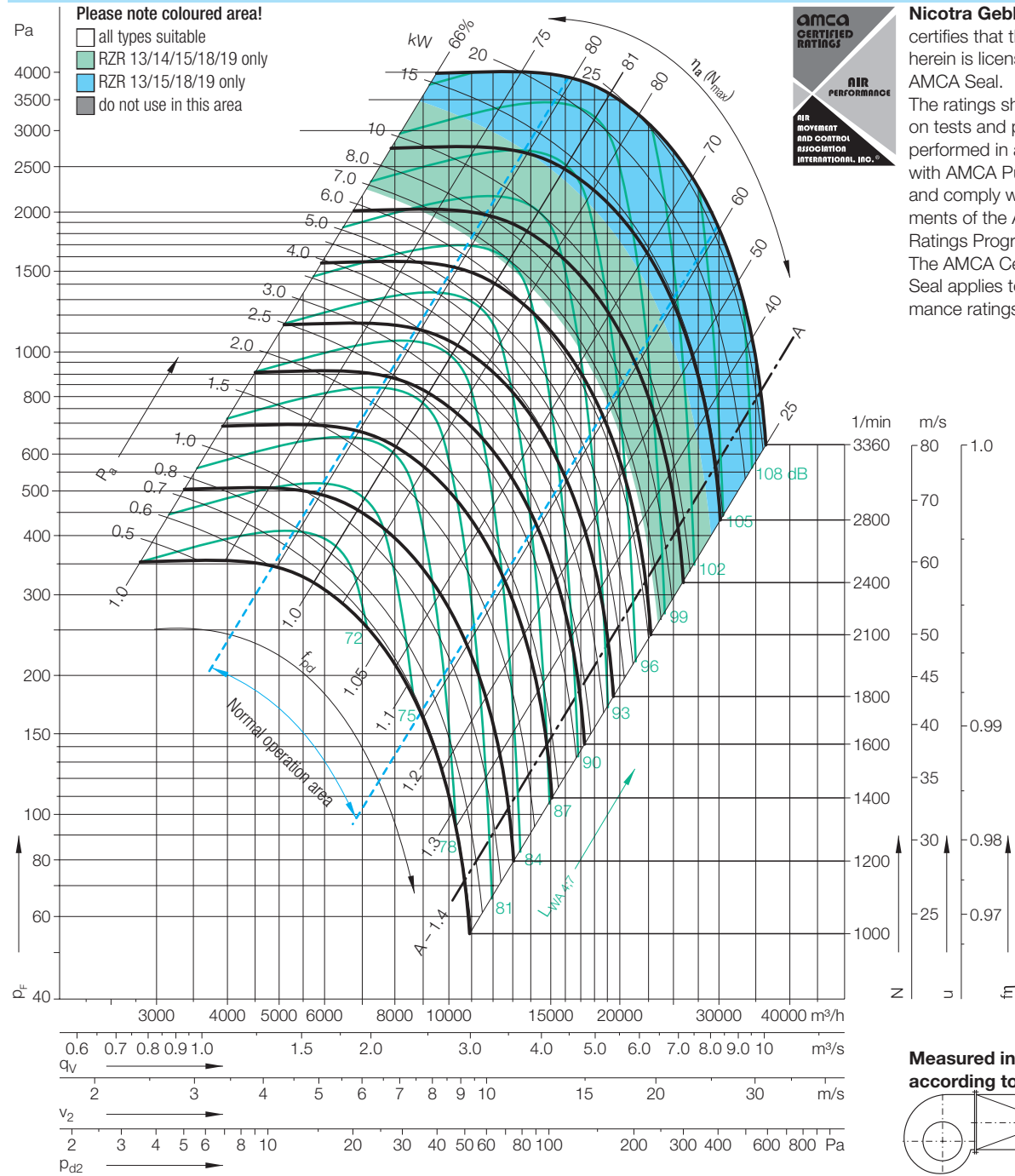

**Nicotra Gebhardt GmbH** certifies that the fan shown herein is licensed to bear the AMCA Seal. The ratings shown are based on tests and procedures performed in accordance with AMCA Publication 211 and comply with the requirements of the AMCA Certified Ratings Program. The AMCA Certified Ratings Seal applies to air performance ratings only.

Speed	Duty point
≤1679 1/min	≤0.8 $q_{Vopt}$
	>0.8–1.2 $q_{Vopt}$
	>1.2–1.6 $q_{Vopt}$
	>1.6 $q_{Vopt}$
Speed	Duty point
>1679 1/min	≤0.8 $q_{Vopt}$
	>0.8–1.2 $q_{Vopt}$
	>1.2–1.6 $q_{Vopt}$
	>1.6 $q_{Vopt}$

Relative sound power level for inlet side  $L_{Wrel7}$  at octave centre frequencies  $f_m$

63	125	250	500	1000	2000	4000	8000	Hz
0	2	0	-3	-6	-9	-12	-19	dB
-2	1	-2	-3	-6	-8	-14	-20	dB
-3	0	-1	-3	-6	-8	-14	-21	dB
-5	-3	-3	-3	-6	-7	-13	-21	dB
63	125	250	500	1000	2000	4000	8000	Hz
-2	-1	-3	-1	-6	-10	-15	-21	dB
-7	-4	-5	-1	-6	-9	-14	-21	dB
-10	-7	-8	-1	-5	-8	-13	-21	dB
-10	-8	-8	-2	-6	-8	-11	-18	dB

Relative sound power level for discharge side  $L_{Wrel4}$  at octave centre frequencies  $f_m$

63	125	250	500	1000	2000	4000	8000	Hz
13	7	4	-3	-8	-14	-17	-25	dB
10	5	3	-2	-7	-13	-17	-25	dB
7	2	2	-2	-6	-12	-18	-27	dB
5	1	1	-2	-6	-10	-17	-27	dB
63	125	250	500	1000	2000	4000	8000	Hz
11	4	2	0	-7	-12	-17	-24	dB
7	1	-2	-3	-6	-10	-15	-23	dB
3	-2	-4	-3	-5	-9	-14	-23	dB
2	-3	-5	-3	-5	-9	-12	-21	dB

# RZR-0450

Dimensions in mm, subject to change

**RZR 11-0450** 54 kg

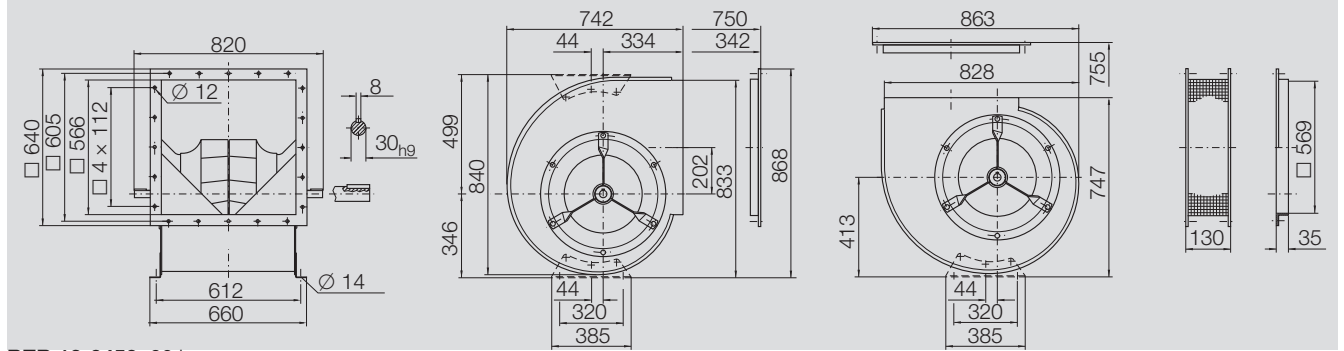

**RZR 12-0450** 60 kg

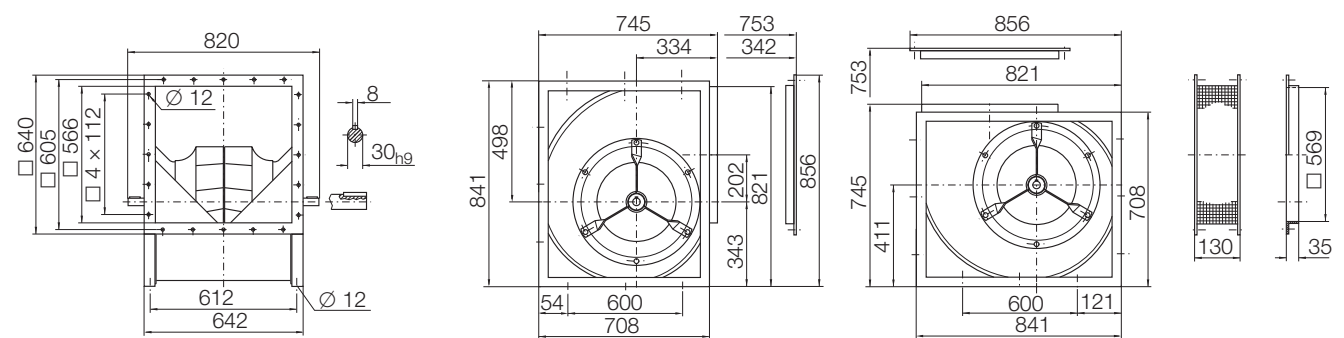

**RZR 14-0450** 82 kg

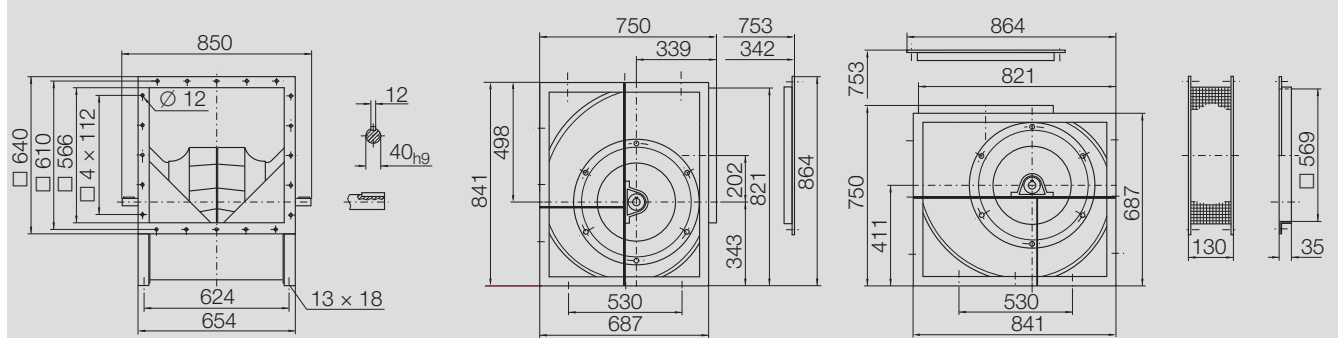

**RZR 15-0450** 73 kg **RZR 19-0450** 82 kg

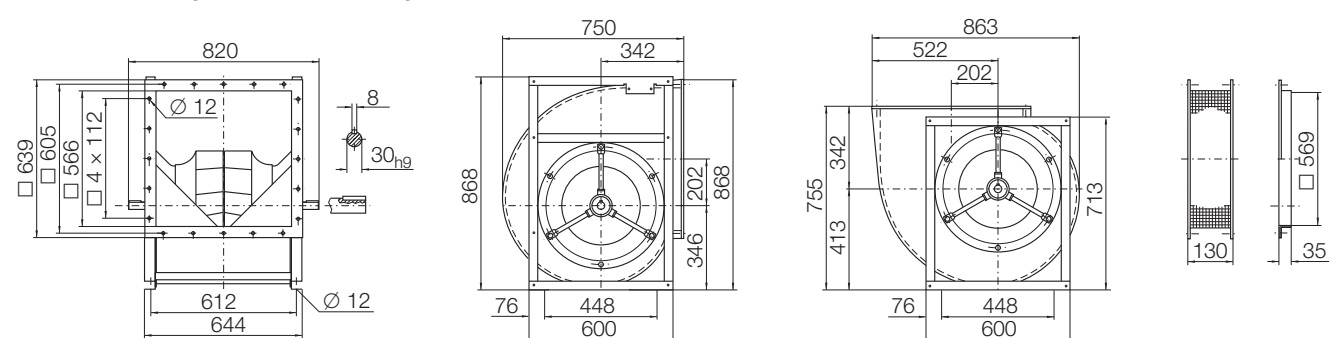

**RZR 18-0450** 83 kg **RZR 13-0450** 92 kg

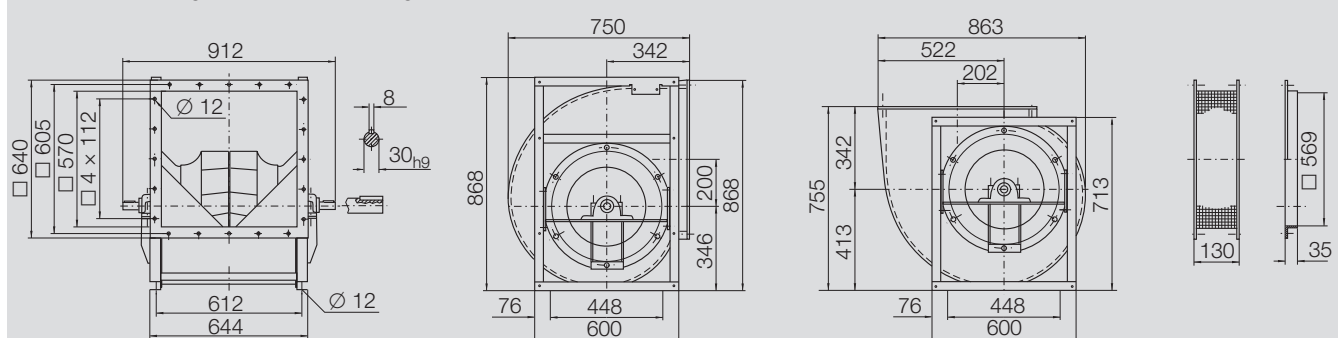

# RZR-0500

Performance certified is for installation type B - free inlet, ducted outlet.  
 Power rating (kW) does not include transmission losses.  
 Performance ratings do not include the effects of appurtenances (accessories).

## Technical Data

### Impeller Data

Impeller diameter	$D_r$	510 mm
Number of blades	$z$	12
Moment of Inertia	$J$	0.9 kgm <sup>2</sup>

### Impeller Data

Impeller weight	$m$	19.9 kg
Density of media	$\rho_1$	1.2 kg/m <sup>3</sup>
Tolerance class (DIN 24166)		1

### Speed limits $n_{max}$ for ATEX execution

RZR 11/12	<b>1752</b>	1/min
RZR 18	<b>2000</b>	1/min
RZR 13	<b>2534</b>	1/min

## Performance Curves

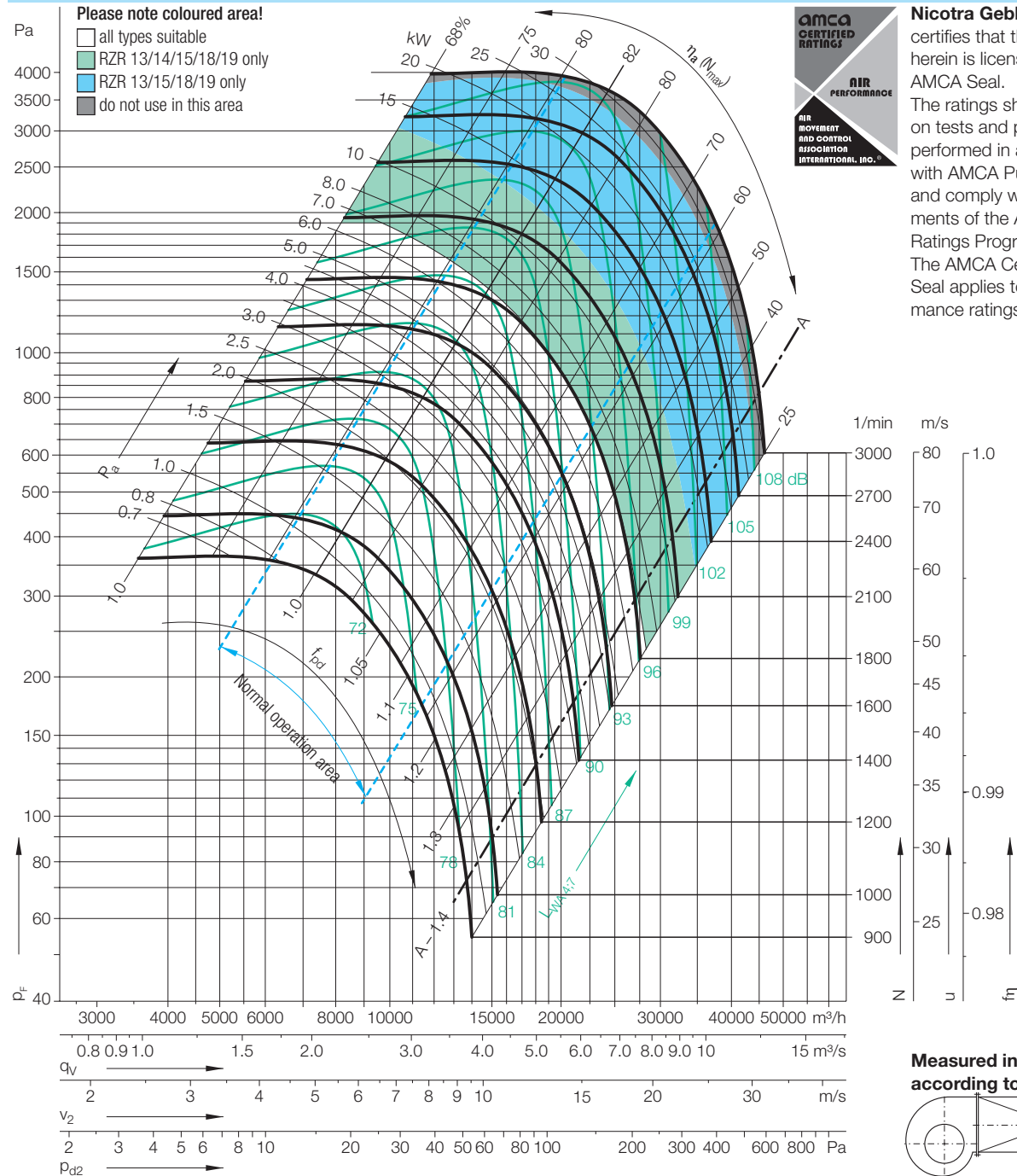

**Nicotra Gebhardt GmbH** certifies that the fan shown herein is licensed to bear the AMCA Seal. The ratings shown are based on tests and procedures performed in accordance with AMCA Publication 211 and comply with the requirements of the AMCA Certified Ratings Program. The AMCA Certified Ratings Seal applies to air performance ratings only.

Relative sound power level for inlet side  $L_{wrel7}$  at octave centre frequencies  $f_m$

Speed	Duty point	63	125	250	500	1000	2000	4000	8000	Hz
≤1498 1/min	≤0.8 $q_{Vopt}$	0	2	0	-3	-6	-9	-12	-19	dB
	>0.8–1.2 $q_{Vopt}$	-2	1	-2	-3	-6	-8	-14	-20	dB
	>1.2–1.6 $q_{Vopt}$	-3	0	-1	-3	-6	-8	-14	-21	dB
	>1.6 $q_{Vopt}$	-5	-3	-3	-3	-6	-7	-13	-21	dB
>1498 1/min	≤0.8 $q_{Vopt}$	-2	-1	-3	-1	-6	-10	-15	-21	dB
	>0.8–1.2 $q_{Vopt}$	-7	-4	-5	-1	-6	-9	-14	-21	dB
	>1.2–1.6 $q_{Vopt}$	-10	-7	-8	-1	-5	-8	-13	-21	dB
	>1.6 $q_{Vopt}$	-10	-8	-8	-2	-6	-8	-11	-18	dB

Relative sound power level for discharge side  $L_{wrel4}$  at octave centre frequencies  $f_m$

Speed	Duty point	63	125	250	500	1000	2000	4000	8000	Hz
≤1498 1/min	≤0.8 $q_{Vopt}$	13	7	4	-3	-8	-14	-17	-25	dB
	>0.8–1.2 $q_{Vopt}$	10	5	3	-2	-7	-13	-17	-25	dB
	>1.2–1.6 $q_{Vopt}$	7	2	2	-2	-6	-12	-18	-27	dB
	>1.6 $q_{Vopt}$	5	1	1	-2	-6	-10	-17	-27	dB
>1498 1/min	≤0.8 $q_{Vopt}$	11	4	2	0	-7	-12	-17	-24	dB
	>0.8–1.2 $q_{Vopt}$	7	1	-2	-3	-6	-10	-15	-23	dB
	>1.2–1.6 $q_{Vopt}$	3	-2	-4	-3	-5	-9	-14	-23	dB
	>1.6 $q_{Vopt}$	2	-3	-5	-3	-5	-9	-12	-21	dB



# RZR-0500

Dimensions in mm, subject to change

**RZR 11-0500** 65 kg

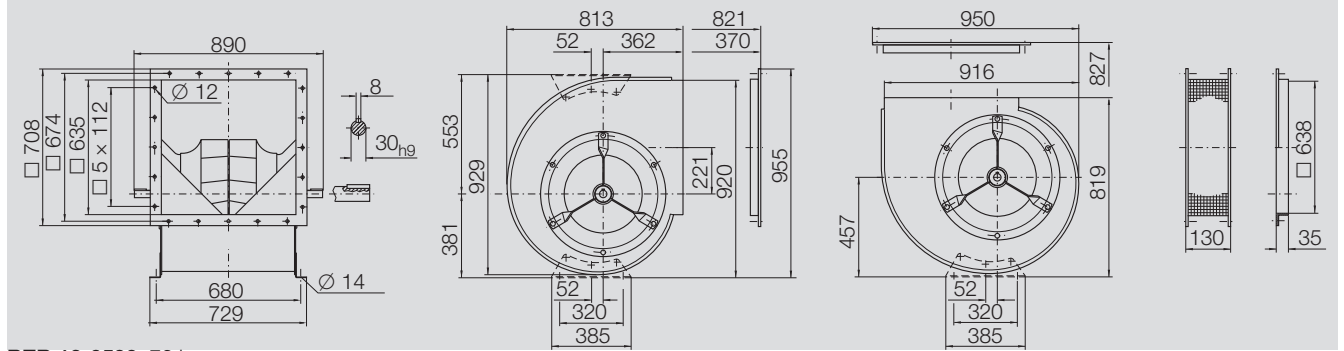

**RZR 12-0500** 72 kg

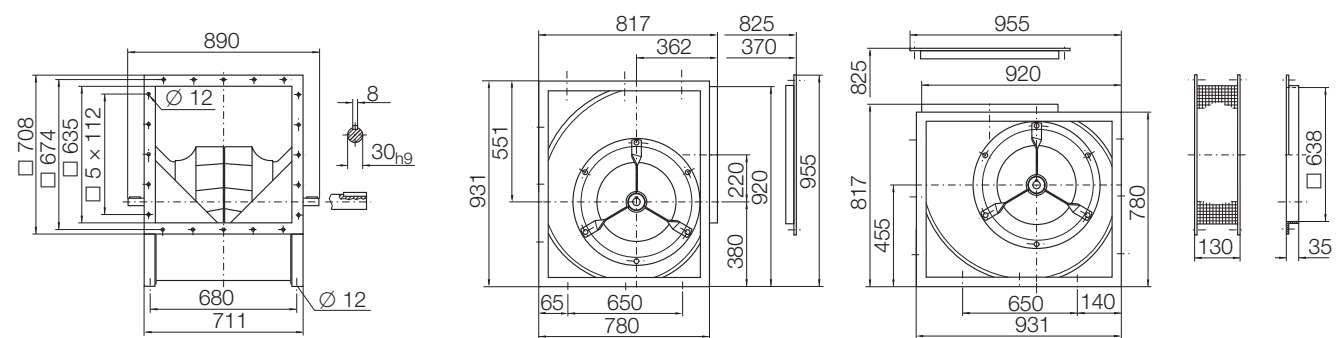

**RZR 14-0500** 98 kg

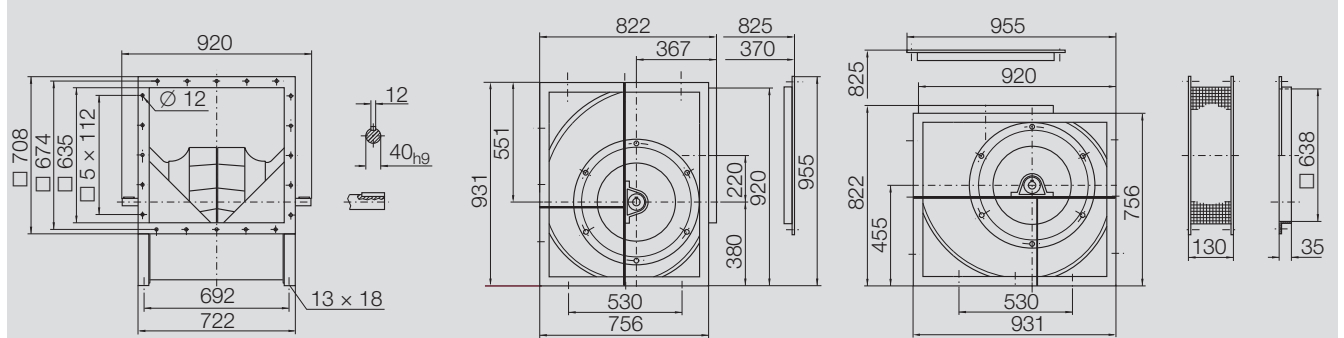

**RZR 15-0500** 94 kg **RZR 19-0500** 105 kg

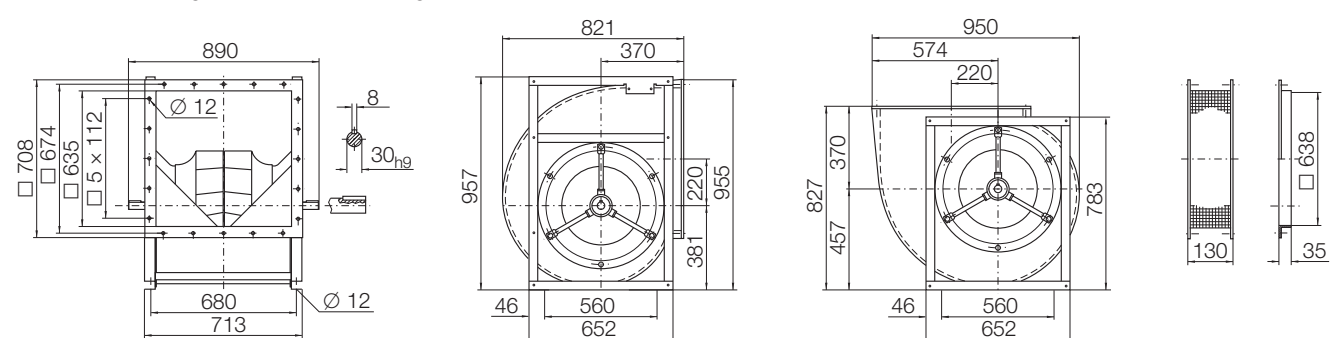

**RZR 18-0500** 105 kg **RZR 13-0500** 116 kg

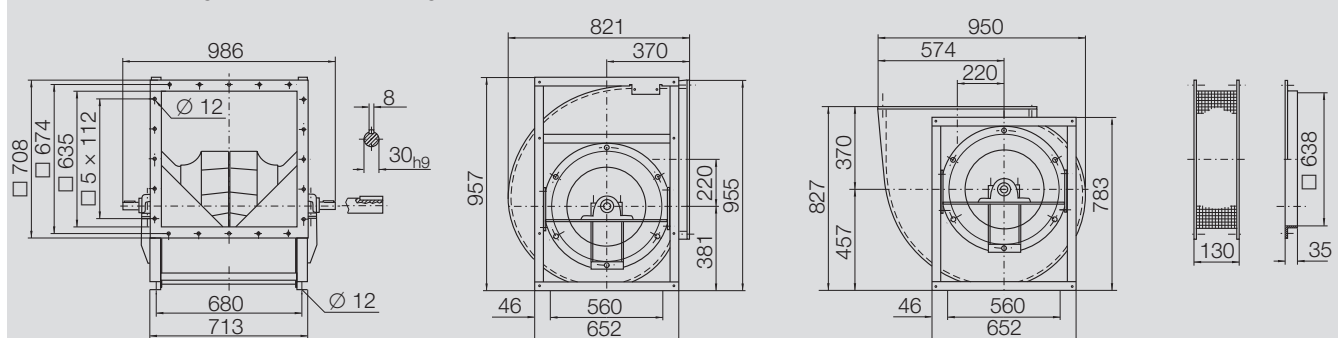

# RZR-0560

Performance certified is for installation type B - free inlet, ducted outlet.  
 Power rating (kW) does not include transmission losses.  
 Performance ratings do not include the effects of appurtenances (accessories).

## Technical Data

### Impeller Data

Impeller diameter	$D_r$	570 mm
Number of blades	$z$	12
Moment of Inertia	$J$	1.7 kgm <sup>2</sup>

### Impeller Data

Impeller weight	$m$	30 kg
Density of media	$\rho_1$	1.2 kg/m <sup>3</sup>
Tolerance class (DIN 24166)		1

### Speed limits $n_{max}$ for ATEX execution

RZR 11/12/18	<b>1660</b>	1/min
RZR 13	<b>2163</b>	1/min

## Performance Curves

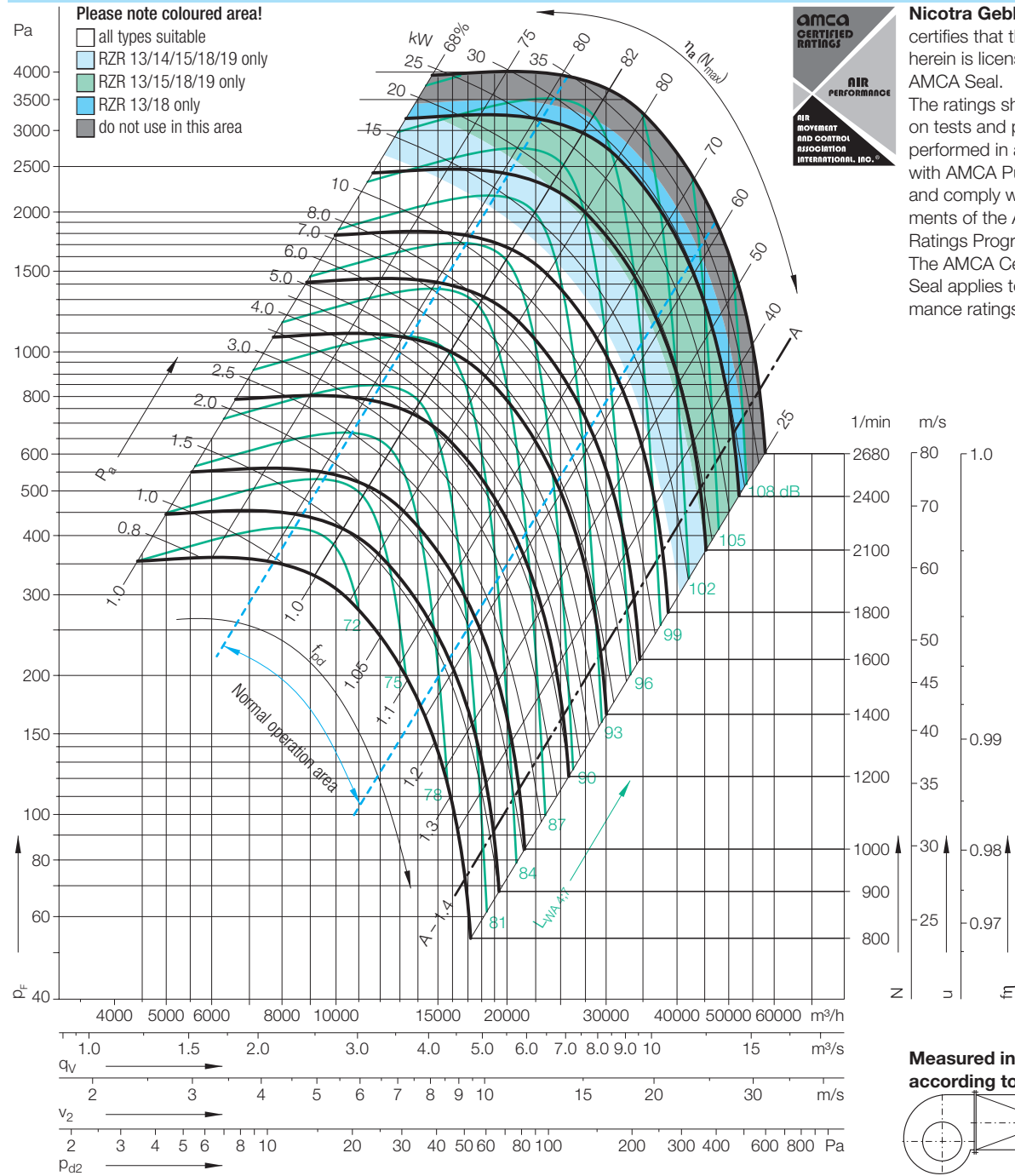

Measured in installation B according to ISO 5801:

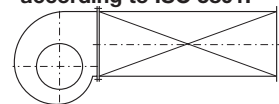

Relative sound power level for inlet side  $L_{Wrel7}$  at octave centre frequencies  $f_m$

Speed	Duty point	63	125	250	500	1000	2000	4000	8000	Hz
≤1340 1/min	≤0.8 $q_{Vopt}$	0	2	0	-3	-6	-9	-12	-19	dB
	>0.8–1.2 $q_{Vopt}$	-2	1	-2	-3	-6	-8	-14	-20	dB
	>1.2–1.6 $q_{Vopt}$	-3	0	-1	-3	-6	-8	-14	-21	dB
	>1.6–2.0 $q_{Vopt}$	-5	-3	-3	-3	-6	-7	-13	-21	dB
	>2.0 $q_{Vopt}$	-5	-3	-3	-3	-6	-7	-13	-21	dB
>1340 1/min	≤0.8 $q_{Vopt}$	-2	-1	-3	-1	-6	-10	-15	-21	dB
	>0.8–1.2 $q_{Vopt}$	-7	-4	-5	-1	-6	-9	-14	-21	dB
	>1.2–1.6 $q_{Vopt}$	-10	-7	-8	-1	-5	-8	-13	-21	dB
	>1.6–2.0 $q_{Vopt}$	-10	-8	-8	-2	-6	-8	-11	-18	dB
	>2.0 $q_{Vopt}$	-10	-8	-8	-2	-6	-8	-11	-18	dB

Relative sound power level for discharge side  $L_{Wrel4}$  at octave centre frequencies  $f_m$

Speed	Duty point	63	125	250	500	1000	2000	4000	8000	Hz
≤1340 1/min	≤0.8 $q_{Vopt}$	13	7	4	-3	-8	-14	-17	-25	dB
	>0.8–1.2 $q_{Vopt}$	10	5	3	-2	-7	-13	-17	-25	dB
	>1.2–1.6 $q_{Vopt}$	7	2	2	-2	-6	-12	-18	-27	dB
	>1.6–2.0 $q_{Vopt}$	5	1	1	-2	-6	-10	-17	-27	dB
	>2.0 $q_{Vopt}$	5	1	1	-2	-6	-10	-17	-27	dB
>1340 1/min	≤0.8 $q_{Vopt}$	11	4	2	0	-7	-12	-17	-24	dB
	>0.8–1.2 $q_{Vopt}$	7	1	-2	-3	-6	-10	-15	-23	dB
	>1.2–1.6 $q_{Vopt}$	3	-2	-4	-3	-5	-9	-14	-23	dB
	>1.6–2.0 $q_{Vopt}$	2	-3	-5	-3	-5	-9	-12	-21	dB
	>2.0 $q_{Vopt}$	2	-3	-5	-3	-5	-9	-12	-21	dB

# RZR-0560

Dimensions in mm, subject to change

**RZR 11-0560** 103 kg

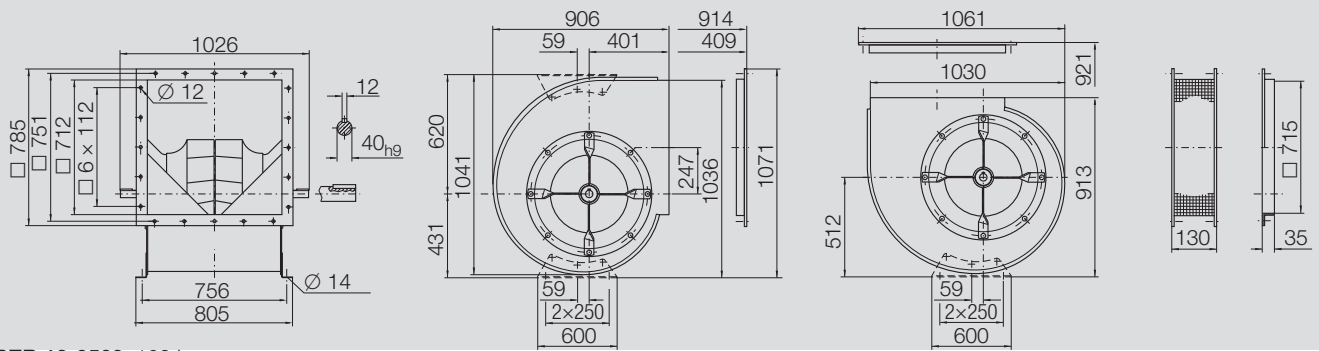

**RZR 12-0560** 109 kg

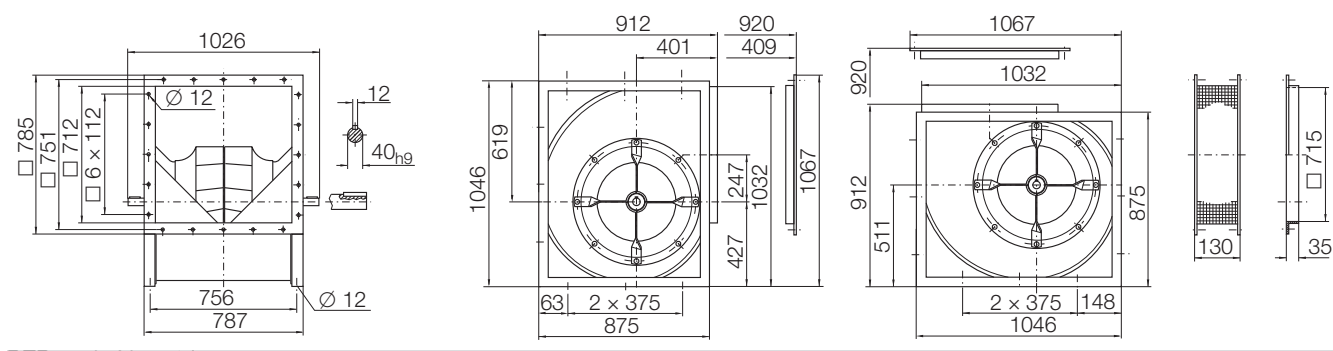

**RZR 14-0560** 156 kg

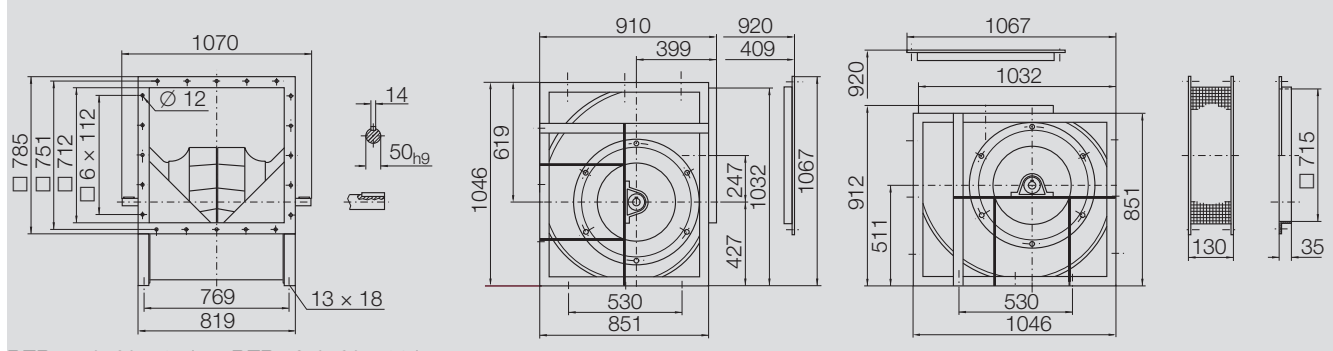

**RZR 15-0560** 125 kg **RZR 19-0560** 136 kg

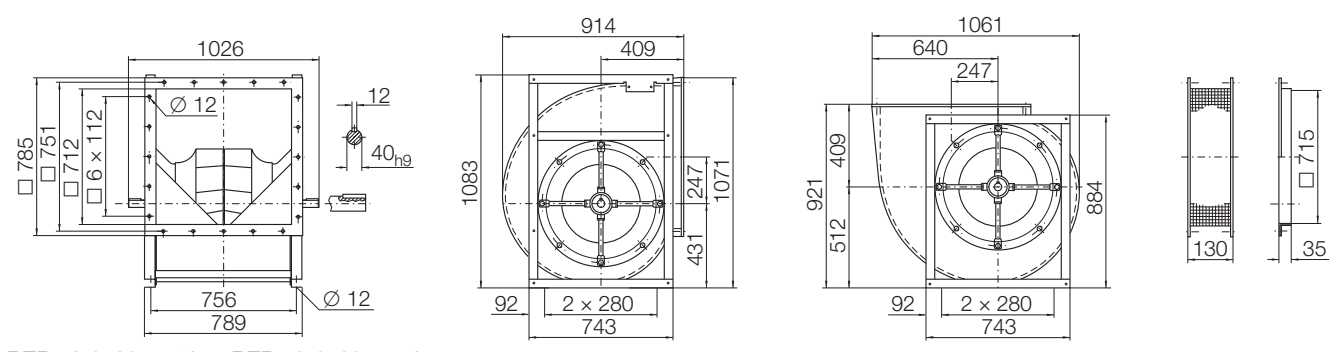

**RZR 18-0560** 140 kg **RZR 13-0560** 151 kg

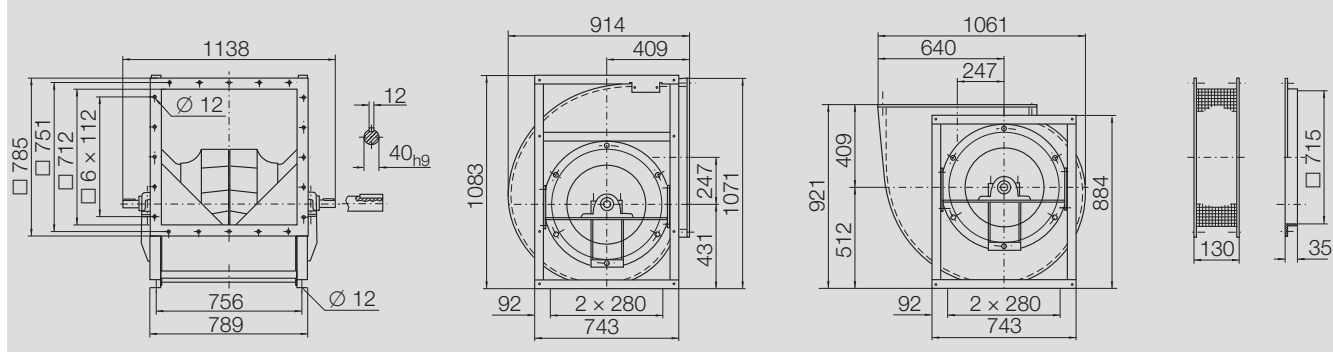

# RZR-0630

Performance certified is for installation type B - free inlet, ducted outlet.  
 Power rating (kW) does not include transmission losses.  
 Performance ratings do not include the effects of appurtenances (accessories).

## Technical Data

### Impeller Data

Impeller diameter	$D_r$	640 mm
Number of blades	$z$	12
Moment of Inertia	$J$	2.4 kgm <sup>2</sup>

### Impeller Data

Impeller weight	$m$	38 kg
Density of media	$\rho_1$	1.2 kg/m <sup>3</sup>
Tolerance class (DIN 24166)		1

### Speed limits $n_{max}$ for ATEX execution

RZR 11/12/18	<b>1367</b>	1/min
RZR 13	<b>2055</b>	1/min

## Performance Curves

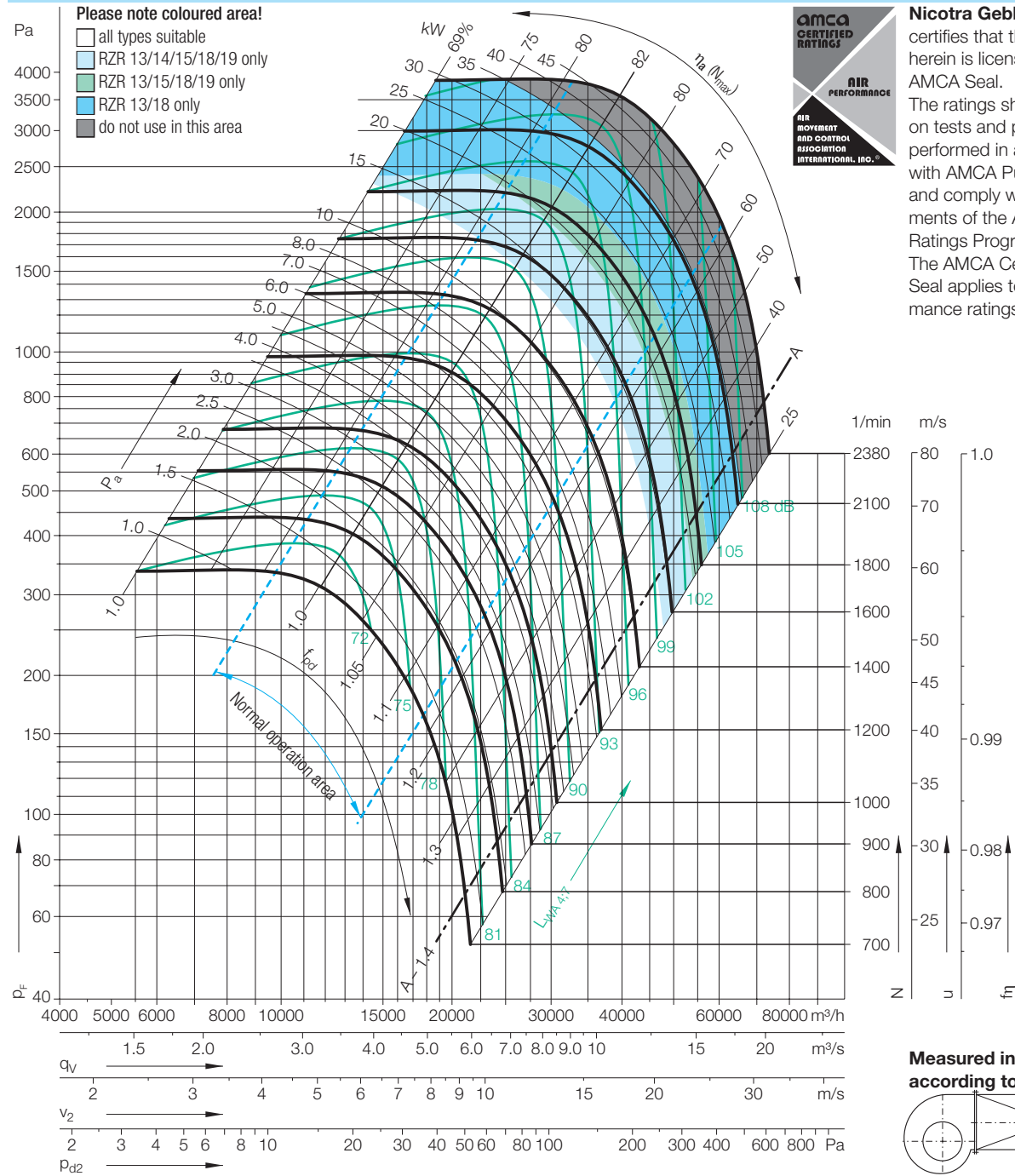

**Nicotra Gebhardt GmbH** certifies that the fan shown herein is licensed to bear the AMCA Seal. The ratings shown are based on tests and procedures performed in accordance with AMCA Publication 211 and comply with the requirements of the AMCA Certified Ratings Program. The AMCA Certified Ratings Seal applies to air performance ratings only.

Speed	Duty point
≤1194 1/min	≤0.8 $q_{Vopt}$
	>0.8–1.2 $q_{Vopt}$
	>1.2–1.6 $q_{Vopt}$
	>1.6 $q_{Vopt}$
Speed	Duty point
>1194 1/min	≤0.8 $q_{Vopt}$
	>0.8–1.2 $q_{Vopt}$
	>1.2–1.6 $q_{Vopt}$
	>1.6 $q_{Vopt}$

Relative sound power level for inlet side  $L_{Wrel7}$  at octave centre frequencies  $f_m$

63	125	250	500	1000	2000	4000	8000	Hz
0	2	0	-3	-6	-9	-12	-19	dB
-2	1	-2	-3	-6	-8	-14	-20	dB
-3	0	-1	-3	-6	-8	-14	-21	dB
-5	-3	-3	-3	-6	-7	-13	-21	dB
63	125	250	500	1000	2000	4000	8000	Hz
-2	-1	-3	-1	-6	-10	-15	-21	dB
-7	-4	-5	-1	-6	-9	-14	-21	dB
-10	-7	-8	-1	-5	-8	-13	-21	dB
-10	-8	-8	-2	-6	-8	-11	-18	dB

Relative sound power level for discharge side  $L_{Wrel4}$  at octave centre frequencies  $f_m$

63	125	250	500	1000	2000	4000	8000	Hz
13	7	4	-3	-8	-14	-17	-25	dB
10	5	3	-2	-7	-13	-17	-25	dB
7	2	2	-2	-6	-12	-18	-27	dB
5	1	1	-2	-6	-10	-17	-27	dB
63	125	250	500	1000	2000	4000	8000	Hz
11	4	2	0	-7	-12	-17	-24	dB
7	1	-2	-3	-6	-10	-15	-23	dB
3	-2	-4	-3	-5	-9	-14	-23	dB
2	-3	-5	-3	-5	-9	-12	-21	dB

# RZR-0630

Dimensions in mm, subject to change

**RZR 11-0630** 124 kg

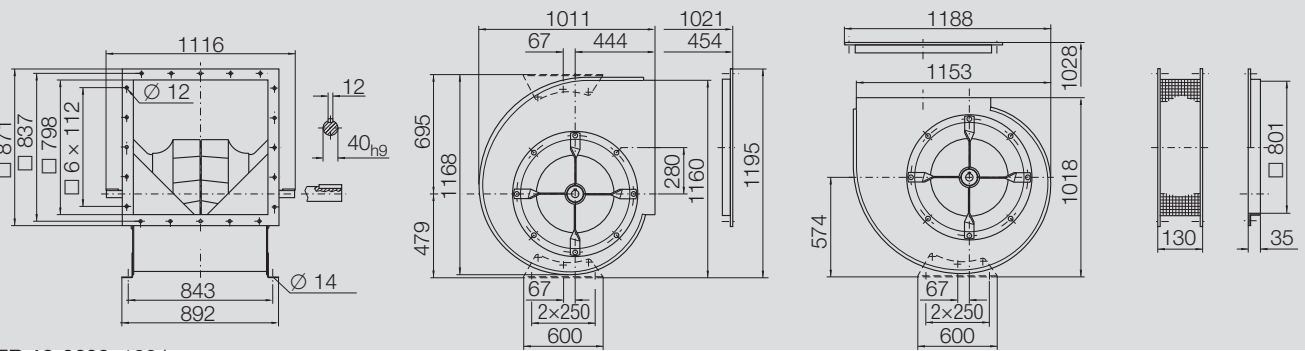

**RZR 12-0630** 132 kg

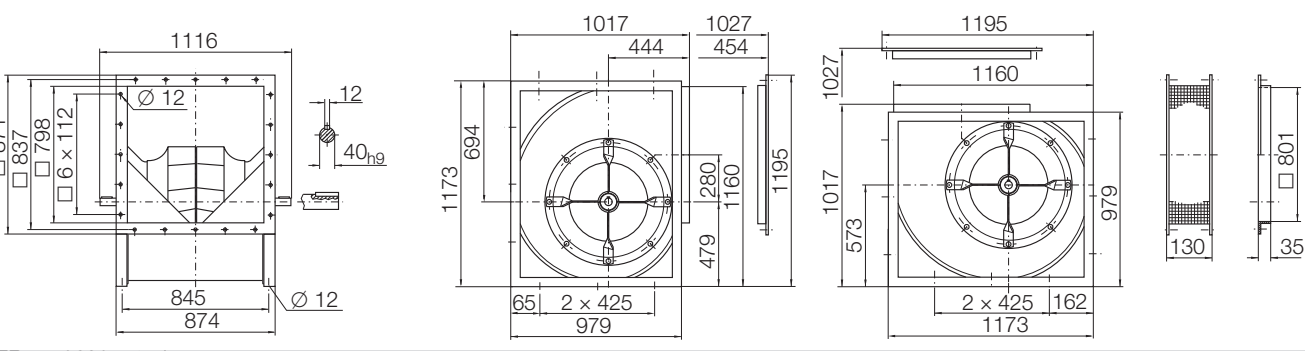

**RZR 14-0630** 185 kg

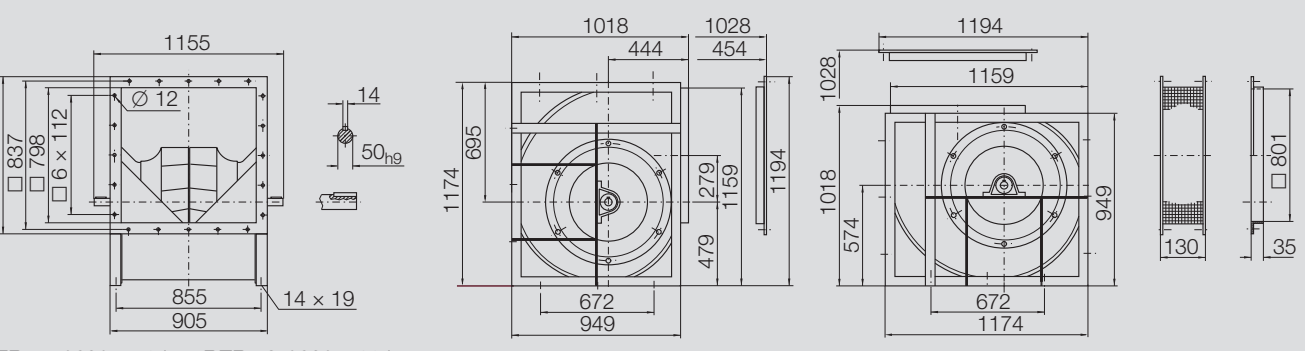

**RZR 15-0630** 149 kg **RZR 19-0630** 162 kg

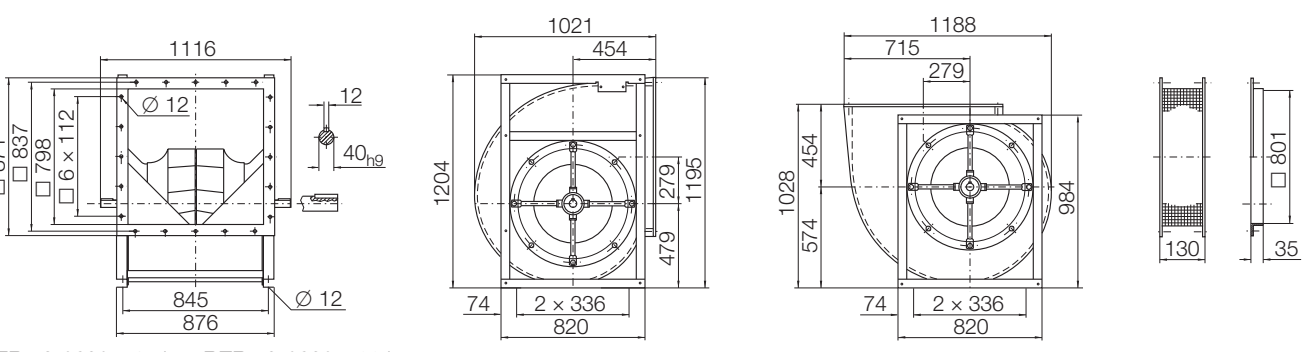

**RZR 18-0630** 167 kg **RZR 13-0630** 180 kg

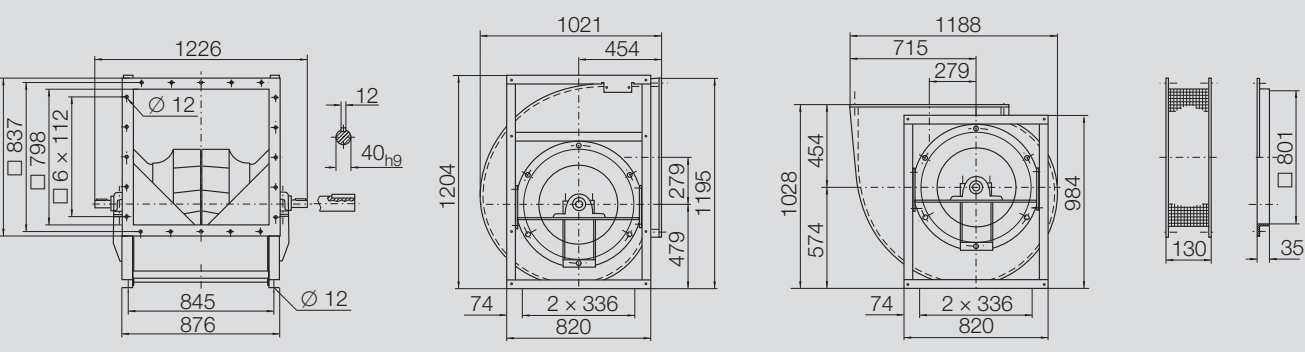

# RZR-0710

Performance certified is for installation type B - free inlet, ducted outlet.  
 Power rating (kW) does not include transmission losses.  
 Performance ratings do not include the effects of appurtenances (accessories).

## Technical Data

### Impeller Data

Impeller diameter	$D_r$	718 mm
Number of blades	$z$	12
Moment of Inertia	$J$	4.8 kgm <sup>2</sup>

### Impeller Data

Impeller weight	$m$	52 kg
Density of media	$\rho_1$	1.2 kg/m <sup>3</sup>
Tolerance class (DIN 24166)		1

### Speed limits $n_{max}$ for ATEX execution

RZR 11/12/18	<b>1128</b>	1/min
RZR 13	<b>1825</b>	1/min

## Performance Curves

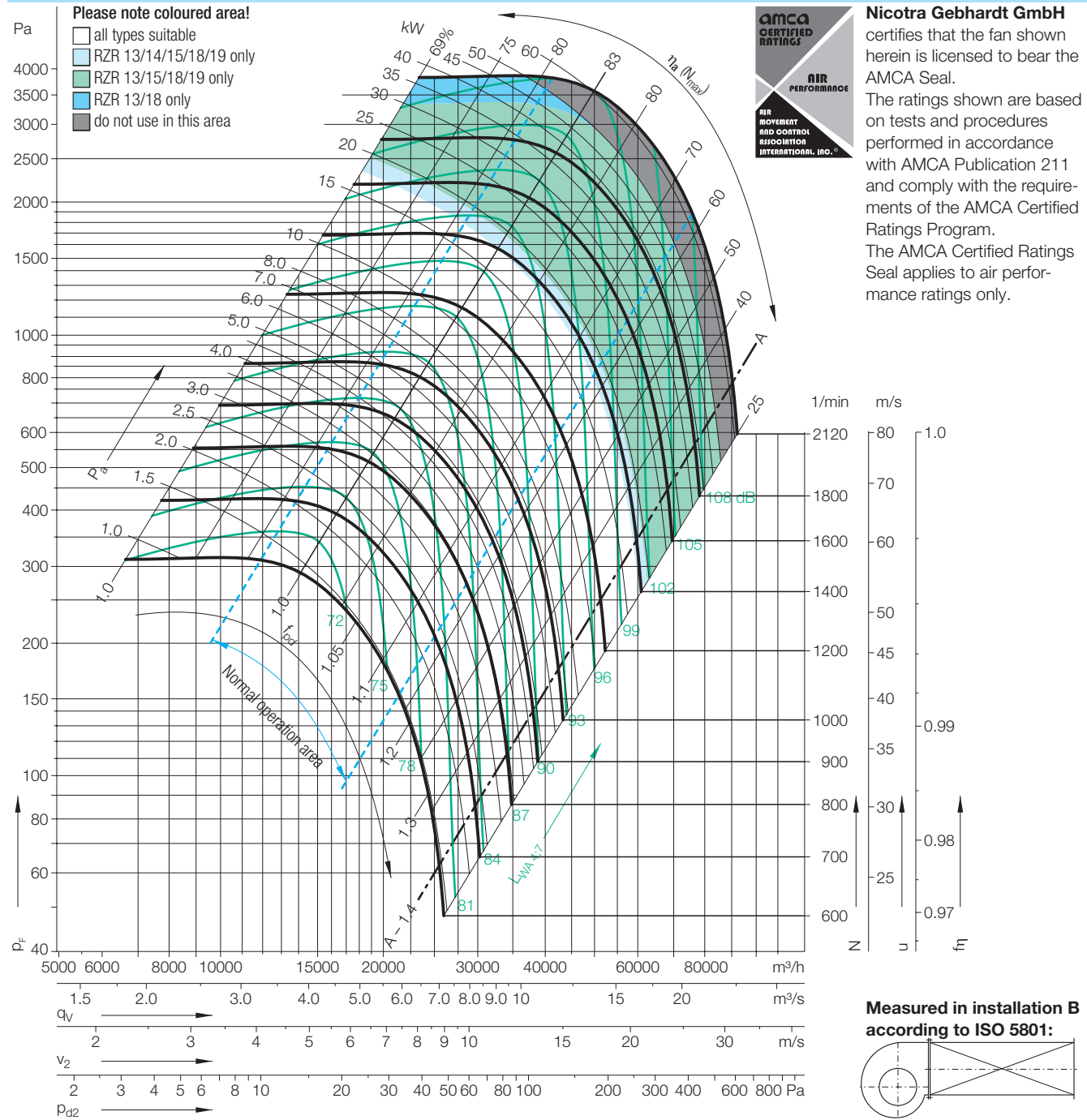

Measured in installation B according to ISO 5801:

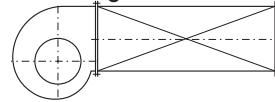

Relative sound power level for inlet side  $L_{Wrel7}$  at octave centre frequencies  $f_m$

Speed	Duty point	63	125	250	500	1000	2000	4000	8000	Hz
≤1064 1/min	≤0.8 $q_{Vopt}$	0	2	0	-3	-6	-9	-12	-19	dB
	>0.8–1.2 $q_{Vopt}$	-2	1	-2	-3	-6	-8	-14	-20	dB
	>1.2–1.6 $q_{Vopt}$	-3	0	-1	-3	-6	-8	-14	-21	dB
	>1.6–2.0 $q_{Vopt}$	-5	-3	-3	-3	-6	-7	-13	-21	dB
	>2.0 $q_{Vopt}$	-5	-3	-3	-3	-6	-7	-13	-21	dB
>1064 1/min	≤0.8 $q_{Vopt}$	-2	-1	-3	-1	-6	-10	-15	-21	dB
	>0.8–1.2 $q_{Vopt}$	-7	-4	-5	-1	-6	-9	-14	-21	dB
	>1.2–1.6 $q_{Vopt}$	-10	-7	-8	-1	-5	-8	-13	-21	dB
	>1.6–2.0 $q_{Vopt}$	-10	-8	-8	-2	-6	-8	-11	-18	dB
	>2.0 $q_{Vopt}$	-10	-8	-8	-2	-6	-8	-11	-18	dB

Relative sound power level for discharge side  $L_{Wrel4}$  at octave centre frequencies  $f_m$

Speed	Duty point	63	125	250	500	1000	2000	4000	8000	Hz
≤1064 1/min	≤0.8 $q_{Vopt}$	13	7	4	-3	-8	-14	-17	-25	dB
	>0.8–1.2 $q_{Vopt}$	10	5	3	-2	-7	-13	-17	-25	dB
	>1.2–1.6 $q_{Vopt}$	7	2	2	-2	-6	-12	-18	-27	dB
	>1.6–2.0 $q_{Vopt}$	5	1	1	-2	-6	-10	-17	-27	dB
	>2.0 $q_{Vopt}$	5	1	1	-2	-6	-10	-17	-27	dB
>1064 1/min	≤0.8 $q_{Vopt}$	11	4	2	0	-7	-12	-17	-24	dB
	>0.8–1.2 $q_{Vopt}$	7	1	-2	-3	-6	-10	-15	-23	dB
	>1.2–1.6 $q_{Vopt}$	3	-2	-4	-3	-5	-9	-14	-23	dB
	>1.6–2.0 $q_{Vopt}$	2	-3	-5	-3	-5	-9	-12	-21	dB
	>2.0 $q_{Vopt}$	2	-3	-5	-3	-5	-9	-12	-21	dB

# RZR-0710

Dimensions in mm, subject to change

**RZR 11-0710** 177 kg

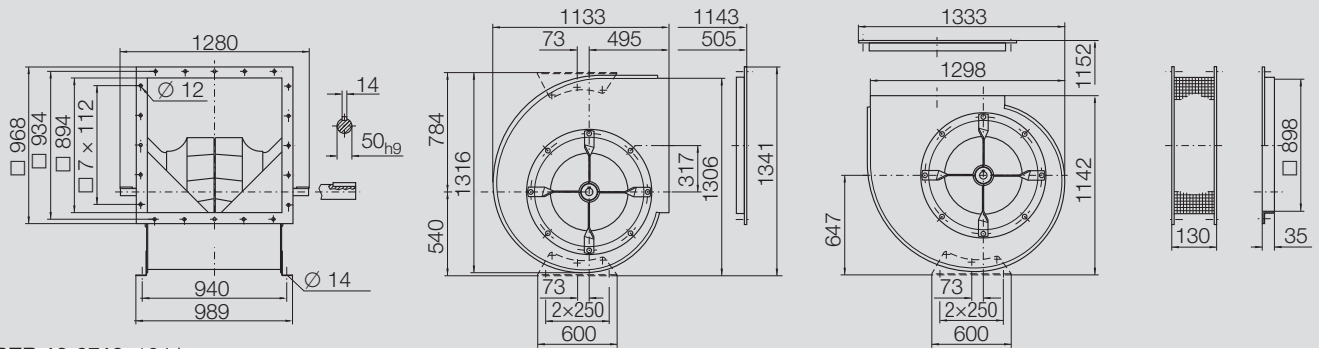

**RZR 12-0710** 194 kg

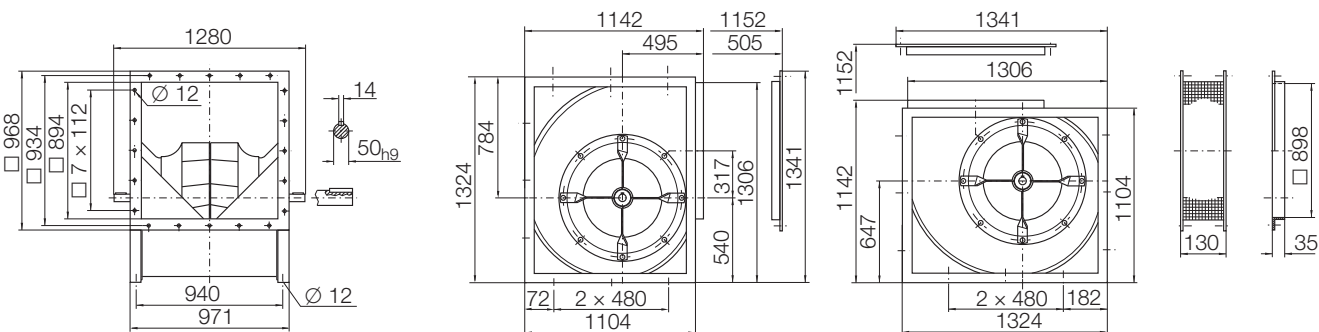

**RZR 14-0710** 230 kg

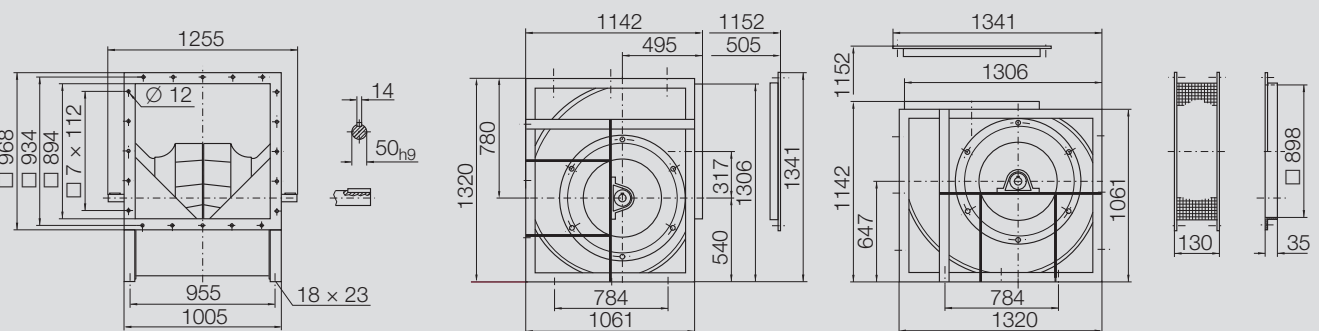

**RZR 15-0710** 201 kg **RZR 19-0710** 225 kg

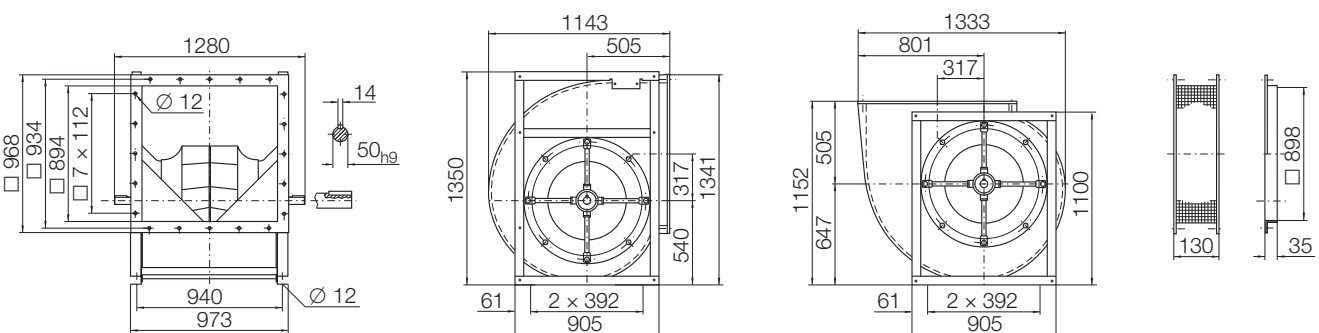

**RZR 18-0710** 230 kg **RZR 13-0710** 254 kg

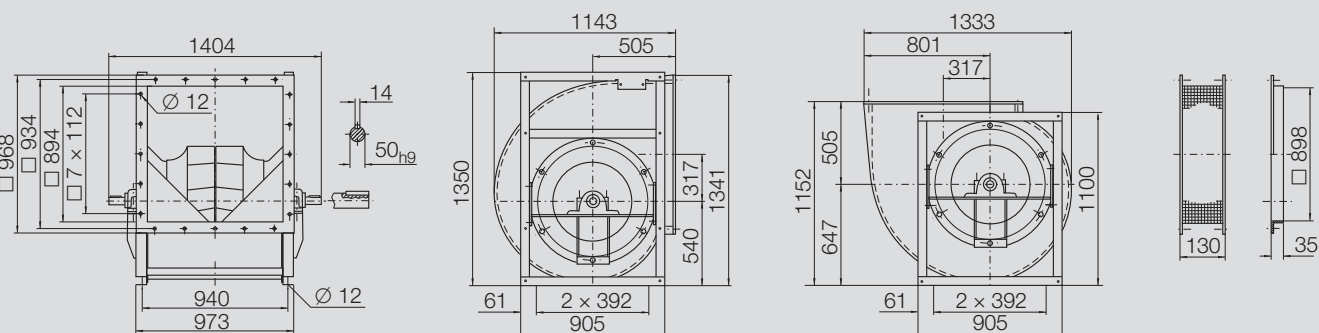

# RZR-0800

Performance certified is for installation type B - free inlet, ducted outlet.  
 Power rating (kW) does not include transmission losses.  
 Performance ratings do not include the effects of appurtenances (accessories).

## Technical Data

### Impeller Data

Impeller diameter	$D_r$	808 mm
Number of blades	$z$	12
Moment of Inertia	$J$	6.85 kgm <sup>2</sup>

### Impeller Data

Impeller weight	$m$	69 kg
Density of media	$\rho_1$	1.2 kg/m <sup>3</sup>
Tolerance class (DIN 24166)		1

### Speed limits $n_{max}$ for ATEX execution

RZR 11/18	<b>927</b>	1/min
RZR 13	<b>1474</b>	1/min

## Performance Curves

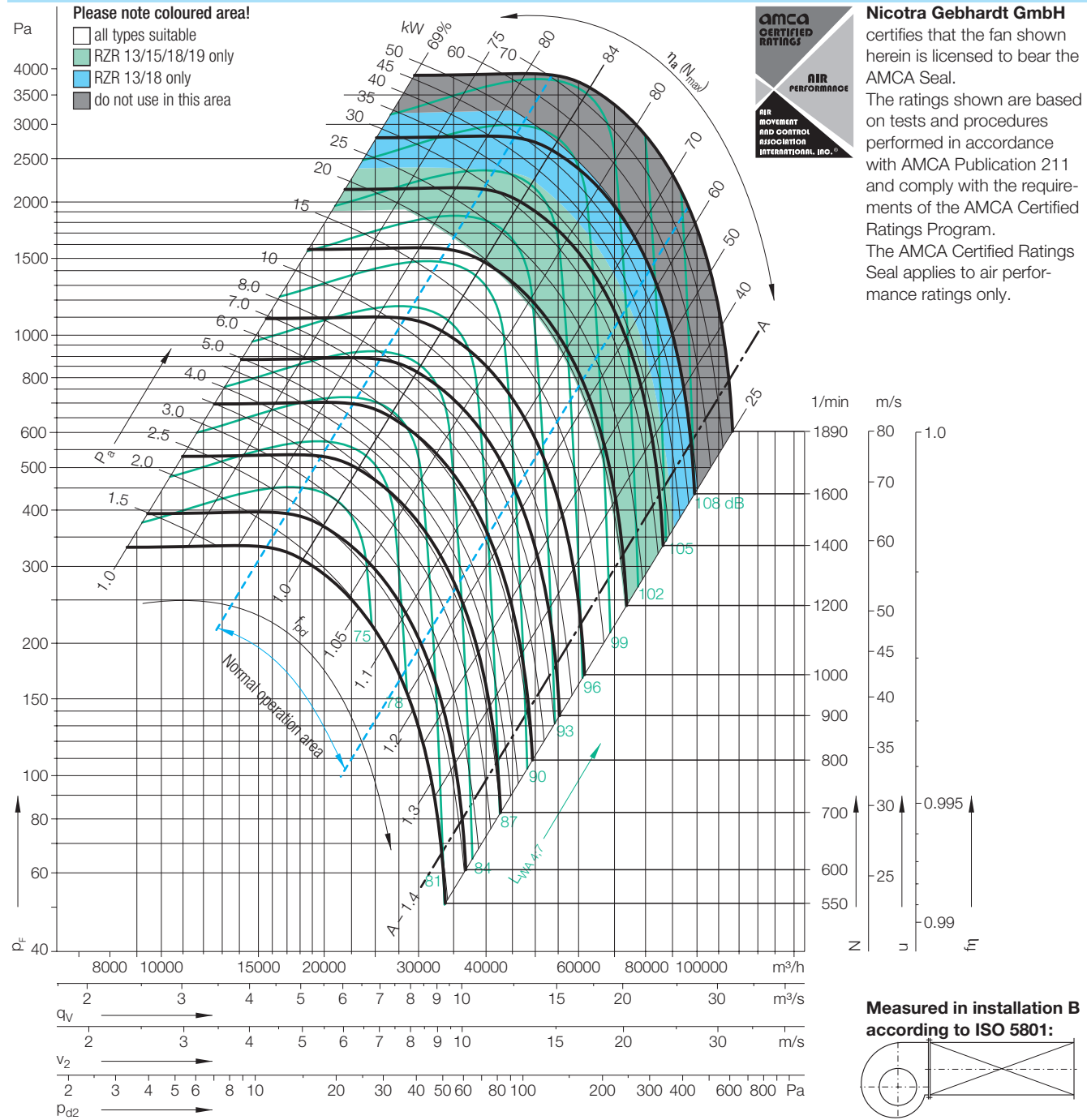

Measured in installation B according to ISO 5801:

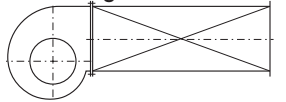

Relative sound power level for inlet side  $L_{Wrel7}$  at octave centre frequencies  $f_m$

Speed	Duty point	63	125	250	500	1000	2000	4000	8000	Hz
$\leq 945$ 1/min	$\leq 0.8 q_{Vopt}$	0	2	0	-3	-6	-9	-12	-19	dB
	$> 0.8 - 1.2 q_{Vopt}$	-2	1	-2	-3	-6	-8	-14	-20	dB
	$> 1.2 - 1.6 q_{Vopt}$	-3	0	-1	-3	-6	-8	-14	-21	dB
	$> 1.6 - 2.0 q_{Vopt}$	-5	-3	-3	-3	-6	-7	-13	-21	dB
	$> 2.0 q_{Vopt}$	-5	-3	-3	-3	-6	-7	-13	-21	dB
$> 945$ 1/min	$\leq 0.8 q_{Vopt}$	-2	-1	-3	-1	-6	-10	-15	-21	dB
	$> 0.8 - 1.2 q_{Vopt}$	-7	-4	-5	-1	-6	-9	-14	-21	dB
	$> 1.2 - 1.6 q_{Vopt}$	-10	-7	-8	-1	-5	-8	-13	-21	dB
	$> 1.6 - 2.0 q_{Vopt}$	-10	-8	-8	-2	-6	-8	-11	-18	dB
	$> 2.0 q_{Vopt}$	-10	-8	-8	-2	-6	-8	-11	-18	dB

Relative sound power level for discharge side  $L_{Wrel4}$  at octave centre frequencies  $f_m$

Speed	Duty point	63	125	250	500	1000	2000	4000	8000	Hz
$\leq 945$ 1/min	$\leq 0.8 q_{Vopt}$	13	7	4	-3	-8	-14	-17	-25	dB
	$> 0.8 - 1.2 q_{Vopt}$	10	5	3	-2	-7	-13	-17	-25	dB
	$> 1.2 - 1.6 q_{Vopt}$	7	2	2	-2	-6	-12	-18	-27	dB
	$> 1.6 - 2.0 q_{Vopt}$	5	1	1	-2	-6	-10	-17	-27	dB
	$> 2.0 q_{Vopt}$	5	1	1	-2	-6	-10	-17	-27	dB
$> 945$ 1/min	$\leq 0.8 q_{Vopt}$	11	4	2	0	-7	-12	-17	-24	dB
	$> 0.8 - 1.2 q_{Vopt}$	7	1	-2	-3	-6	-10	-15	-23	dB
	$> 1.2 - 1.6 q_{Vopt}$	3	-2	-4	-3	-5	-9	-14	-23	dB
	$> 1.6 - 2.0 q_{Vopt}$	2	-3	-5	-3	-5	-9	-12	-21	dB
	$> 2.0 q_{Vopt}$	2	-3	-5	-3	-5	-9	-12	-21	dB



# RZR-0800

Dimensions in mm, subject to change

**RZR 11-0800** 250 kg

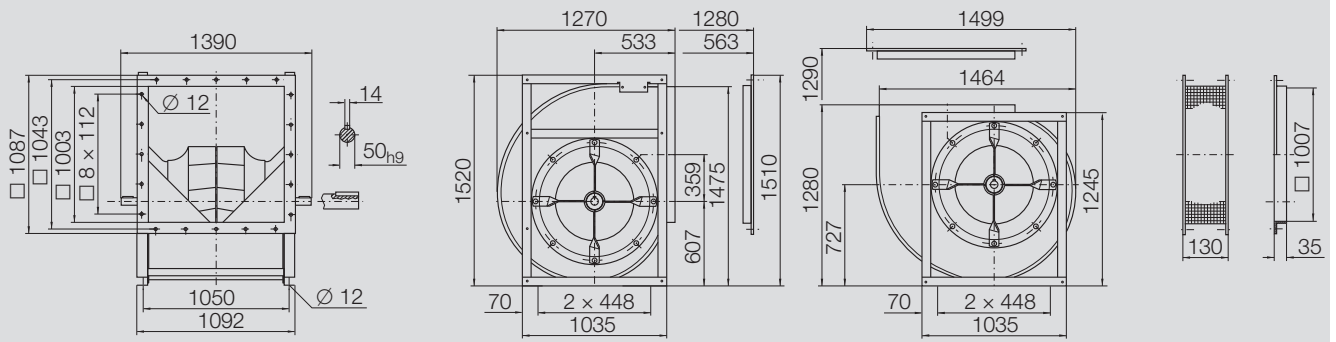

**RZR 14-0800** 327 kg

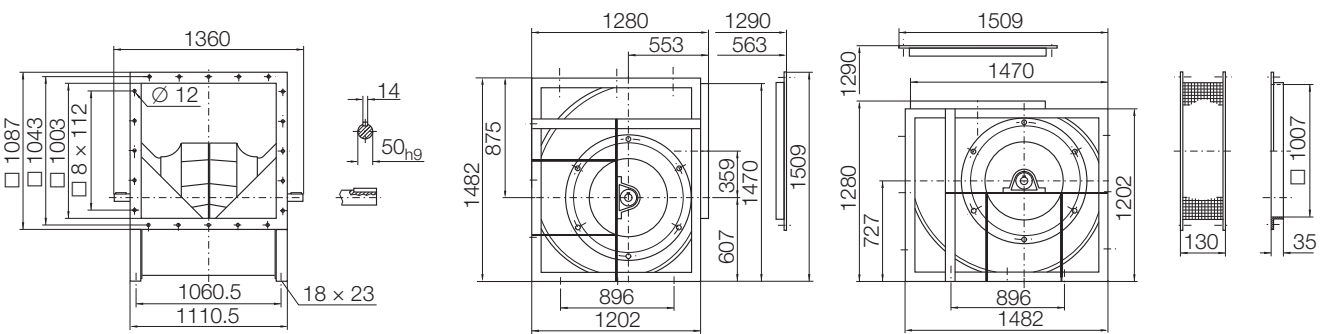

**RZR 15-0800** 250 kg

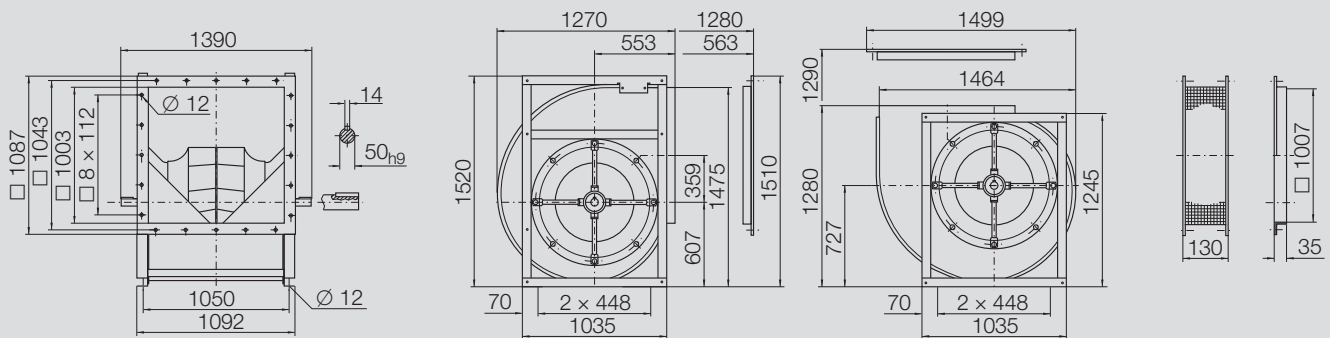

**RZR 19-0800** 280 kg

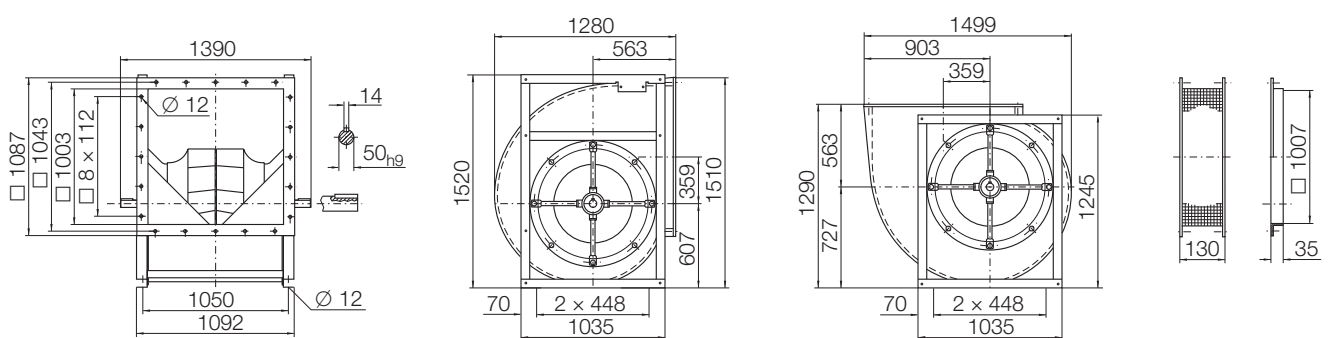

**RZR 18-0800** 289 kg **RZR 13-0800** 319 kg

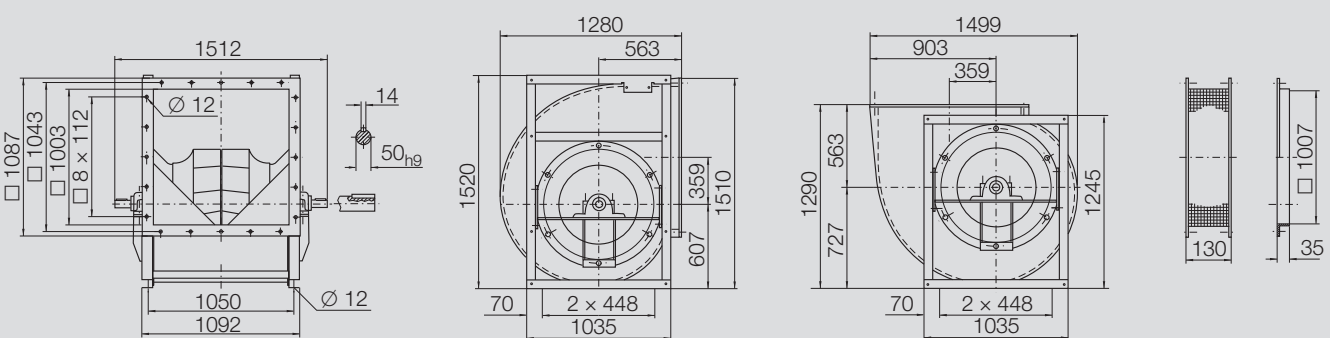

# RZR-0900

Performance certified is for installation type B - free inlet, ducted outlet.  
 Power rating (kW) does not include transmission losses.  
 Performance ratings do not include the effects of appurtenances (accessories).

## Technical Data

### Impeller Data

Impeller diameter	$D_r$	905 mm
Number of blades	$z$	12
Moment of Inertia	$J$	15.5 kgm <sup>2</sup>

### Impeller Data

Impeller weight	$m$	109 kg
Density of media	$\rho_1$	1.2 kg/m <sup>3</sup>
Tolerance class (DIN 24166)		1

### Speed limits $n_{max}$ for ATEX execution

RZR 11/18	<b>767</b>	1/min
RZR 13	<b>1339</b>	1/min

## Performance Curves

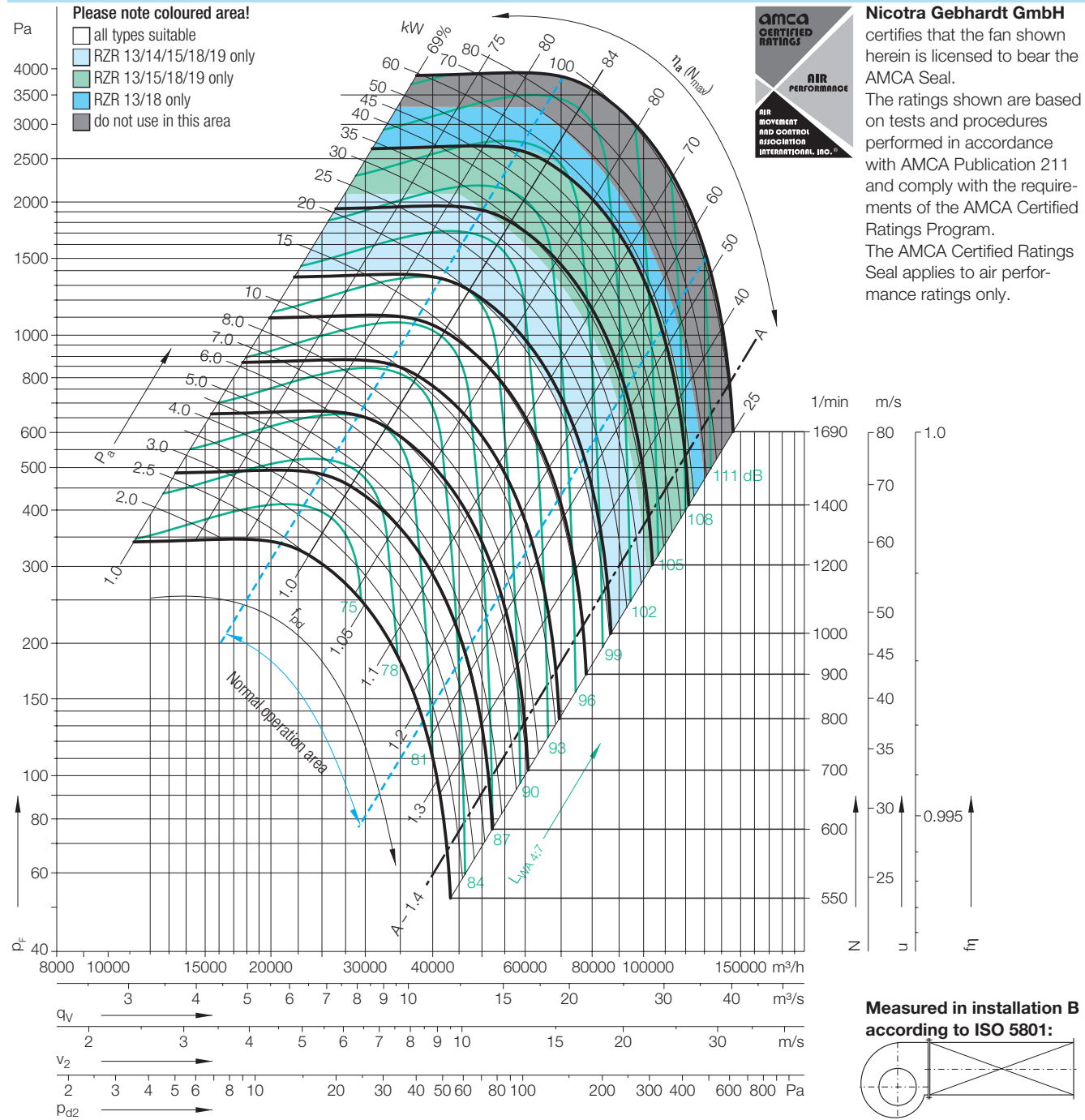

Measured in installation B according to ISO 5801:

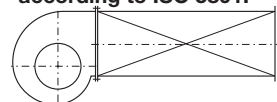

Relative sound power level for inlet side  $L_{wrel7}$  at octave centre frequencies  $f_m$

Speed	Duty point	63	125	250	500	1000	2000	4000	8000	Hz
$\leq 844$ 1/min	$\leq 0.8 q_{Vopt}$	0	2	0	-3	-6	-9	-12	-19	dB
	$> 0.8 - 1.2 q_{Vopt}$	-2	1	-2	-3	-6	-8	-14	-20	dB
	$> 1.2 - 1.6 q_{Vopt}$	-3	0	-1	-3	-6	-8	-14	-21	dB
	$> 1.6 q_{Vopt}$	-5	-3	-3	-3	-6	-7	-13	-21	dB
$> 844$ 1/min	$\leq 0.8 q_{Vopt}$	-2	-1	-3	-1	-6	-10	-15	-21	dB
	$> 0.8 - 1.2 q_{Vopt}$	-7	-4	-5	-1	-6	-9	-14	-21	dB
	$> 1.2 - 1.6 q_{Vopt}$	-10	-7	-8	-1	-5	-8	-13	-21	dB
	$> 1.6 q_{Vopt}$	-10	-8	-8	-2	-6	-8	-11	-18	dB

Relative sound power level for discharge side  $L_{wrel4}$  at octave centre frequencies  $f_m$

Speed	Duty point	63	125	250	500	1000	2000	4000	8000	Hz
$\leq 844$ 1/min	$\leq 0.8 q_{Vopt}$	13	7	4	-3	-8	-14	-17	-25	dB
	$> 0.8 - 1.2 q_{Vopt}$	10	5	3	-2	-7	-13	-17	-25	dB
	$> 1.2 - 1.6 q_{Vopt}$	7	2	2	-2	-6	-12	-18	-27	dB
	$> 1.6 q_{Vopt}$	5	1	1	-2	-6	-10	-17	-27	dB
$> 844$ 1/min	$\leq 0.8 q_{Vopt}$	11	4	2	0	-7	-12	-17	-24	dB
	$> 0.8 - 1.2 q_{Vopt}$	7	1	-2	-3	-6	-10	-15	-23	dB
	$> 1.2 - 1.6 q_{Vopt}$	3	-2	-4	-3	-5	-9	-14	-23	dB
	$> 1.6 q_{Vopt}$	2	-3	-5	-3	-5	-9	-12	-21	dB

# RZR-0900

Dimensions in mm, subject to change

**RZR 11-0900** 358 kg

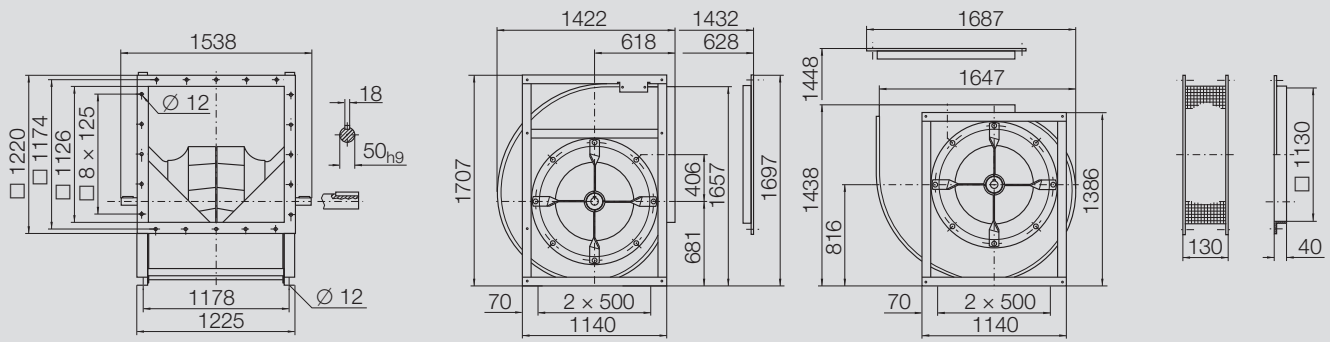

**RZR 14-0900** 356 kg

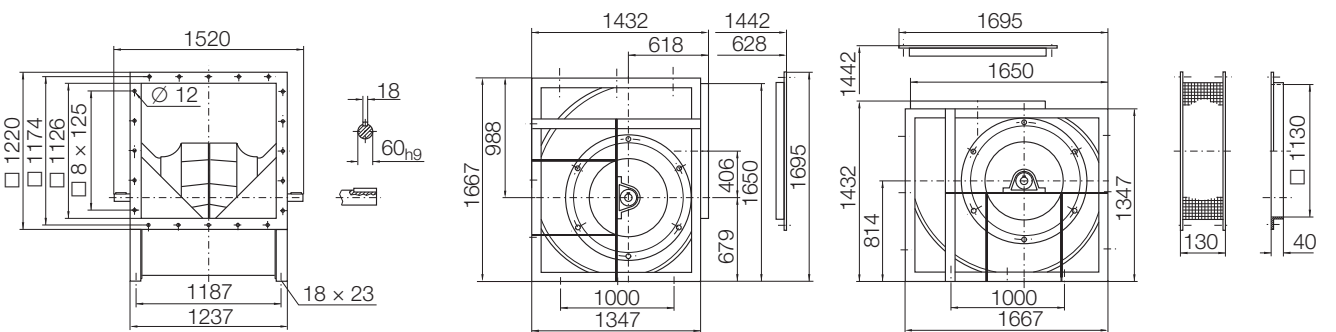

**RZR 15-0900** 358 kg

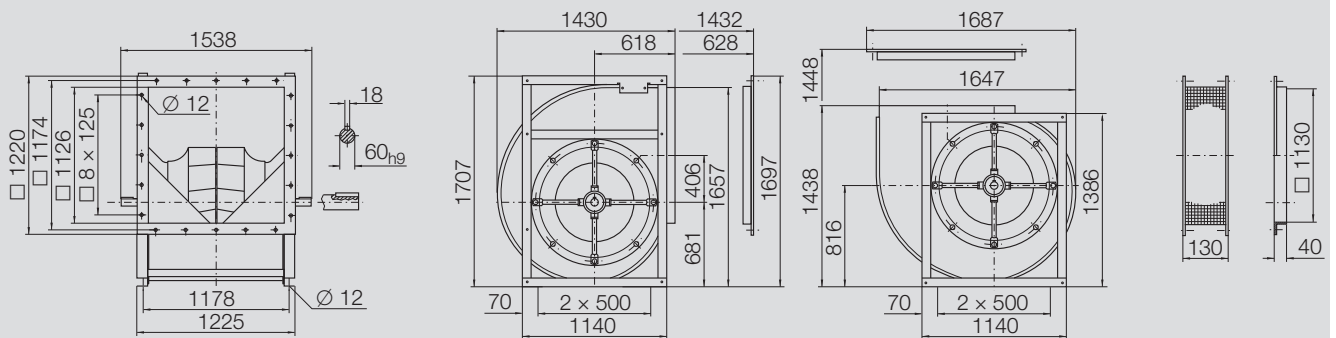

**RZR 19-0900** 396 kg

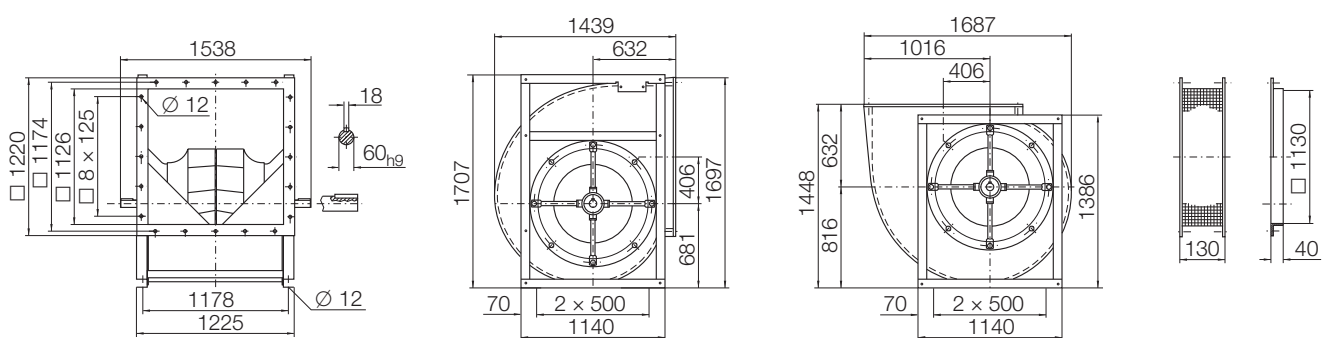

**RZR 18-0900** 409 kg **RZR 13-0900** 447 kg

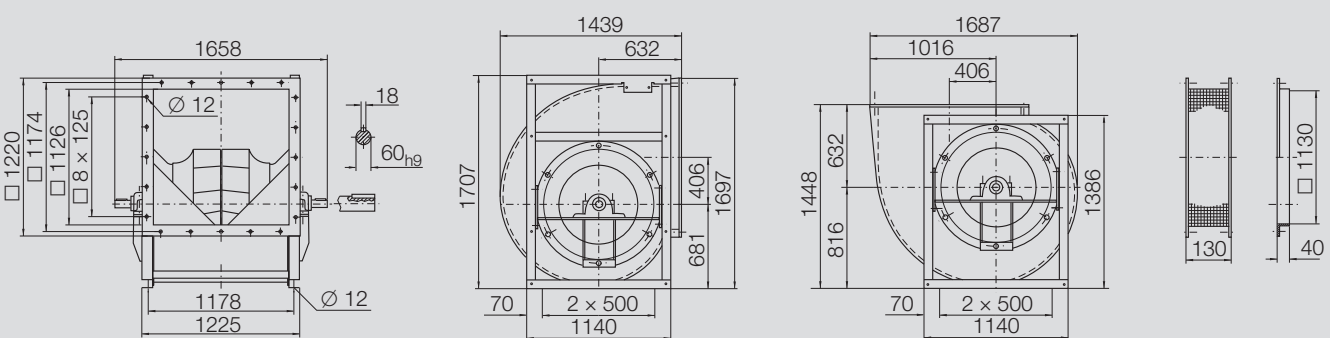

# RZR-1000

Performance certified is for installation type B - free inlet, ducted outlet.  
 Power rating (kW) does not include transmission losses.  
 Performance ratings do not include the effects of appurtenances (accessories).

## Technical Data

### Impeller Data

Impeller diameter	$D_r$	1000 mm
Number of blades	$z$	12
Moment of Inertia	$J$	22 kgm <sup>2</sup>

### Impeller Data

Impeller weight	$m$	133 kg
Density of media	$\rho_1$	1.2 kg/m <sup>3</sup>
Tolerance class (DIN 24166)		1

### Speed limits $n_{max}$ for ATEX execution

RZR 11/18	<b>650</b>	1/min
RZR 13	<b>1217</b>	1/min

## Performance Curves

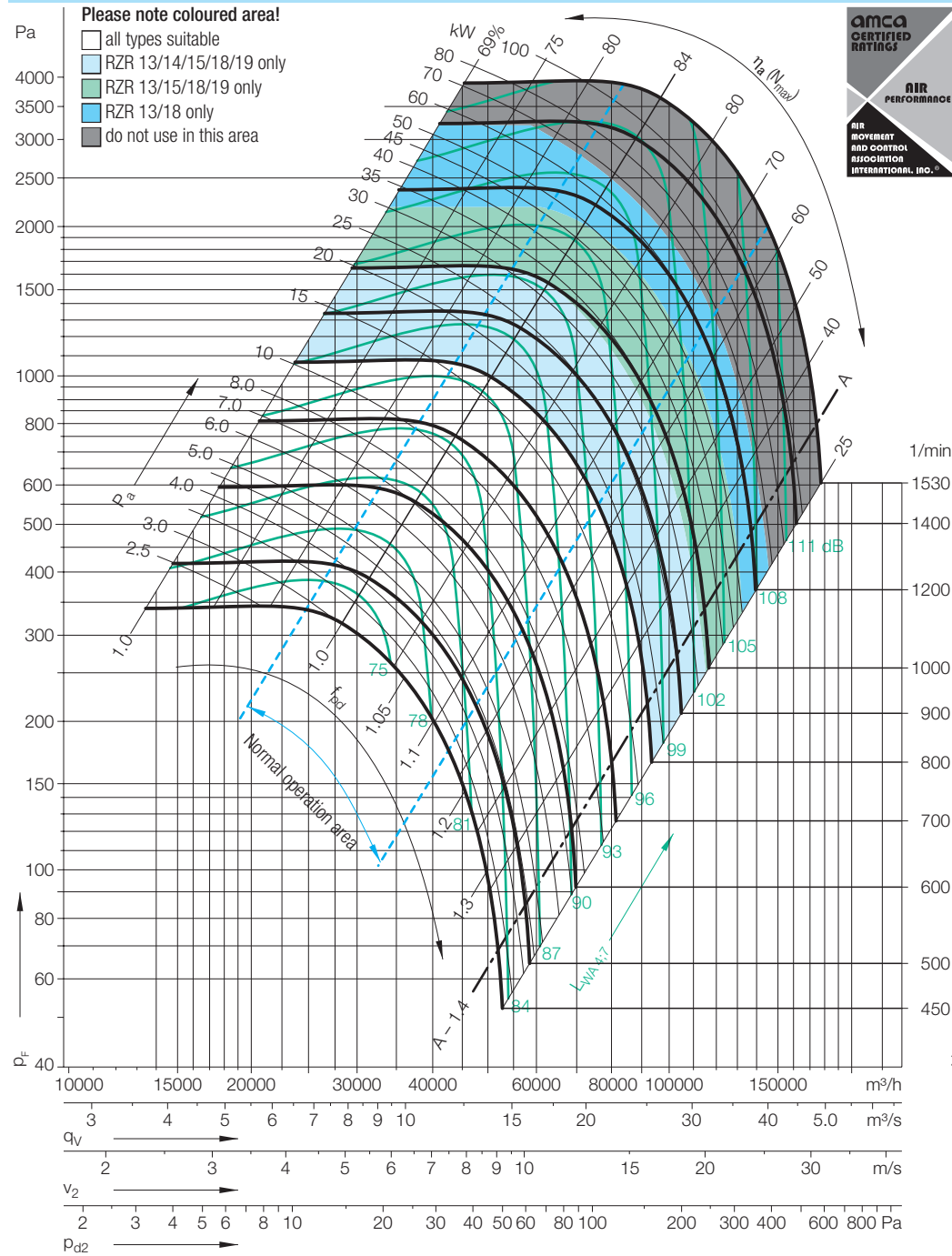

**Nicotra Gebhardt GmbH** certifies that the fan shown herein is licensed to bear the AMCA Seal. The ratings shown are based on tests and procedures performed in accordance with AMCA Publication 211 and comply with the requirements of the AMCA Certified Ratings Program. The AMCA Certified Ratings Seal applies to air performance ratings only.

Speed	Duty point
≤764 1/min	≤0.8 $q_{Vopt}$
	>0.8–1.2 $q_{Vopt}$
	>1.2–1.6 $q_{Vopt}$
	>1.6 $q_{Vopt}$
Speed	Duty point
>764 1/min	≤0.8 $q_{Vopt}$
	>0.8–1.2 $q_{Vopt}$
	>1.2–1.6 $q_{Vopt}$
	>1.6 $q_{Vopt}$

Relative sound power level for inlet side  $L_{Wrel7}$  at octave centre frequencies  $f_m$

63	125	250	500	1000	2000	4000	8000	Hz
0	2	0	-3	-6	-9	-12	-19	dB
-2	1	-2	-3	-6	-8	-14	-20	dB
-3	0	-1	-3	-6	-8	-14	-21	dB
-5	-3	-3	-3	-6	-7	-13	-21	dB
63	125	250	500	1000	2000	4000	8000	Hz
-2	-1	-3	-1	-6	-10	-15	-21	dB
-7	-4	-5	-1	-6	-9	-14	-21	dB
-10	-7	-8	-1	-5	-8	-13	-21	dB
-10	-8	-8	-2	-6	-8	-11	-18	dB

Relative sound power level for discharge side  $L_{Wrel4}$  at octave centre frequencies  $f_m$

63	125	250	500	1000	2000	4000	8000	Hz
13	7	4	-3	-8	-14	-17	-25	dB
10	5	3	-2	-7	-13	-17	-25	dB
7	2	2	-2	-6	-12	-18	-27	dB
5	1	1	-2	-6	-10	-17	-27	dB
63	125	250	500	1000	2000	4000	8000	Hz
11	4	2	0	-7	-12	-17	-24	dB
7	1	-2	-3	-6	-10	-15	-23	dB
3	-2	-4	-3	-5	-9	-14	-23	dB
2	-3	-5	-3	-5	-9	-12	-21	dB

Measured in installation B according to ISO 5801:

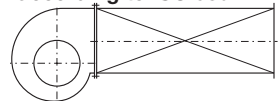

# RZR-1000

Dimensions in mm, subject to change

**RZR 11-1000** 416 kg

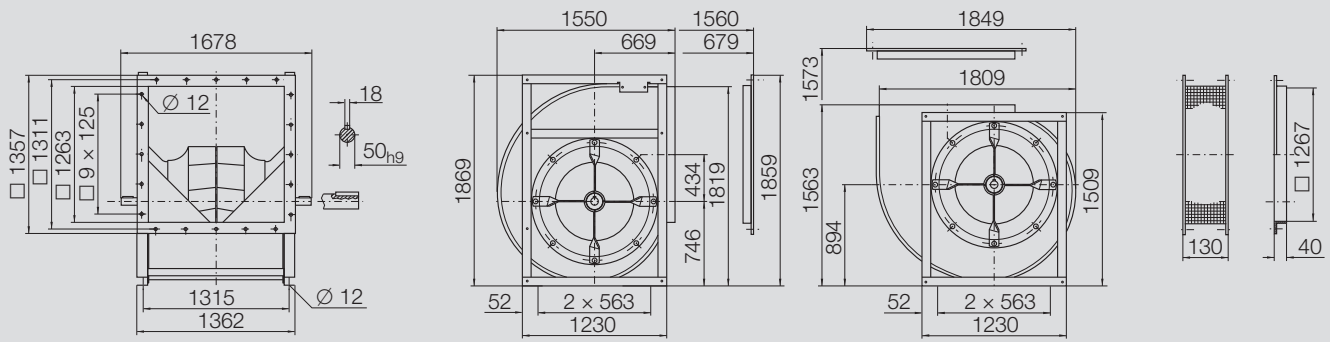

**RZR 14-1000** 435 kg

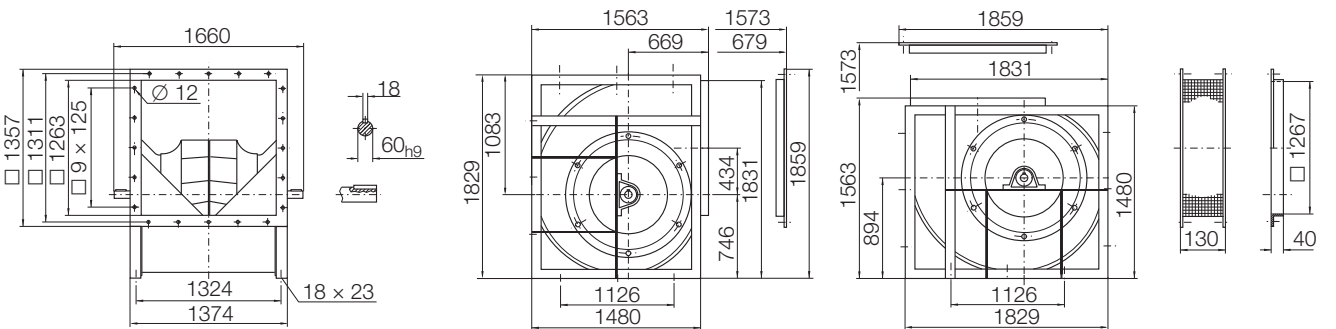

**RZR 15-1000** 416 kg

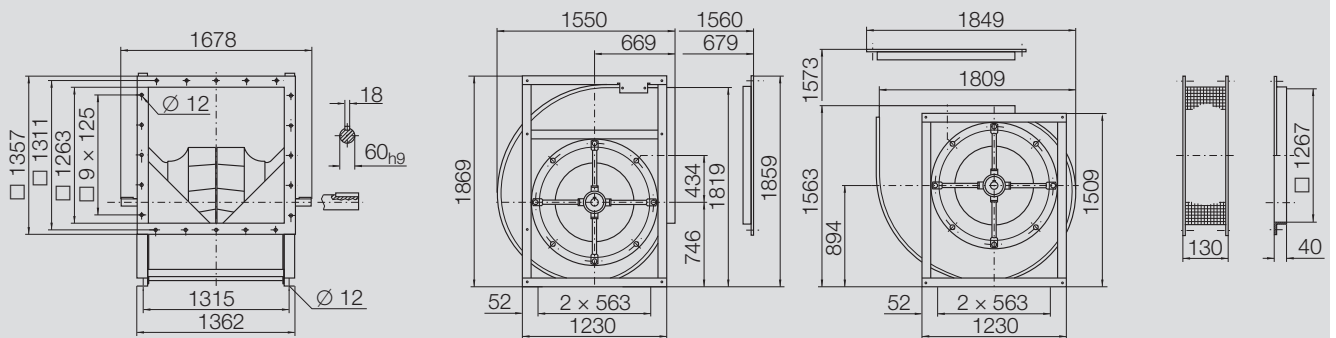

**RZR 19-1000** 462 kg

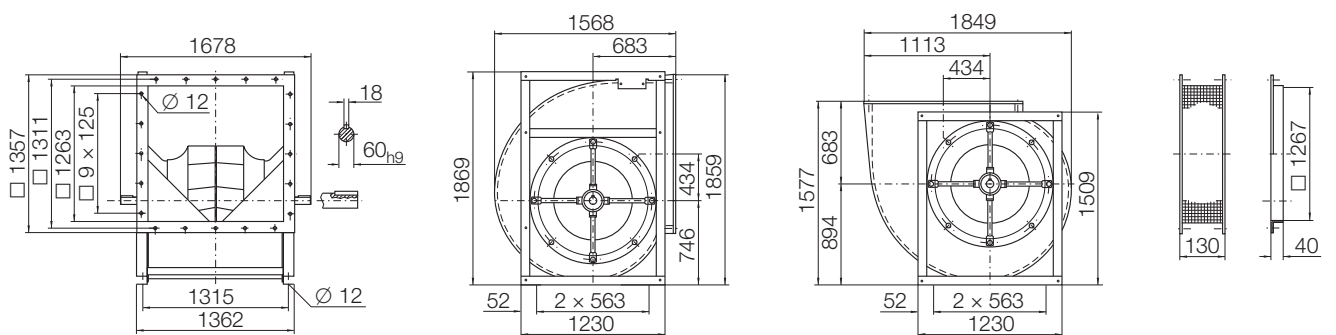

**RZR 18-1000** 471 kg **RZR 13-1000** 517 kg

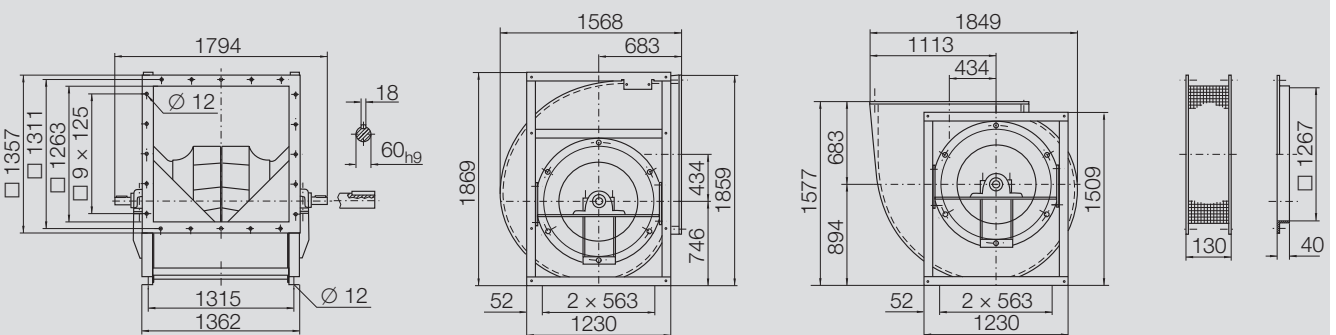

# RZR-1120

## Technical Data

### Impeller Data

Impeller diameter	$D_r$	1120 mm
Number of blades	$z$	12
Moment of Inertia	$J$	32 kgm <sup>2</sup>

### Impeller Data

Impeller weight	$m$	200 kg
Density of media	$\rho_1$	1.2 kg/m <sup>3</sup>
Tolerance class (DIN 24166)		1

### Speed limits $n_{max}$ for ATEX execution

RZR 13	<b>1026</b>	1/min
--------	-------------	-------

## Performance Curves

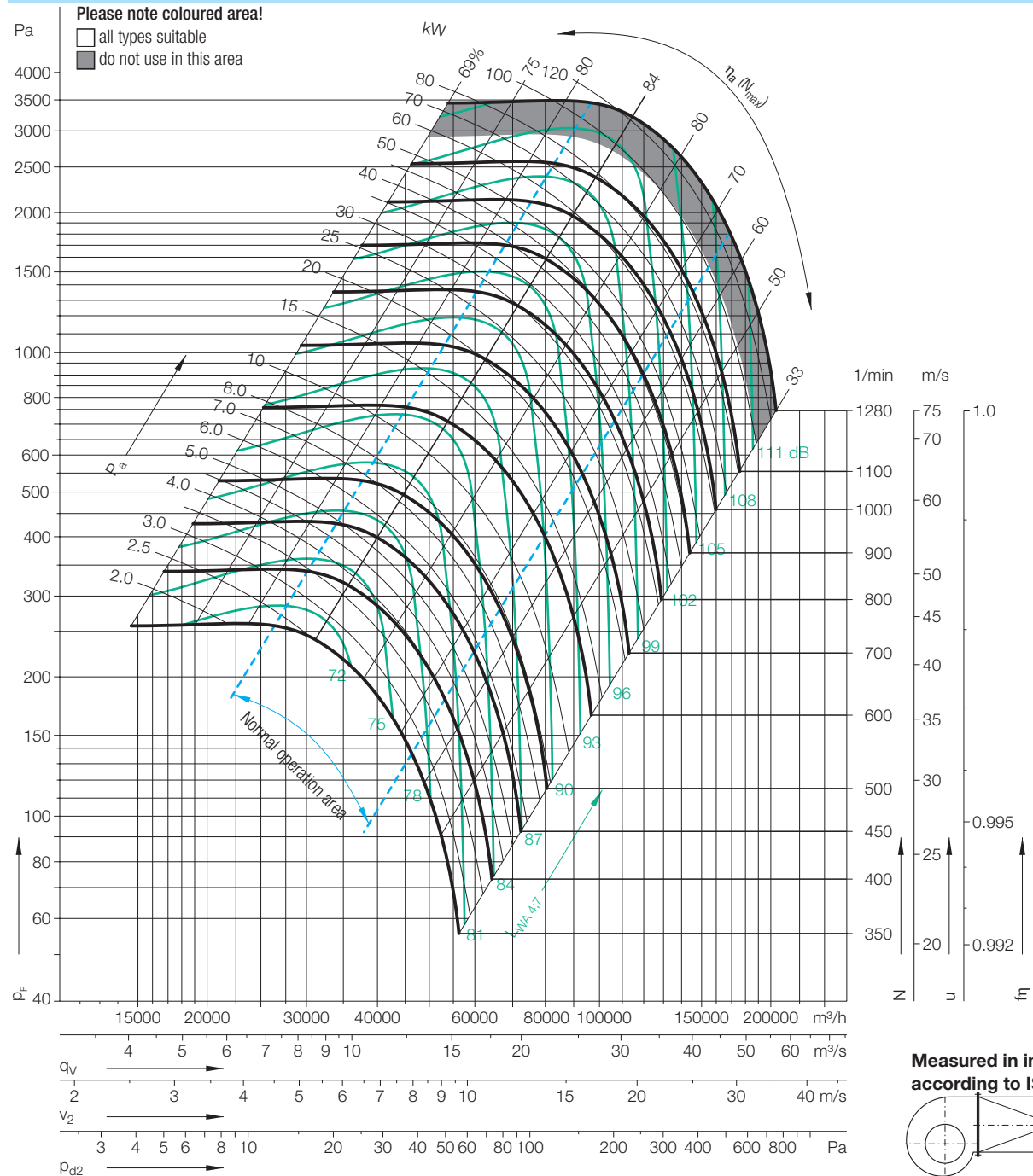

Relative sound power level for inlet side  $L_{wrel7}$  at octave centre frequencies  $f_m$

Speed	Duty point	63	125	250	500	1000	2000	4000	8000	Hz
≤682 1/min	≤0.8 $q_{Vopt}$	0	3	1	-2	-6	-9	-13	-20	dB
	>0.8–1.2 $q_{Vopt}$	-1	2	1	-2	-6	-9	-14	-21	dB
	>1.2–1.6 $q_{Vopt}$	-2	1	1	-3	-5	-8	-15	-21	dB
	>1.6–2.0 $q_{Vopt}$	-5	-3	-2	-3	-5	-7	-14	-21	dB
	>2.0 $q_{Vopt}$	-5	-3	-2	-3	-5	-7	-14	-21	dB
>682 1/min	≤0.8 $q_{Vopt}$	-1	-1	-3	-2	-7	-11	-16	-21	dB
	>0.8–1.2 $q_{Vopt}$	-6	-4	-6	-2	-7	-10	-15	-21	dB
	>1.2–1.6 $q_{Vopt}$	-10	-7	-8	-3	-6	-9	-14	-21	dB
	>1.6–2.0 $q_{Vopt}$	-10	-7	-8	-3	-6	-8	-11	-20	dB
	>2.0 $q_{Vopt}$	-10	-7	-8	-3	-6	-8	-11	-20	dB

Relative sound power level for discharge side  $L_{wrel4}$  at octave centre frequencies  $f_m$

Speed	Duty point	63	125	250	500	1000	2000	4000	8000	Hz
≤682 1/min	≤0.8 $q_{Vopt}$	12	7	4	-3	-8	-14	-18	-26	dB
	>0.8–1.2 $q_{Vopt}$	10	5	3	-3	-8	-14	-19	-28	dB
	>1.2–1.6 $q_{Vopt}$	7	2	3	-3	-6	-13	-20	-28	dB
	>1.6–2.0 $q_{Vopt}$	4	1	2	-3	-6	-12	-19	-28	dB
	>2.0 $q_{Vopt}$	4	1	2	-3	-6	-12	-19	-28	dB
>682 1/min	≤0.8 $q_{Vopt}$	10	4	1	-1	-7	-13	-18	-25	dB
	>0.8–1.2 $q_{Vopt}$	6	2	-2	-3	-6	-12	-15	-25	dB
	>1.2–1.6 $q_{Vopt}$	2	-3	-3	-3	-6	-11	-15	-25	dB
	>1.6–2.0 $q_{Vopt}$	1	-3	-5	-3	-6	-11	-13	-22	dB
	>2.0 $q_{Vopt}$	1	-3	-5	-3	-6	-11	-13	-22	dB

# RZR-1120

Dimensions in mm, subject to change  
**RZR 13-1120** 710 kg

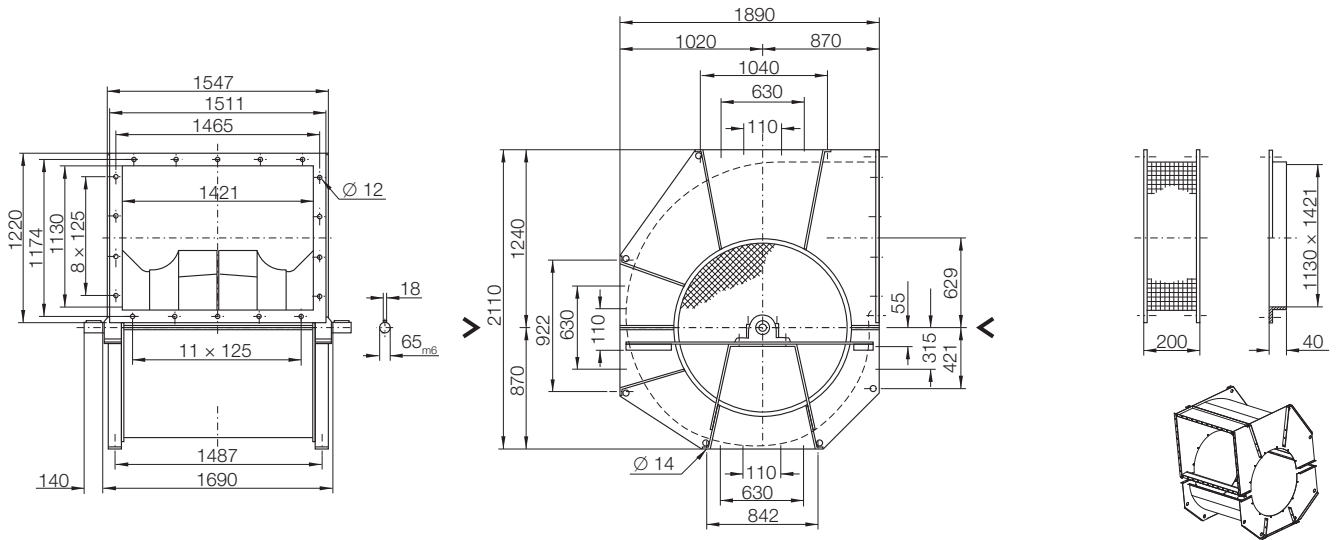

**LG 0**

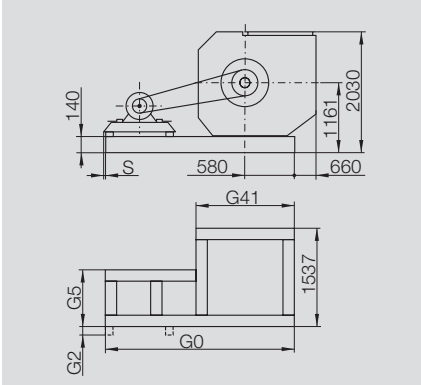

**LG 90**

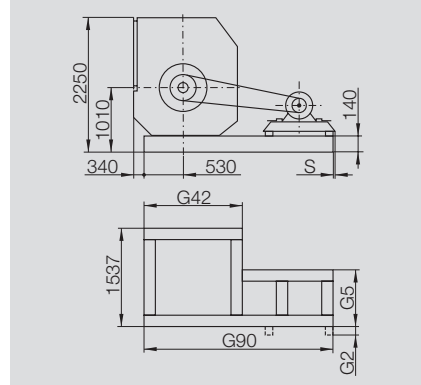

**LG 270**

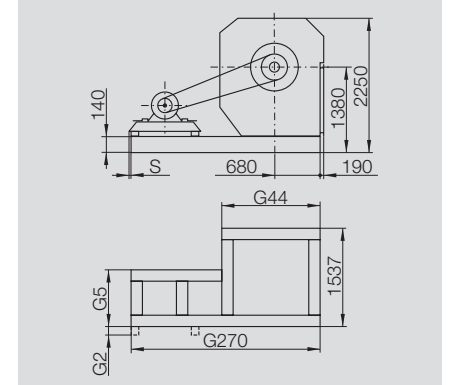

**RD 0**

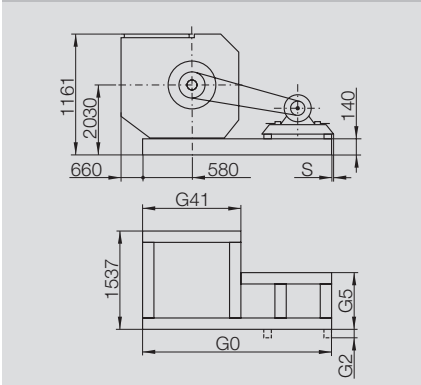

**RD 90**

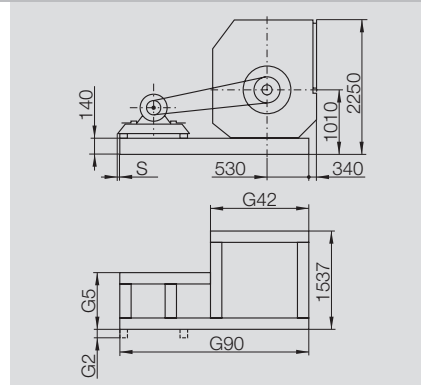

**RD 270**

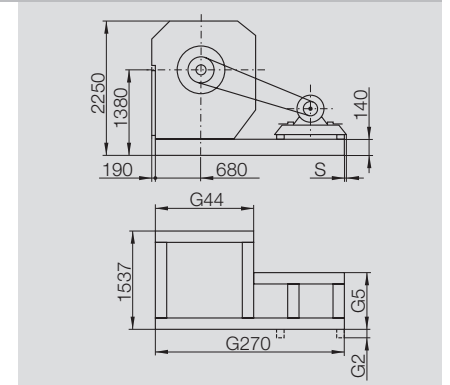

	G0	G90	G270	G41	G42	G44	G2	G5	S
<b>112</b>	1870	2040	2040	1310	1480	1480	52.5	410	-
<b>132</b>	1870	2040	2040	1310	1480	1480	52.5	410	-
<b>160</b>	2110	2210	2360	1480	1580	1730	-	410	3
<b>180</b>	2110	2210	2360	1480	1580	1730	-	410	3
<b>200</b>	2410	2480	2530	1610	1680	1730	-	510	7
<b>225</b>	2410	2480	2530	1610	1680	1730	-	510	7
<b>250</b>	2610	2680	2730	1610	1680	1730	-	660	11
<b>280</b>	2610	2680	2730	1610	1680	1730	-	660	11
<b>315</b>	2630	2680	2880	1380	1430	1630	-	760	15
<b>355</b>	2630	2680	2880	1380	1430	1630	-	760	15

# RZR-1250

## Technical Data

### Impeller Data

Impeller diameter	$D_r$	1250 mm
Number of blades	$z$	12
Moment of Inertia	$J$	62.5 kgm <sup>2</sup>

### Impeller Data

Impeller weight	$m$	263 kg
Density of media	$\rho_1$	1.2 kg/m <sup>3</sup>
Tolerance class (DIN 24166)		1

### Speed limits $n_{max}$ for ATEX execution

RZR 13	957	1/min
--------	-----	-------

## Performance Curves

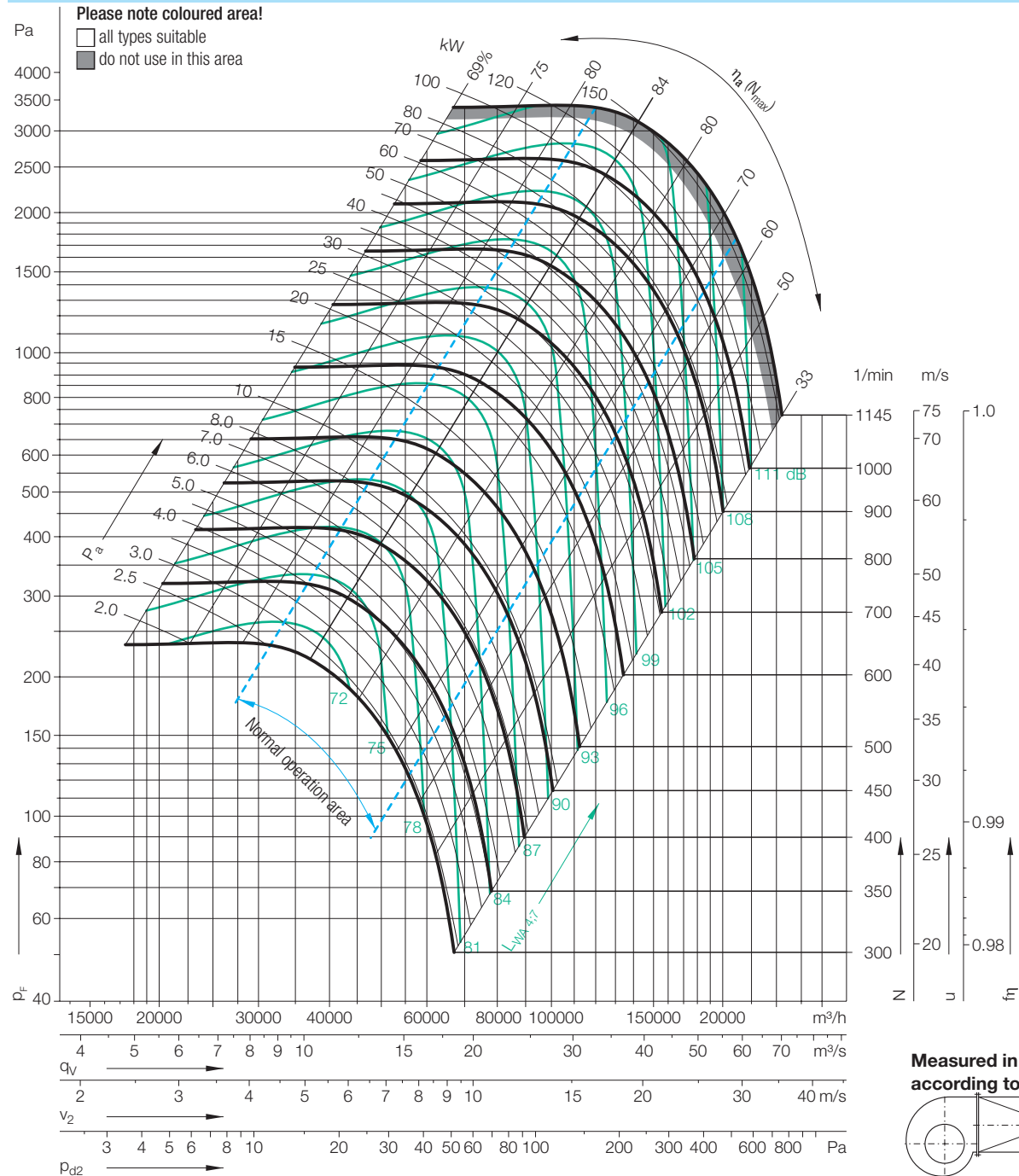

Relative sound power level for inlet side  $L_{wrel7}$  at octave centre frequencies  $f_m$

Speed	Duty point	63	125	250	500	1000	2000	4000	8000	Hz
$\leq 611$ 1/min	$\leq 0.8 q_{Vopt}$	0	3	1	-2	-6	-9	-13	-20	dB
	$> 0.8 - 1.2 q_{Vopt}$	-1	2	1	-2	-6	-9	-14	-21	dB
	$> 1.2 - 1.6 q_{Vopt}$	-2	1	1	-3	-5	-8	-15	-21	dB
	$> 1.6 - 2.0 q_{Vopt}$	-3	0	0	-3	-5	-8	-15	-21	dB
	$> 2.0 q_{Vopt}$	-5	-3	-2	-3	-5	-7	-14	-21	dB
$> 611$ 1/min	$\leq 0.8 q_{Vopt}$	-1	-1	-3	-2	-7	-11	-16	-21	dB
	$> 0.8 - 1.2 q_{Vopt}$	-6	-4	-6	-2	-7	-10	-15	-21	dB
	$> 1.2 - 1.6 q_{Vopt}$	-10	-7	-8	-3	-6	-9	-14	-21	dB
	$> 1.6 - 2.0 q_{Vopt}$	-10	-7	-8	-3	-6	-9	-14	-21	dB
	$> 2.0 q_{Vopt}$	-10	-7	-8	-3	-6	-8	-11	-20	dB

Relative sound power level for discharge side  $L_{wrel4}$  at octave centre frequencies  $f_m$

Speed	Duty point	63	125	250	500	1000	2000	4000	8000	Hz
$\leq 611$ 1/min	$\leq 0.8 q_{Vopt}$	12	7	4	-3	-8	-14	-18	-26	dB
	$> 0.8 - 1.2 q_{Vopt}$	10	5	3	-3	-8	-14	-19	-28	dB
	$> 1.2 - 1.6 q_{Vopt}$	7	2	3	-3	-6	-13	-20	-28	dB
	$> 1.6 - 2.0 q_{Vopt}$	4	1	2	-3	-6	-12	-19	-28	dB
	$> 2.0 q_{Vopt}$	4	1	2	-3	-6	-12	-19	-28	dB
$> 611$ 1/min	$\leq 0.8 q_{Vopt}$	10	4	1	-1	-7	-13	-18	-25	dB
	$> 0.8 - 1.2 q_{Vopt}$	6	2	-2	-3	-6	-12	-15	-25	dB
	$> 1.2 - 1.6 q_{Vopt}$	2	-3	-3	-3	-6	-11	-15	-25	dB
	$> 1.6 - 2.0 q_{Vopt}$	1	-3	-5	-3	-6	-11	-13	-22	dB
	$> 2.0 q_{Vopt}$	1	-3	-5	-3	-6	-11	-13	-22	dB



# RZR-1250

Dimensions in mm, subject to change  
**RZR 13-1250** 1100 kg

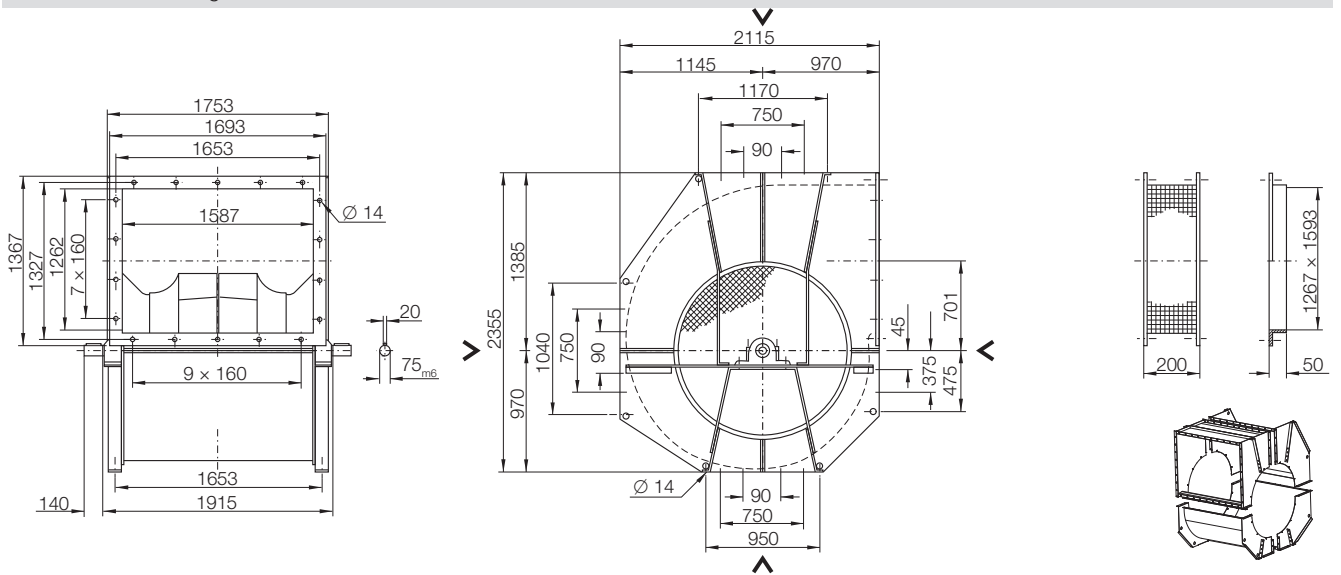

**LG 0**

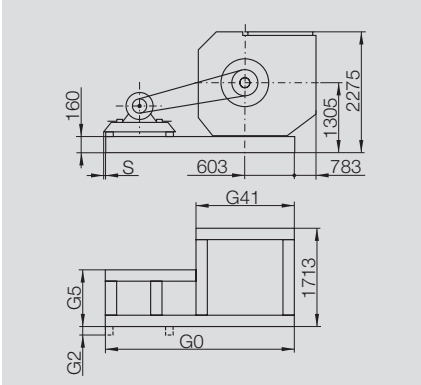

**LG 90**

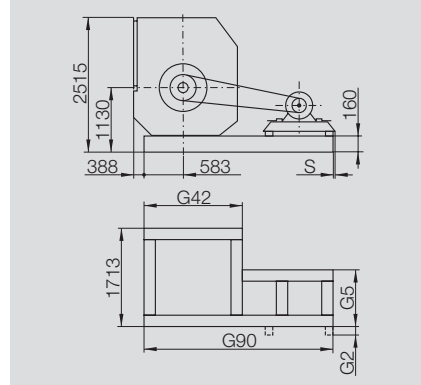

**LG 270**

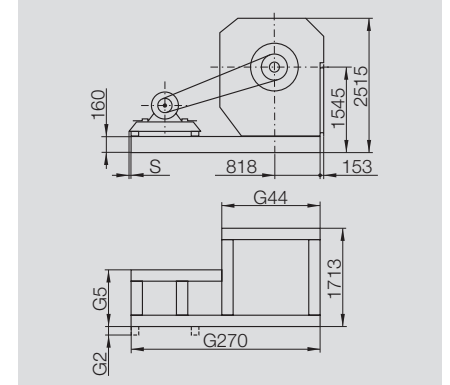

**RD 0**

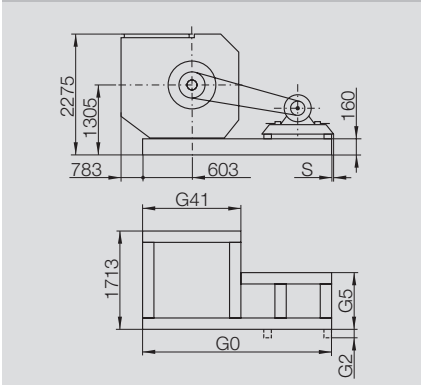

**RD 90**

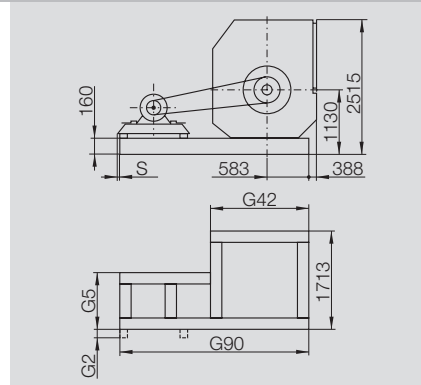

**RD 270**

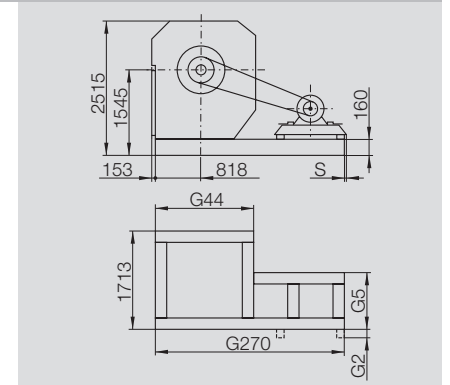

	G0	G90	G270	G41	G42	G44	G2	G5	S
<b>112</b>	1965	2220	2255	1405	1660	1695	85	450	-
<b>132</b>	1965	2220	2255	1405	1660	1695	85	450	-
<b>160</b>	2235	2390	2525	1605	1760	1895	-	415	-
<b>180</b>	2235	2390	2525	1605	1760	1895	-	415	-
<b>200</b>	2505	2660	2795	1705	1860	1995	-	515	2
<b>225</b>	2505	2660	2795	1705	1860	1995	-	515	2
<b>250</b>	2735	2860	2995	1735	1860	1995	-	665	6
<b>280</b>	2735	2860	2995	1735	1860	1995	-	665	6
<b>315</b>	2985	3160	3295	1735	1910	2045	-	1015	10
<b>355</b>	2985	3160	3295	1735	1910	2045	-	1015	10

# RZR-1400

## Technical Data

### Impeller Data

Impeller diameter	$D_r$	1400 mm
Number of blades	$z$	12
Moment of Inertia	$J$	120 kgm <sup>2</sup>

### Impeller Data

Impeller weight	$m$	335 kg
Density of media	$\rho_1$	1.2 kg/m <sup>3</sup>
Tolerance class (DIN 24166)		1

### Speed limits $n_{max}$ for ATEX execution

RZR 13	870	1/min
--------	-----	-------

## Performance Curves

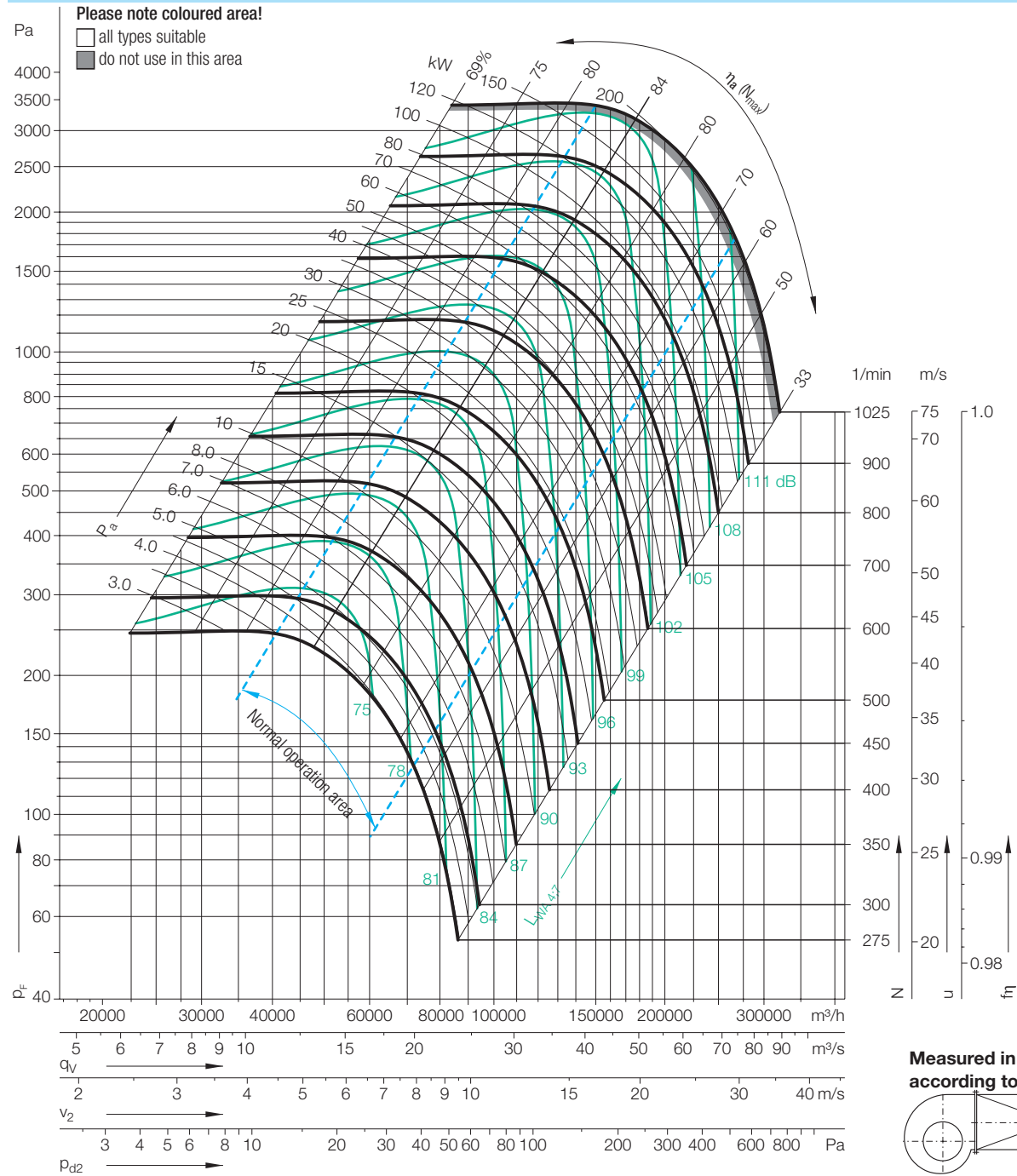

Relative sound power level for inlet side  $L_{wrel7}$  at octave centre frequencies  $f_m$

Speed	Duty point	63	125	250	500	1000	2000	4000	8000	Hz
≤546 1/min	≤0.8 $q_{Vopt}$	0	3	1	-2	-6	-9	-13	-20	dB
	>0.8–1.2 $q_{Vopt}$	-1	2	1	-2	-6	-9	-14	-21	dB
	>1.2–1.6 $q_{Vopt}$	-2	1	1	-3	-5	-8	-15	-21	dB
	>1.6–2.0 $q_{Vopt}$	-5	-3	-2	-3	-5	-7	-14	-21	dB
	>2.0 $q_{Vopt}$	-5	-3	-2	-3	-5	-7	-14	-21	dB
>546 1/min	≤0.8 $q_{Vopt}$	-1	-1	-3	-2	-7	-11	-16	-21	dB
	>0.8–1.2 $q_{Vopt}$	-6	-4	-6	-2	-7	-10	-15	-21	dB
	>1.2–1.6 $q_{Vopt}$	-10	-7	-8	-3	-6	-9	-14	-21	dB
	>1.6–2.0 $q_{Vopt}$	-10	-7	-8	-3	-6	-8	-11	-20	dB
	>2.0 $q_{Vopt}$	-10	-7	-8	-3	-6	-8	-11	-20	dB

Relative sound power level for discharge side  $L_{wrel4}$  at octave centre frequencies  $f_m$

Speed	Duty point	63	125	250	500	1000	2000	4000	8000	Hz
≤546 1/min	≤0.8 $q_{Vopt}$	12	7	4	-3	-8	-14	-18	-26	dB
	>0.8–1.2 $q_{Vopt}$	10	5	3	-3	-8	-14	-19	-28	dB
	>1.2–1.6 $q_{Vopt}$	7	2	3	-3	-6	-13	-20	-28	dB
	>1.6–2.0 $q_{Vopt}$	4	1	2	-3	-6	-12	-19	-28	dB
	>2.0 $q_{Vopt}$	4	1	2	-3	-6	-12	-19	-28	dB
>546 1/min	≤0.8 $q_{Vopt}$	10	4	1	-1	-7	-13	-18	-25	dB
	>0.8–1.2 $q_{Vopt}$	6	2	-2	-3	-6	-12	-15	-25	dB
	>1.2–1.6 $q_{Vopt}$	2	-3	-3	-3	-6	-11	-15	-25	dB
	>1.6–2.0 $q_{Vopt}$	1	-3	-5	-3	-6	-11	-13	-22	dB
	>2.0 $q_{Vopt}$	1	-3	-5	-3	-6	-11	-13	-22	dB

# RZR-1400

**Dimensions** in mm, subject to change  
**RZR 13-1400** 1390 kg

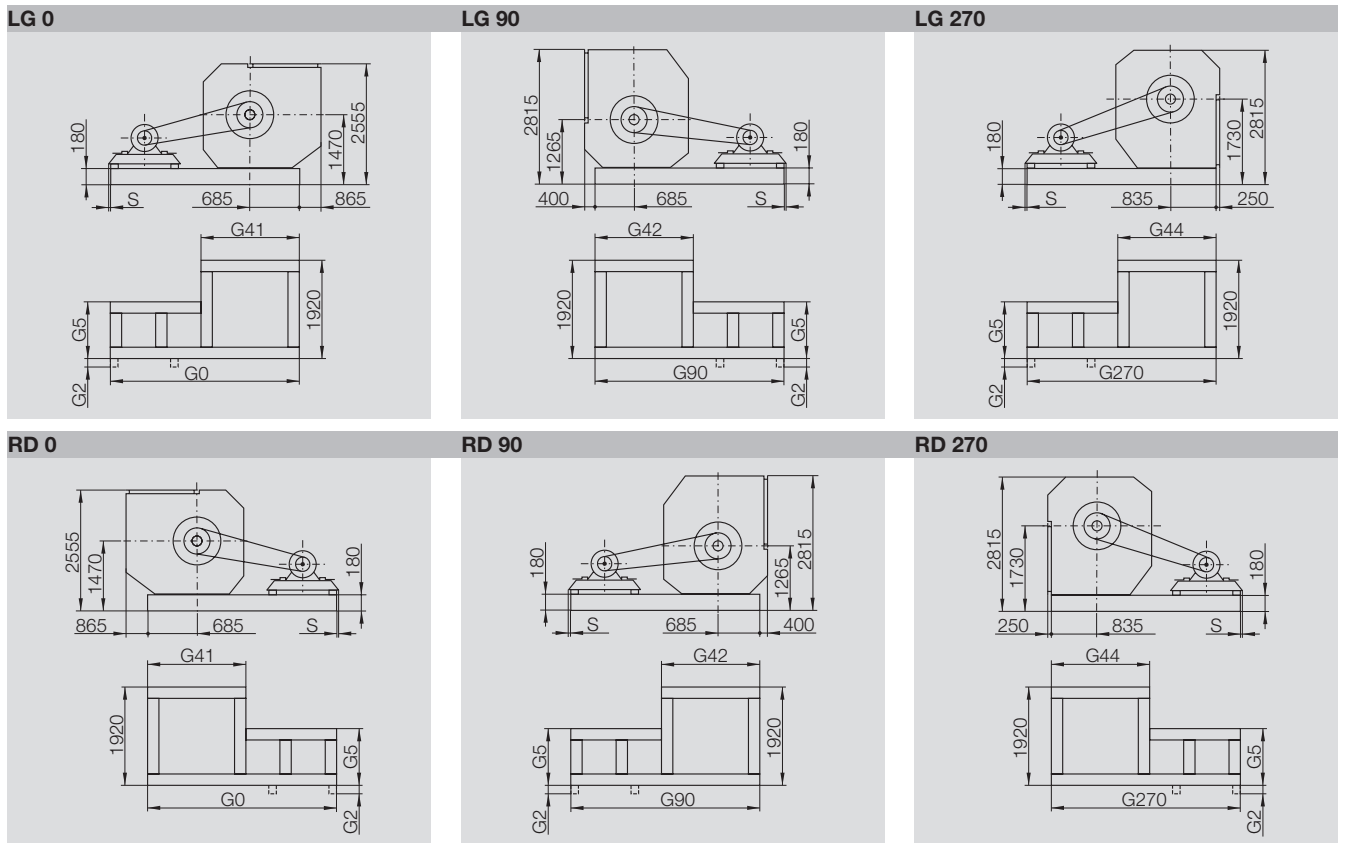
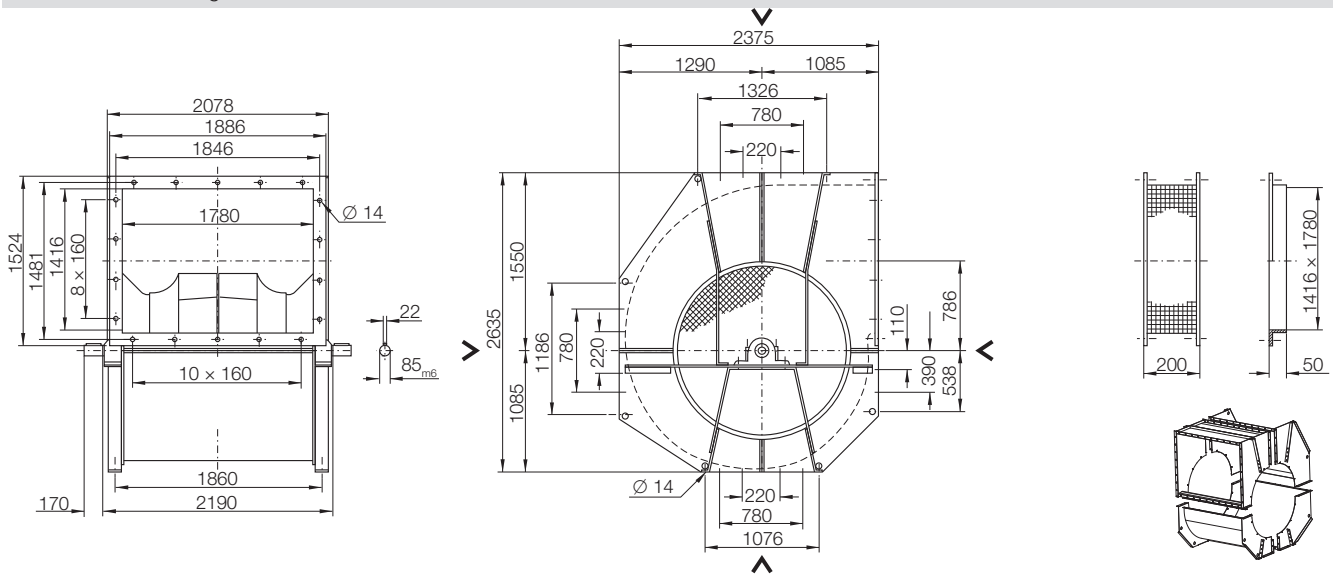

	G0	G90	G270	G41	G42	G44	G2	G5	S
<b>160</b>	2225	2550	2580	1505	1830	1860	87	420	-
<b>180</b>	2225	2550	2580	1505	1830	1860	87	420	-
<b>200</b>	2495	2800	2950	1605	1910	2060	62	470	-
<b>225</b>	2495	2800	2950	1605	1910	2060	62	470	-
<b>250</b>	2775	2960	3160	1775	1960	2160	-	670	6
<b>280</b>	2775	2960	3160	1775	1960	2160	-	670	6
<b>315</b>	3055	3230	3410	1805	1980	2160	-	1020	10
<b>355</b>	3055	3230	3410	1805	1980	2160	-	1020	10

# RZR-1600

## Technical Data

### Impeller Data

Impeller diameter	$D_r$	1600 mm
Number of blades	$z$	12
Moment of Inertia	$J$	186 kgm <sup>2</sup>

### Impeller Data

Impeller weight	$m$	486 kg
Density of media	$\rho_1$	1.2 kg/m <sup>3</sup>
Tolerance class (DIN 24166)		1

### Speed limits $n_{max}$ for ATEX execution

RZR 13	748	1/min
--------	-----	-------

## Performance Curves

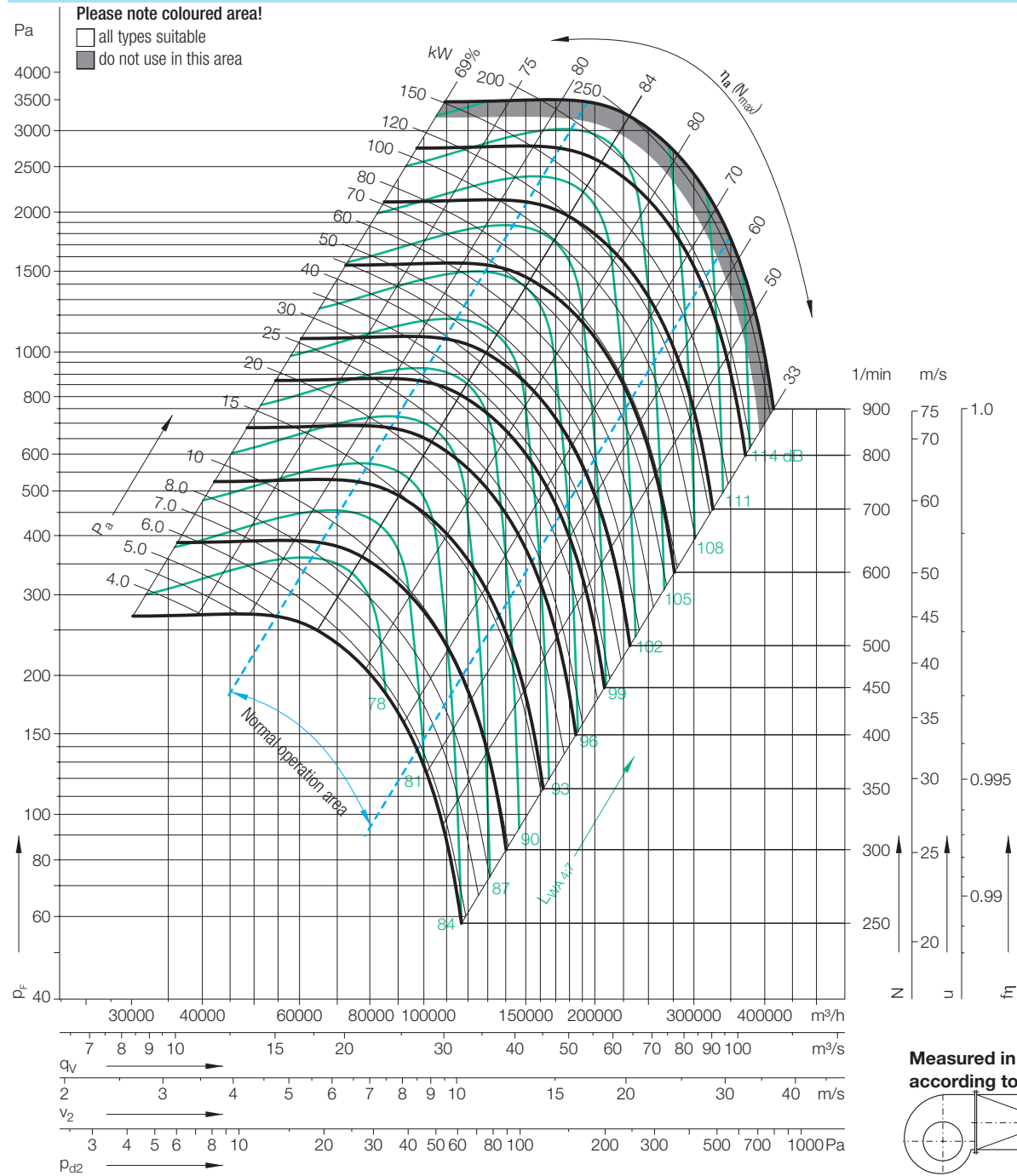

Relative sound power level for inlet side  $L_{wrel7}$  at octave centre frequencies  $f_m$

Speed	Duty point	63	125	250	500	1000	2000	4000	8000	Hz
≤478 1/min	≤0.8 $q_{Vopt}$	0	3	1	-2	-6	-9	-13	-20	dB
	>0.8–1.2 $q_{Vopt}$	-1	2	1	-2	-6	-9	-14	-21	dB
	>1.2–1.6 $q_{Vopt}$	-2	1	1	-3	-5	-8	-15	-21	dB
	>1.6–2.0 $q_{Vopt}$	-3	0	0	-4	-6	-9	-16	-22	dB
	>2.0 $q_{Vopt}$	-5	-3	-2	-3	-5	-7	-14	-21	dB
>478 1/min	≤0.8 $q_{Vopt}$	-1	-1	-3	-2	-7	-11	-16	-21	dB
	>0.8–1.2 $q_{Vopt}$	-6	-4	-6	-2	-7	-10	-15	-21	dB
	>1.2–1.6 $q_{Vopt}$	-10	-7	-8	-3	-6	-9	-14	-21	dB
	>1.6–2.0 $q_{Vopt}$	-10	-7	-8	-3	-6	-9	-14	-21	dB
	>2.0 $q_{Vopt}$	-10	-7	-8	-3	-6	-8	-11	-20	dB

Relative sound power level for discharge side  $L_{wrel4}$  at octave centre frequencies  $f_m$

Speed	Duty point	63	125	250	500	1000	2000	4000	8000	Hz
≤478 1/min	≤0.8 $q_{Vopt}$	12	7	4	-3	-8	-14	-18	-26	dB
	>0.8–1.2 $q_{Vopt}$	10	5	3	-3	-8	-14	-19	-28	dB
	>1.2–1.6 $q_{Vopt}$	7	2	3	-3	-6	-13	-20	-28	dB
	>1.6–2.0 $q_{Vopt}$	4	1	2	-3	-6	-12	-19	-28	dB
	>2.0 $q_{Vopt}$	4	1	2	-3	-6	-12	-19	-28	dB
>478 1/min	≤0.8 $q_{Vopt}$	10	4	1	-1	-7	-13	-18	-25	dB
	>0.8–1.2 $q_{Vopt}$	6	2	-2	-3	-6	-12	-15	-25	dB
	>1.2–1.6 $q_{Vopt}$	2	-3	-3	-3	-6	-11	-15	-25	dB
	>1.6–2.0 $q_{Vopt}$	1	-3	-3	-3	-6	-11	-13	-22	dB
	>2.0 $q_{Vopt}$	1	-3	-5	-3	-6	-11	-13	-22	dB

# RZR-1600

**Dimensions** in mm, subject to change  
**RZR 13-1600** 1870 kg

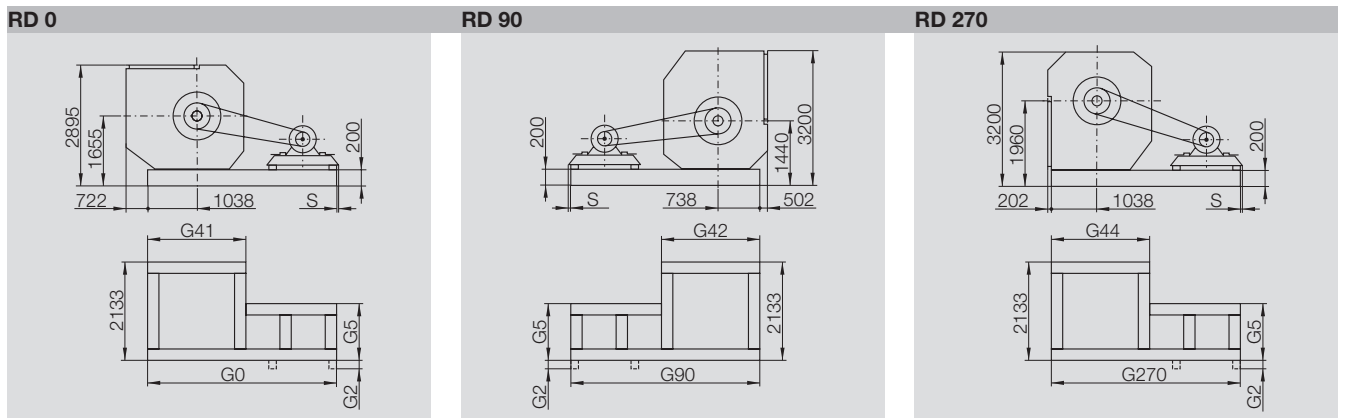
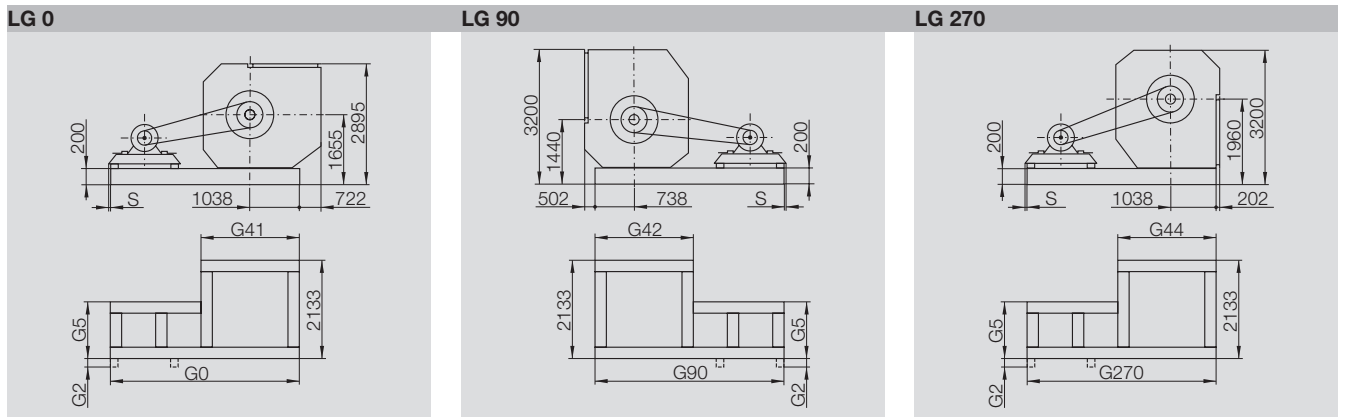
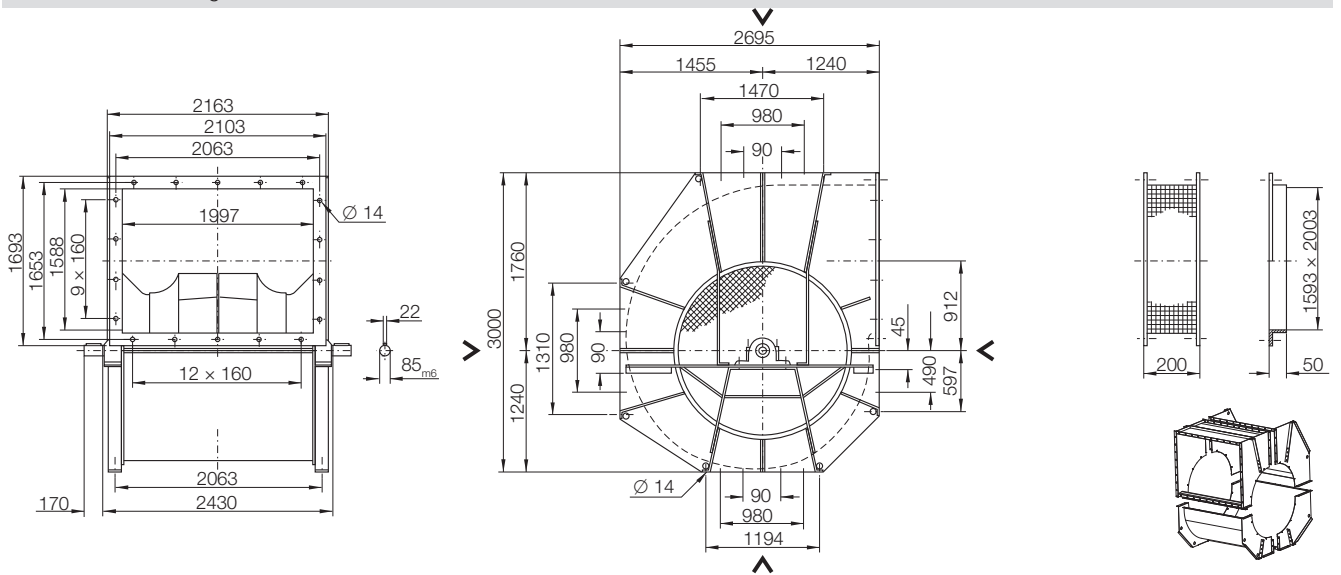

	G0	G90	G270	G41	G42	G44	G2	G5	S
<b>160</b>	2736	2786	2901	2016	2066	2181	105.0	425	-
<b>180</b>	2736	2786	2901	2016	2066	2181	105.0	425	-
<b>200</b>	3066	3016	3231	2166	2116	2331	75.5	425	-
<b>225</b>	3066	3016	3231	2166	2116	2331	75.5	425	-
<b>250</b>	3316	3166	3481	2316	2166	2481	-	675	1
<b>280</b>	3316	3166	3481	2316	2166	2481	-	675	1
<b>315</b>	3804	3704	4019	2316	2216	2531	-	1154	57
<b>355</b>	3804	3704	4019	2316	2216	2531	-	1154	57

# RZR 11-0200/-1000

## Specifications

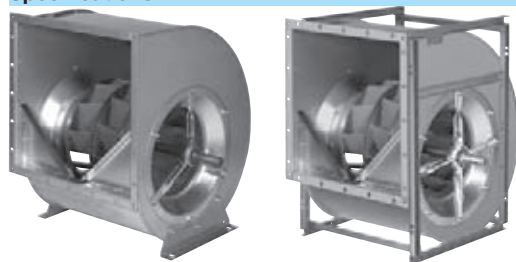

### High performance centrifugal fan *rotavent* RZR 11

double inlet belt drive.  
 Lap jointed scroll of galvanised sheet steel with discharge flange and bolt on multi-position feet (Size 0200/-0710), with heavy duty side frames (Size 0800/-1000).  
 High performance impeller with 12 hollow section true airfoil blades (Size 0315/-1000), with 11 backward curved laminar blades (Size 0200/-0280) inclined obliquely to the shaft axis, welded in position and epoxy coated.  
 Throat plate inclined obliquely in opposition to blade inclination.  
 Inlet cones matched to the impeller reduce entry losses to a minimum.  
 Impeller and shaft balanced as an assembly in according to DIN ISO 1940.  
 Noise tested maintenance free, radial insert ball bearings mounted in pressed steel housing/strut assemblies with rubber interliners.  
 As an option – relubricatable in operation within cast iron housings, supported from the fan casing by tubular struts (0200/-1000).  
 Performance data to DIN 24166 Class 1 / BS 848 Class "A" (Size 0315/-1000) or Class 2 / BS 848 Class "B" (Size 0200/-0280).

## Fan data

<b>Fan type</b>	.....	
<b>Volume flow</b>	$Q_v$ .....	m <sup>3</sup> /h
<b>Total pressure increase</b>	$p_F$ .....	Pa
<b>Static pressure</b>	$p_{sF}$ .....	Pa
<b>Air density at fan inlet</b>	$\rho_1$ .....	kg/m <sup>3</sup>
<b>Air medium temperature</b>	$t$ .....	°C
<b>Shaft power</b>	$P_a$ .....	kW
<b>Efficiency</b>	$(\eta_a)$ .....	
<b>Speed</b>	$N$ .....	1/min
<b>Sound power level (A weighted)</b>	$L_{WA}$ .....	dB
<b>Weight</b>	$m$ .....	kg

## Fittings / Accessories

- Drain plug R1/2" (B.S.P. 1/2")
- Access door
- Special coating Class S40, K90 or P100
- Centrifugal fan in Ex-Execution in Acc. to ATEX
- Impeller blades continuously welded
- Shaft made of stainless steel (1.4305)
- Nuts and bolts of stainless steel (1.4305)
- Volumeter IMV13
- Copper inlet cone
- Relubrication in Operation (0200/-0710) IWN01 or IWN11
- 
- Inlet Guards
- Discharge Guard
- Shaft guard
- Discharge Flange
- Discharge Flex (with flexible sleeve)
- Base frame with integrated strain-sledge (0200/-0500)
- Base frame with motor rails (0400/-1000)
- Pick-a-Back (for attaching motor fan)
- Belt drive, V-belt or flat Belt
- Belt guard
- Belt guard split horizontally
- Motor
- Anti-vibration mounts

# RZR 12-0200/-0710

## Specifications

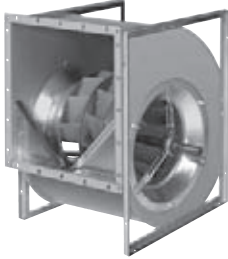

### High performance centrifugal fan *rotavent* RZR 12

double inlet belt drive.  
 Lap jointed scroll of galvanised sheet steel with discharge flange and rectangular, angle side frames.  
 High performance impeller with 12 hollow section true airfoil blades (Size 0315/-0710, with 11 backward curved laminar blades (Size 0200/-0280) inclined obliquely to the shaft axis, welded in position and epoxy coated.  
 Throat plate inclined obliquely in opposition to blade inclination.  
 Inlet cones matched to the impeller reduce entry losses to a minimum.  
 Impeller and shaft balanced as an assembly in according to DIN ISO 1940.  
 Noise tested maintenance free, radial insert ball bearings mounted in pressed steel housing/strut assemblies with rubber interliners. As an option – relubricatable in operation within cast iron housings, supported from the fan casing by tubular struts.  
 Performance data to DIN 24166 Class 1 / BS 848 Class "A" (Size 0315/-0710) or Class 2 / BS 848 Class "B" (Size 0200/-0280).

## Fan data

<b>Fan type</b>	.....	
<b>Volume flow</b>	$Q_V$ .....	m <sup>3</sup> /h
<b>Total pressure increase</b>	$p_F$ .....	Pa
<b>Static pressure</b>	$p_{SF}$ .....	Pa
<b>Air density at fan inlet</b>	$\rho_1$ .....	kg/m <sup>3</sup>
<b>Air medium temperature</b>	$t$ .....	°C
<b>Shaft power</b>	$P_a$ .....	kW
<b>Efficiency</b>	$(\eta_a)$ .....	
<b>Speed</b>	$N$ .....	1/min
<b>Sound power level (A weighted)</b>	$L_{WA}$ .....	dB
<b>Weight</b>	$m$ .....	kg

## Fittings / Accessories

- Drain plug R1/2" (B.S.P. 1/2")
- Access door
- Special coating Class S40, K90 or P100
- Centrifugal fan in Ex-Execution in Acc. to ATEX
- Impeller blades continuously welded
- Shaft made of stainless steel (1.4305)
- Nuts and bolts of stainless steel (1.4305)
- Volumeter IMV13
- Copper inlet cone
- Relubrication in Operation IWN01 or IWN11
- 
- Inlet Guards
- Discharge Guard
- Shaft guard
- Discharge Flange
- Discharge Flex (with flexible sleeve)
- Base frame with motor rails
- Pick-a-Back (for attaching motor fan)
- Belt drive, V-belt or flat Belt
- Belt guard
- Belt guard split horizontally
- Motor
- Anti-vibration mounts

# RZR 14-0315/-1000

## Specifications

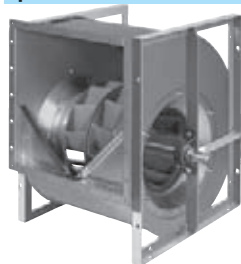

### High performance Centrifugal fan Gebhardt rotavent RZR 14

Double inlet belt drive. Lockformed scroll casing made of galvanised steel sheet, with connecting flange at discharge. Welded heavy duty reinforced side frames, coated. High performance impeller with 12 hollow section true airfoil blades inclined obliquely to the shaft axis, welded in position and painted. Throat plate inclined obliquely in opposition to blade inclination. Inlet cones matched to the impeller reduce entry losses to a minimum. Impeller and shaft balanced as an assembly in accordance to DIN ISO 1940.

Monobloc pedestal cast iron bearings with relubrication nipple, mounted on a robust pedestal, integrated, self aligning radial insert ball bearings fixed by eccentric tightening clamp.

Performance data to DIN 24 166 Class1 / BS 848 Class "A".

## Fan data

Fan type	.....	
Volume flow	$Q_v$ .....	m <sup>3</sup> /h
Total pressure increase	$p_F$ .....	Pa
Static pressure	$p_{sF}$ .....	Pa
Air density at fan inlet	$\rho_1$ .....	kg/m <sup>3</sup>
Air medium temperature	$t$ .....	°C
Shaft power	$P_a$ .....	kW
Efficiency	$(\eta_a)$ .....	
Speed	$N$ .....	1/min
Sound power level (A weighted)	$L_{WA}$ .....	dB
Weight	$m$ .....	kg

## Fittings / Accessories

- Drain plug R1/2" (B.S.P. 1/2")
- Access door
- Special coating Class S40, K90 or P100
- Impeller blades continuously welded
- Shaft made of stainless steel (1.4305)
- Nuts and bolts of stainless steel (1.4305)
- Volumeter IMV13
- Copper inlet cone
- Relubrication in operation IWN01
  
- Inlet Guards
- Discharge Guard
- Shaft guard
- Discharge Flange
- Discharge Flex (with flexible sleeve)
- Base frame with motor rails
- Pick-a-Back (for attaching motor fan)
- Belt drive, V-belt or flat Belt
- Belt guard
- Belt guard split horizontally
- Motor
- Anti-vibration mounts



# RZR 15-0400/-1000

## Specifications

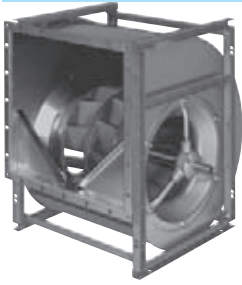

### High performance centrifugal fan *rotavent* RZR 15

double inlet belt drive.  
 Lap jointed scroll of galvanised sheet steel with discharge flange and heavy duty reinforced side frames.  
 High performance impeller with 12 hollow section true airfoil blades inclined obliquely to the shaft axis, welded in position and epoxy coated.  
 Throat plate inclined obliquely in opposition to bladeinclination.  
 Inlet cones matched to the impeller reduce entrylosses to a minimum.  
 Impeller and shaft balanced as an assembly in according to DIN ISO 1940.  
 Self aligning double row ball bearings secured by adapter sleeve, mounted within a cast iron housing packed with long life, high performance grease. Can be relubricated when not in service.  
 Performance data to DIN 24166 Class 1 / BS 848 Class "A".

## Fan data

Fan type	.....	
Volume flow	$Q_V$ .....	m <sup>3</sup> /h
Total pressure increase	$p_F$ .....	Pa
Static pressure	$p_{SF}$ .....	Pa
Air density at fan inlet	$\rho_1$ .....	kg/m <sup>3</sup>
Air medium temperature	$t$ .....	°C
Shaft power	$P_a$ .....	kW
Efficiency	$(\eta_a)$ .....	
Speed	$N$ .....	1/min
Sound power level (A weighted)	$L_{WA}$ .....	dB
Weight	$m$ .....	kg

## Fittings / Accessories

- Drain plug R1/2" (B.S.P. 1/2")
- Access door
- Special coating Class S40, K90 or P100
- Impeller blades continuously welded
- Shaft made of stainless steel (1.4305)
- Nuts and bolts of stainless steel (1.4305)
- Tapped hole for measurement of shock impulse
- Inlet vane controller IVC
- Manual IVC-operating lever
- Volumeter IMV13
- Copper inlet cone
- Relubrication in operation IWN01 or IWN11
- 
- Inlet Guards
- Discharge Guard
- Shaft guard
- Discharge Flange
- Discharge Flex (with flexible sleeve)
- Base frame with motor rails
- Pick-a-Back (for attaching motor fan)
- Belt drive, V-belt or flat Belt
- Belt guard
- Belt guard split horizontally
- Motor
- Anti-vibration mounts

# RZR 18-0400/-1000

## Specifications



### High performance centrifugal fan *rotavent* RZR 18

double inlet belt drive.  
 Lap jointed scroll of galvanised sheet steel with discharge flange and heavy duty reinforced side frames.  
 High performance impeller with 12 hollow section true airfoil blades inclined obliquely to the shaft axis, welded in position and epoxy coated.  
 Throat plate inclined obliquely in opposition to blade inclination.  
 Inlet cones matched to the impeller reduce entry losses to a minimum.  
 Impeller and shaft balanced as an assembly in according to DIN ISO 1940.  
 Self aligning double row ball bearings within standard plummer blocks, mounted on robust pedestal, packed with long life, high performance grease. Can be relubricated when not in service.  
 Performance data to DIN 24166 Class 1 / BS 848 Class "A".

## Fan data

<b>Fan type</b>	.....	
<b>Volume flow</b>	$Q_v$ .....	m <sup>3</sup> /h
<b>Total pressure increase</b>	$p_F$ .....	Pa
<b>Static pressure</b>	$p_{sF}$ .....	Pa
<b>Air density at fan inlet</b>	$\rho_1$ .....	kg/m <sup>3</sup>
<b>Air medium temperature</b>	$t$ .....	°C
<b>Shaft power</b>	$P_a$ .....	kW
<b>Efficiency</b>	$(\eta_a)$ .....	
<b>Speed</b>	$N$ .....	1/min
<b>Sound power level (A weighted)</b>	$L_{WA}$ .....	dB
<b>Weight</b>	$m$ .....	kg

## Fittings / Accessories

- Drain plug R1/2" (B.S.P. 1/2")
- Access door
- Special coating Class S40, K90 or P100
- Centrifugal fan in Ex-Execution in Acc. to ATEX
- Impeller blades continuously welded
- Shaft made of stainless steel (1.4305)
- Nuts and bolts of stainless steel (1.4305)
- Tapped hole for measurement of shock impulse
- Inlet vane controller IVC
- Manual IVC-operating lever
- Volumeter IMV13
- Copper inlet cone
- Relubrication in operation IWN01 or IWN11
  
- Inlet Guards
- Discharge Guard
- Shaft guard
- Discharge Flange
- Discharge Flex (with flexible sleeve)
- Base frame with motor rails
- Pick-a-Back (for attaching motor fan)
- Belt drive, V-belt or flat Belt
- Belt guard
- Belt guard split horizontally
- Motor
- Anti-vibration mounts

# RZR 19-0200/-0355

## Specifications



### High performance centrifugal fan *rotavent* RZR 19-0200/-0355

double inlet belt drive.  
 Scroll casing stitch welded with discharge flange and bolt on multi-position feet.  
 High performance impeller with 12 hollow section true airfoil blades (Size 0315/-0355), with 11 backward curved laminar blades (Size 0200/-0280) inclined obliquely to the shaft axis, welded in position and epoxy coated.  
 Throat plate inclined obliquely in opposition to blade inclination.  
 Inlet cones matched to the impeller reduce entry losses to a minimum.  
 Impeller and shaft balanced as an assembly in according to DIN ISO 1940.  
 Noise tested, maintenance free, radial insert ball bearings with spherical outer ring mounted within castiron housings, supported from the fan casing by tubular struts.  
 Performance data to DIN 24166 Class 1 / BS 848 Class "A" (Size 0315/-0355) or Class 2 / BS 848 Class "B" (Size 0200/-0280).

## Fan data

Fan type	.....	
Volume flow	$Q_V$ .....	m <sup>3</sup> /h
Total pressure increase	$p_F$ .....	Pa
Static pressure	$p_{SF}$ .....	Pa
Air density at fan inlet	$\rho_1$ .....	kg/m <sup>3</sup>
Air medium temperature	$t$ .....	°C
Shaft power	$P_a$ .....	kW
Efficiency	$(\eta_a)$ .....	
Speed	$N$ .....	1/min
Sound power level (A weighted)	$L_{WA}$ .....	dB
Weight	$m$ .....	kg

## Fittings / Accessories

- Drain plug R1/2" (B.S.P. 1/2")
- Access door
- Special coating Class K90 or P100
- Centrifugal fan in Ex-Execution in Acc. to ATEX
- Impeller blades continuously welded
- Casing continuously welded inside
- Casing continuously welded inside and outside
- Shaft made of stainless steel (1.4305)
- Nuts and bolts of stainless steel (1.4305)
- Volumeter IMV13
- Copper inlet cone
- Relubrication in operation IWN01 or IWN11
  
- Inlet Guards
- Discharge Guard
- Shaft guard
- Discharge Flange
- Discharge Flex (with flexible sleeve)
- Base frame with integrated motor strain-sledge
- Pick-a-Back (for attaching motor fan)
- Belt drive, V-belt or flat Belt
- Belt guard
- Belt guard split horizontally
- Motor
- Anti-vibration mounts

# RZR 19-0400/-1000

## Specifications



### High performance centrifugal fan *rotavent* RZR 19-0400/-1000

double inlet belt drive.  
 Scroll casing stitch welded with discharge flange, and heavy duty reinforced side frames, epoxy coated.  
 High performance impeller with 12 hollow section true airfoil blades inclined obliquely to the shaft axis, welded in position and epoxy coated.  
 Throat plate inclined obliquely in opposition to blade inclination.  
 Inlet cones matched to the impeller reduce entry losses to a minimum.  
 Impeller and shaft balanced as an assembly in accordance to DIN ISO 1940.  
 Self aligning double row ball bearings secured by adapter sleeve, mounted within a cast iron housing packed with long life, high performance grease. Can be relubricated when not in service.  
 Performance data to DIN 24166 Class 1 / BS 848 Class "A".

## Fan data

<b>Fan type</b>	.....	
<b>Volume flow</b>	$Q_v$ .....	m <sup>3</sup> /h
<b>Total pressure increase</b>	$p_F$ .....	Pa
<b>Static pressure</b>	$p_{sF}$ .....	Pa
<b>Air density at fan inlet</b>	$\rho_1$ .....	kg/m <sup>3</sup>
<b>Air medium temperature</b>	$t$ .....	°C
<b>Shaft power</b>	$P_a$ .....	kW
<b>Efficiency</b>	$(\eta_a)$ .....	
<b>Speed</b>	$N$ .....	1/min
<b>Sound power level (A weighted)</b>	$L_{WA}$ .....	dB
<b>Weight</b>	$m$ .....	kg

## Fittings / Accessories

- Drain plug R1/2" (B. S. P. 1/2")
- Access door
- Special coating Class K90 or P100
- Impeller blades continuously welded
- Casing continuously welded inside
- Casing continuously welded inside and outside
- Casing in 2 horizontal sections (Size 0560 upwards)
- Shaft made of stainless steel (1.4305)
- Nuts and bolts of stainless steel (1.4305)
- Tapped hole for measurement of shock impulse
- Inlet vane controller IVC
- Manual IVC- operating lever
- Volumeter IMV13
- Copper inlet cone
- Relubrication in operation IWN01 or IWN11
  
- Inlet Guards
- Discharge Guard
- Shaft guard
- Discharge Flange
- Discharge Flex (with flexible sleeve)
- Base frame with motor rails
- Pick-a-Back (for attaching motor fan)
- Belt drive, V-belt or flat Belt
- Belt guard
- Belt guard split horizontally
- Motor
- Anti-vibration mounts

# RZR 13-0400/-1000

## Specifications

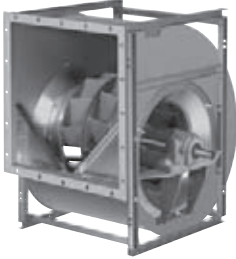

### High performance centrifugal fan *rotavent* RZR 13-0400/-1000

double inlet belt drive.  
 Scroll casing stitch welded with discharge flange and heavy duty reinforced side frames, epoxy coated.  
 High performance impeller with 12 hollow section true airfoil blades inclined obliquely to the shaft axis, welded in position and epoxy coated.  
 Throat plate inclined obliquely in opposition to blade inclination.  
 Inlet cones matched to the impeller reduce entry losses to a minimum.  
 Impeller and shaft balanced as an assembly in according to DIN ISO 1940.  
 Self aligning double row ball bearings within standard plummer blocks, mounted on robust pedestal, packed with long life, high performance grease. Can be relubricated when not in service.  
 Performance data to DIN 24166 Class 1 / BS 848 Class "A".

## Fan data

<b>Fan type</b>	.....	
<b>Volume flow</b>	$Q_V$ .....	m <sup>3</sup> /h
<b>Total pressure increase</b>	$p_F$ .....	Pa
<b>Static pressure</b>	$p_{SF}$ .....	Pa
<b>Air density at fan inlet</b>	$\rho_1$ .....	kg/m <sup>3</sup>
<b>Air medium temperature</b>	$t$ .....	°C
<b>Shaft power</b>	$P_a$ .....	kW
<b>Efficiency</b>	$(\eta_a)$ .....	
<b>Speed</b>	$N$ .....	1/min
<b>Sound power level (A weighted)</b>	$L_{WA}$ .....	dB
<b>Weight</b>	$m$ .....	kg

## Fittings / Accessories

- Drain plug R1/2" (B.S.P. 1/2")
- Access door
- Special coating Class K90 or P100
- Centrifugal fan in Ex-Execution in Acc. to ATEX
- Impeller blades continuously welded
- Casing continuously welded inside
- Casing continuously welded inside and outside
- Casing in 2 horizontal sections (Size 0500 upwards)
- Shaft made of stainless steel (1.4305)
- Nuts and bolts of stainless steel (1.4305)
- Tapped hole for measurement of shock impulse
- Inlet vane controller IVC
- Manual IVC-operating lever
- Volumeter IMV13
- Copper inlet cone
- Relubrication in Operation IWN01 or IWN11
  
- Inlet Guards
- Discharge Guard
- Shaft guard
- Discharge Flange
- Discharge Flex (with flexible sleeve)
- Base frame with motor rails
- Pick-a-Back (for attaching motor fan)
- Belt drive, V-belt or flat Belt
- Belt guard
- Belt guard split horizontally
- Motor
- Anti-vibration mounts

# RZR 13-1120/-1600

## Specifications



### High performance centrifugal fan *rotavent* RZR 1120/-1600

double inlet belt drive.

Heavy duty casing of sheet steel with stiffening members, step welded and painted, with discharge flange.

Casing is split on one axis (Size 1120), split on two axis (Sizes 1250, 1400, 1600).

High performance impeller with 12 hollow section true airfoil blades inclined obliquely to the shaft axis, welded in position and epoxy coated.

Inlet cones matched to the impeller reduce entry losses to a minimum.

Impeller and shaft balanced as an assembly in accordance to DIN ISO 1940.

Self aligning double row roller bearings within standard plummer blocks, mounted on robust pedestal, packed with long life, high performance grease. Can be relubricated when not in service.

Inlet guard fitted as a standard in accordance with DIN EN 294.

Performance data to DIN 24166 Class 1 / BS 848 Class "A".

## Fan data

Fan type	.....	
Volume flow	$Q_v$ .....	m <sup>3</sup> /h
Total pressure increase	$p_F$ .....	Pa
Static pressure	$p_{sF}$ .....	Pa
Air density at fan inlet	$\rho_1$ .....	kg/m <sup>3</sup>
Air medium temperature	$t$ .....	°C
Shaft power	$P_a$ .....	kW
Efficiency	$(\eta_a)$ .....	
Speed	$N$ .....	1/min
Sound power level (A weighted)	$L_{WA}$ .....	dB
Weight	$m$ .....	kg

## Fittings / Accessories

- Drain plug R1"
- Access door
- Special coating Class K90 or P100
- Centrifugal fan in Ex-Execution in Acc. to ATEX
- Impeller blades continuously welded
- Casing continuously welded inside
- Casing continuously welded inside and outside
- Shaft made of stainless steel (1.4305)
- Nuts and bolts of stainless steel (1.4305)
- Tapped hole for measurement of shock impulse
- Volumeter IMV13
- Copper inlet cone
- Relubrication in operation IWN01 or IWN11
  
- Discharge Guard
- Shaft guard
- Discharge Flange
- Discharge Flex (with flexible sleeve)
- Base frame with motor rails
- Belt drive, V-belt or flat Belt
- Belt guard
- Belt guard split horizontally
- Motor
- Anti-vibration mounts



**The fan sets**

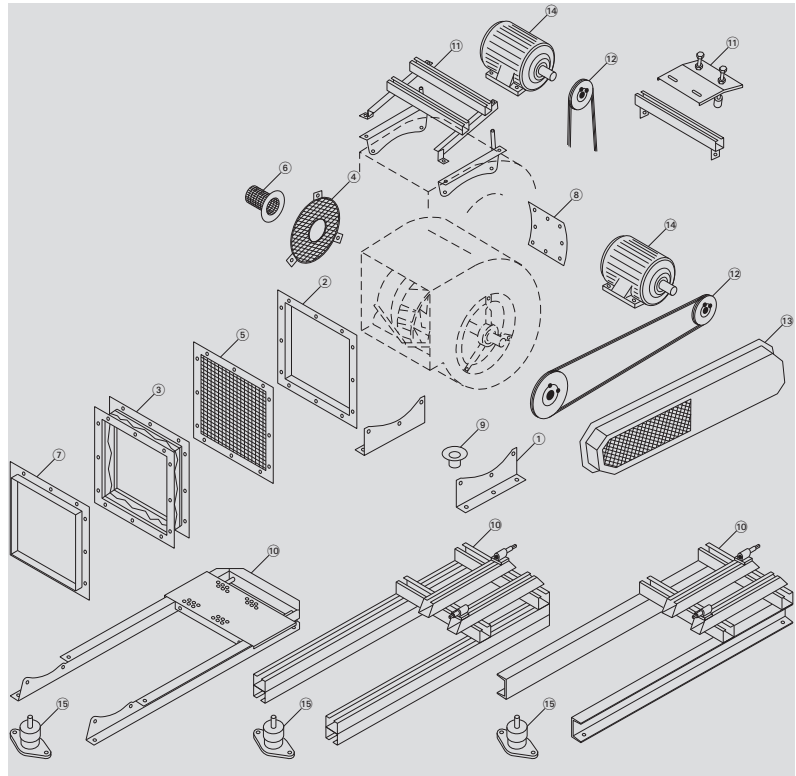
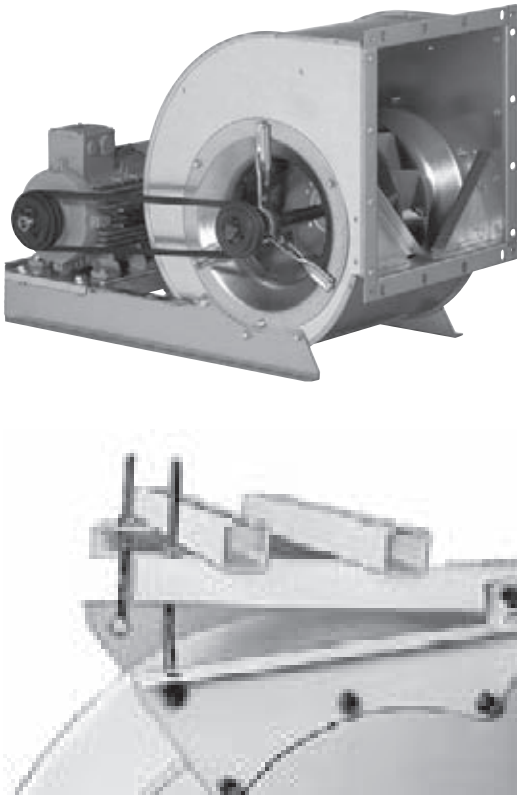

- [1] Mounting feet
- [2] Discharge flange
- [3] Discharge flex
- [4] Inlet guard
- [5] Discharge guard
- [6] Shaft guard
- [7] Mounting flange
- [8] Inspection door
- [9] Drain plug
  - extended corrosion protection
  - ATEX-Execution (RZR)
  - Impellerblades continuously welded (RZR)
  - Casing continuously welden-inside (RZR)
  - Casing continuously welden- inside/outside (RZR)
  - Split casing (RZR 13/19)
  - Shaft from stainless steel
  - Nuts and bolts from stainless steel
  - Thread for impuls sensor fitting (GSM)
  - Inlet vane controller (RZR)
  - Hand-operated-control for inlet vane controller (RZR)
  - Volumeter (RZR)
  - Copper inlet cone
  - Aluminium inlet cone
  - hot dip galvanised side frame (ADH/RDH)
  - relubricatable bearings
  -
- Fan set** (ADH/RDH on request)
- [10] Base frame
- [11] Pick-a-Back
- [12] Belt drive
- [13] Drive guard
  - Belt guard split horizontally
  - Access door on belt guard
  - Opening on belt guard for speed measuring device
- [14] Drive motor
- [15] Anti-vibration mounts



**Gebhardt fan systems – the "completely carefree" package for installation fans with belt drive**

Fan systems with components tailored for each other, precisely assembled and adjusted, individually tested, delivered quickly and on time, allow for problem-free processing and ensure long and reliable operation.

Size has its price so we build as small as possible





- Optimised base frame lengths, tailored to the casing position and motor size and small system construction heights save valuable space in the air conditioning unit
- Various casing and drive positions allow for individual adjustment to the most diverse applications
- Optimised flat belt drives allow for efficient operation with a high level of convenience

Where required, we deliver our fan systems with safety equipment complying with DIN EN 294 for safe operation!

**e.g. Belt guard**

- also as segmented design
- also with inspection hole
- also with rotation speed measurement opening.

**Fan set diversity**

Version	Description	Figure
Pick-A-Back	for sizes 0200/-0355	
Pick-A-Back	for sizes 0400/-1000	
Compact base frame	Integrated compact base frame for sizes up to 0500.	
Base Frame, CC-profile	Base frames made from CC-profiles with length optimisation.	
Base Frame, U-profile	Heavy duty base frame made from U-profiles, welded and painted, from size 0800 upward.	

# Fittings / Accessories

## Drain Plug



If the fan is installed outside, or if conveying a medium containing humidity, condensation of water may accumulate inside the fan scroll.  
 For extraction of this water a condense water drain has to be installed at the lowest point of the scroll.

The drain will be provided with a thread for connecting it to a piping.  
 At order please indicate the required casing position.

### Connecting thread / hole

ADH / RDH = female thread R 1/8"

AT = drain hole

RZR 0200 /-1000 = male thread R1/2"

RZR 1120 /-1600 = male thread R 1"

## Dimensions

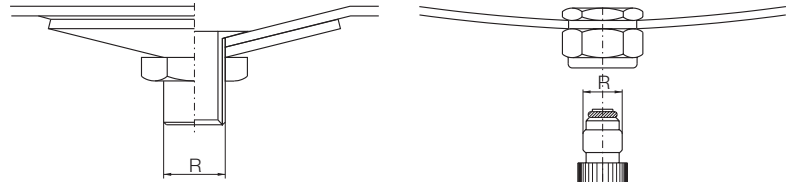

## Inspection Door



For the purposes of maintenance and cleaning there is an opening, which can be securely closed by means of an access door, in the fan casing.

As it can only be opened with a tool, the access door complies with safety and accident prevention regulations. Additional securing with locking bars can be supplied on request.

The site and orientation of the inspection opening depends on the casing position.

The position should be specified when ordering according to the following diagram: e.g. Access door, Pos. 2.

## Inspection Door Positions

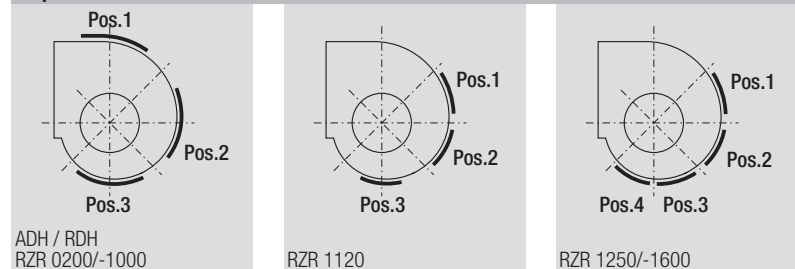

ADH / RDH  
RZR 0200/-1000

RZR 1120

RZR 1250/-1600

## Dimensions in mm, subject to change.

ADH ..-		RDH ..-		RZR ..-	
0160/-0180	100 × 230	0180	100 × 230	-	
0200/-0280	240 × 240	0200/-0280	240 × 240	0200	160 × 160
0315/-0560	360 × 360	0315/-0560	360 × 360	0225/-0315	210 × 210
0630/-1000	500 × 500	0630/-1000	500 × 500	0355/-1000	310 × 310
-	500 × 500	1120/-1400	500 × 500	1120/-1600	500 × 500

# Fittings / Accessories

## Corrosion Protection Systems



Nicotra-Gebhardt fans are treated with high quality corrosion protection as standard. Under extreme operating conditions, however, additional corrosion protection is advisable.

Depending on the use to which the fan is to be put and the degree of exposure to corrosion, we offer various anti-corrosion protection measures.

### Corrosion protection - Class S40

Degreasing, ironphosphating

- **Powder coating** - Layer thickness  $\geq 40\mu\text{m}$ , Colour RAL 7039
- **Wet lacquering** - Layer thickness  $\geq 40\mu\text{m}$  (primer + lacquer finish), Colour RAL 7039

### Corrosion protection - Class K90

Degreasing, ironphosphating

- **Powder coating** Layer thickness  $\geq 90\mu\text{m}$ , Colour RAL 7039
- **Wet lacquering** Layer thickness  $\geq 90\mu\text{m}$  (primer + lacquer finish), Colour RAL 7039

### Corrosion protection - Class P100

Degreasing, ironphosphating

- **Thermoplastic powder coating** - Layer thickness  $\geq 100\mu\text{m}$ , Colour RAL 7001

### ADH / RDH

Extended corrosion protection for series ADH, AT and RDH only available on request.

## Continuously welded blades



Impeller blades can be continuously welded in order to increase the corrosion resistance when conveying a humid or slightly aggressive medium. The continuous welding has no influence on the material resistance or on the max. tip speed.

## Continuously welded scroll



The casing can be continuously welded in order to increase the corrosion resistance when conveying a humid or slightly aggressive medium. By continuous welding the casing is provided with additional impermeability.

- **GEH 01** - Casing inside continuously welded
- **GEH 02** - Casing inside and outside continuously welded

# Fittings / Accessories

## Split Casing



There may be a lot of reasons to choose a split casing, the advantages of split casings are:

- smaller openings for fan chambers
- easier refitting of fan
- easier transport to site
- easier access to impeller for cleaning and maintenance

The joint face on the casing position runs horizontally above or under the fan axis (see drawing).

The reinforced side frames are not divisible.

The fan is supplied fully assembled.

**Dimensions** in mm, subject to change.

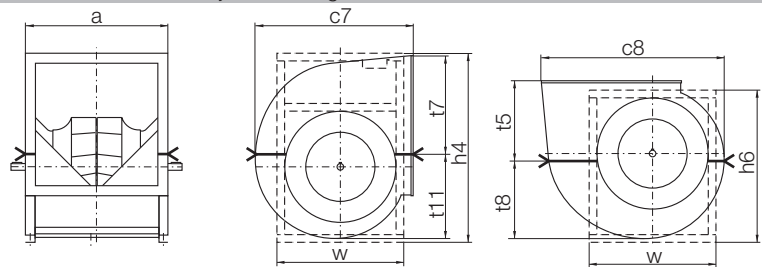

RZR	RZR		a	c7	c8	h4	h6	t5	t7	t8	t11	w
13-	19-	0500	709	822	950	957	783	410	473	409	477	652
13-	19-	0560	785	914	1061	1083	884	458	531	456	530	743
13-	19-	0630	872	1021	1188	1204	984	511	594	510	594	820
13-	19-	0710	967	1143	1331	1350	1100	572	666	571	665	905
13-	19-	0800	1086	1280	1498	1520	1245	640	749	640	749	1035
13-	19-	0900	1219	1439	1686	1707	1386	719	843	720	843	1140
13-	19-	1000	1356	1568	1847	1869	1509	784	923	784	924	1230

## Stainless Steel Shaft



For applications where there is an increased risk of corrosion, an optional shaft made of stainless steel can be supplied.

**ADH / AT / RDH**

Stainless steel 1.4301 / AISI 304 / XCrNi18-10

**RZR**

Stainless steel 1.4305

## Stainless Steel Nuts and Bolts



For applications where there is an increased risk of corrosion, the connecting elements of the fan can be ordered made of stainless steel.

## Impuls Sensor Thread



A tapped hole M6 or M8 can be provided in the pedestal bearing cast housing for admission of sensors to measure the shock impulses.

(The measuring connecting piece is not included in the scope of delivery).

# Fittings / Accessories

## Volumeter

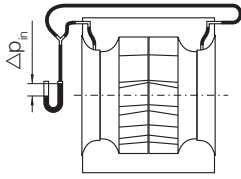

$$q_v = K \times \sqrt{\frac{2}{\rho} \times \Delta p_{Dü}}$$

With the flow measuring device it is possible to easily measure/monitor the flow rate after the fan is installed. A pressure tapping at a predetermined position on the inlet cone is provided whereby the differential pressure in relation to the static pressure is measured in front of the inlet cone in a static atmosphere.

- **volume flow  $q_v$  [m<sup>3</sup>/h]**
- **calibration factor  $K$  [m<sup>2</sup>s/h]**
- **density of media  $\rho$  [kg/m<sup>3</sup>]**
- **pressure difference at cone  $\Delta p_{Dü}$  [Pa]**

In order to calculate the flow rate, a calibrating factor "K" is required. This factor is determined by comparative measurement on a standard test rig.

- Measuring connector in inlet cone
- Hose pipe to connecting piece in the side wall
- Connecting piece (external diameter of 6mm) for the pressure measurement

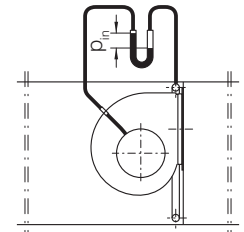

### Standard-calibration faktor K10 <10%

Where fans are built into a plenum, the pressure difference between the static pressure in the inlet side plenum and the pressure on the inlet cone is to be measured. It must be ensured that the static pressure to be measured in front of the inlet cone is not tampered by dynamic pressure fractions. It is often recommended to arrange a ring of points on the wall facing the outlet side as illustrated in the sketch. When using the K-factors specified below, a minimum clearance of 0.5×D between the inlet cone of the fan and the side wall of the plenum must be maintained. Indentations that obstruct the flow to the cone can lead to faults when measuring the flow rate. In the event that the differential pressure is fed via a pressure sensor, the signal can also be used for regulating purposes.

### Calibration factors

Type	Standard calibration factor K10 m <sup>2</sup> s/h
IMV 13-0200	100
IMV 13-0225	115
IMV 13-0250	140
IMV 13-0280	165
IMV 13-0315	190
IMV 13-0355	235
IMV 13-0400	290
IMV 13-0450	360
IMV 13-0500	460
IMV 13-0560	560
IMV 13-0630	730
IMV 13-0710	960
IMV 13-0800	1180
IMV 13-0900	1450
IMV 13-1000	1850
IMV 13-1120	2400
IMV 13-1250	3000
IMV 13-1400	3800
IMV 13-1600	4700

## Inlet Cones



Inlet cone of copper or aluminium prevent the production of sparks during operation. These can be employed when spark protection is required, but ATEX is not mandatory.

## Hot Dip Galvanised Side Frame

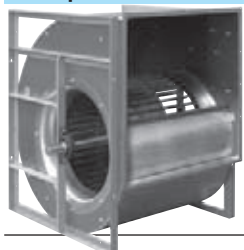

### Fan Ranges ADH/RDH E4, E6, E7 or K, K1, K2

For applications where an increased corrosion protection is required the reinforcing side frames of the casing can be executed in hot dip galvanisation as an option.

# Fittings / Accessories

## Relubrications



ADH / RDH

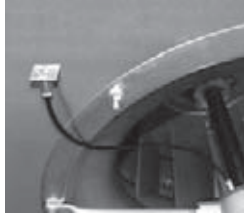

RZR rotavent

### Series RZR

The lubrication unit IWN allows the fan bearings to be greased even when in operation.

The lubrication tubes screwed into the bearing housing are lead out and fastened at the side wall of the fan. If desired, the lubrication tubes can be lead to the drive side of the fan.

- **IWN 01** - uses standard grease
- **IWN 11** - uses moisture resistant grease
- 

For more details see "Technical Description" - "Bearings"!

### Series ADH, RDH

The bearing housings of the fan ranges ADH/RDH E4, E6, E7 or K, K1, K2 and AT-AR, -TIC are equipped with directly fitted grease nipples.

## Mounting feet



Feet made from galvanized steel, either mounted or loose, enable the fan to be installed with a 0, 90 and 270 orientation.

## Protection guards



The fans are designed for installation in equipment and as standard are not equipped with protective guards.

**They should not be put into operation before all protective devices are fitted and connected!**

Protective measures must be carried out as set out in DIN EN ISO 12100 "Safety of machinery - Basic concepts, general principles for design".

If the application of the fan allows free access to the inlet and discharge apertures, safety devices must be put in place on the fan in accordance with DIN EN ISO 13857! Suitable safety guards are available as an optional extra.

## Shaft Guards

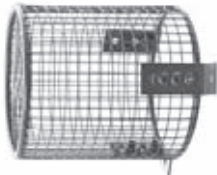

Contact guard for the free end of the shaft for double inlet centrifugal fans. Models in accordance with DIN EN ISO 13857, made of painted steel mesh.

## Flanges



Made from galvanized or painted steel, to connect ducts and system components to the fan outlet side.

## Flexible Connections



Connecting piece with elastic intermediate section for the vibration or impact-noise decoupled connection of the fan to the system or unit. Made out of two connecting flanges with elastic intermediate section.

### Temperature range / Application

- Standard up to +80C
- ATEX max. +60C

# Fittings / Accessories

## Anti Vibration Mounts

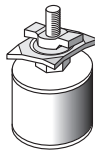
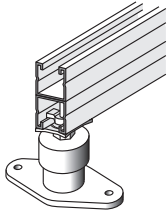

Fastening for CC-profile



Fastening for U-profile

AV mounts are designed to prevent noise and vibrations being transmitted through the base of the fan.

AV mounts should be mounted beneath the fan base frame so the weight and spring deflections are evenly distributed. They should not be mounted symmetrically because a counter force is induced into the system by the pressure created by the working fan.

It is difficult for the manufacturer to establish the position of the AV mounts to suit all types of application.

Vibration and noise insulation can also be improved by ensuring that the fan is connected to its external environment by a flexible coupling.

**Rubber pads** and **buffers**, for both vibration and noise insulation at fan speeds above 1400 rpm or 850 rpm.

**Rubber buffers**, for noise insulation only at fan speeds under 800 rpm or 1700 rpm.

**Spring diffusers** with noise insulation layer and height adjustment, for both vibration and noise insulation at fan speeds above 400 rpm.

**Available AV mounts for different fans, see proSELECTA II.**

**The AVM-mounts are supplied with the suitable mounting material for the base frame.**

## Anti Vibration Rubber Pads

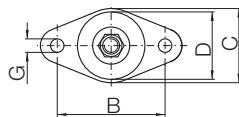
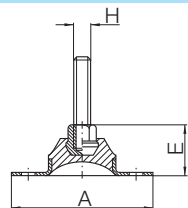

ZBD	ZBD	A	B	C	D	E	G	H
21-6035A*	21-6035C*	60	45	35	30	20	5	M6
21-6065A*	21-6065C*	60	45	35	30	20	6	M6
21-5935A*	21-5935C*	90	70	50	45	32	9	M10
21-5950A*	21-5950C*	90	70	50	45	32	9	M10

\* A = for U-profile, C = for CC-profile

## Anti Vibration Rubber Buffers

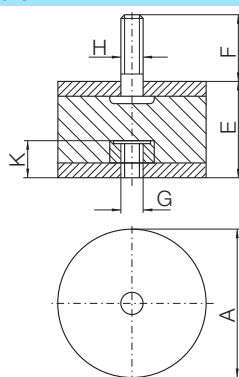

ZBD	ZBD	A	E	F	G	H	K
01-0405A*	01-0405C*	20	25	16	M 6	M 6	6.5
03-0503A*	03-0503C*	25	15	11	M 6	M 6	6.5
01-0504A*	01-0504C*	25	20	11	M 6	M 6	6.5
03-0806A*	03-0806C*	40	30	21	M 8	M 8	9.5
03-1007A*	03-1007C*	50	34	26.5	M 10	M 10	10.5
03-1510A*	03-1510C*	75	50	39	M 12	M 12	12.5
02-2008A*	02-2008C*	100	40	44	M 16	M 16	16.5

\* A = for U-profile, C = for CC-profile

# Fittings / Accessories

## Anti Vibration Spring Diffusers

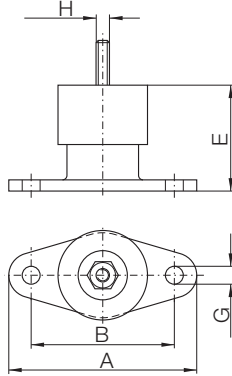

ZBD	ZBD	A	B	C	D	~ E	~ F	G	H
60-0101A*	60-0101C*	130	100	70	72	70-50	35	13	M10
60-0103A*	60-0103C*	130	100	70	72	70-50	35	13	M10
60-0105A*	60-0105C*	130	100	70	72	70-50	35	13	M10
60-0108A*	60-0108C*	130	100	70	72	70-50	35	13	M10
60-0112A*	60-0112C*	150	120	82	92	90-75	35	13	M12
60-0120A*	60-0120C*	150	120	82	92	90-75	35	13	M12
60-0130A*	60-0130C*	150	120	82	92	90-75	35	13	M12
60-0150A*	60-0150C*	150	120	82	92	110-85	35	13	M12

\* A = for U-profile, C = for CC-profile

## Anti Vibration Spring Diffusers

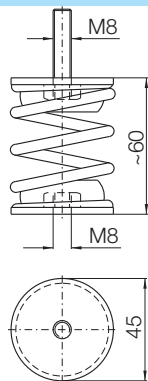

ZBD	ZBD
SP-7701A*	SP-7701C*
SP-7702A*	SP-7702C*
SP-7703A*	SP-7703C*
SP-7704A*	SP-7704C*
SP-7705A*	SP-7705C*
SP-7706A*	SP-7706C*
SP-7707A*	SP-7707C*

\* A = for U-profile, C = for CC-profile

## Anti Vibration Spring Diffusers

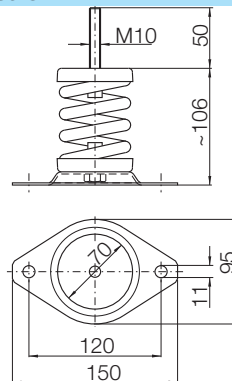

ZBD	ZBD
SP-7501A*	SP-7501C*
SP-7502A*	SP-7502C*
SP-7503A*	SP-7503C*
SP-7504A*	SP-7504C*
SP-7505A*	SP-7505C*
SP-7506A*	SP-7506C*
SP-7507A*	SP-7507C*
SP-7508A*	SP-7508C*

\* A = for U-profile, C = for CC-profile

## Anti Vibration Spring Diffusers

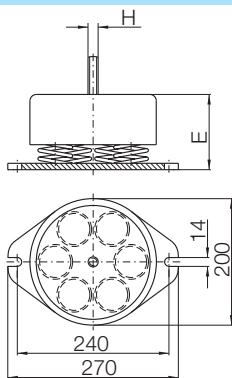

ZBD	ZBD	E	H	kg
80-W603A*	80-W603C*	68-101	M 16	8.3
80-W605A*	80-W605C*	76-101	M 16	8.6
80-W608A*	80-W608C*	86-105	M 16	9.0
80-W612A*	80-W612C*	84-104	M 16	9.3
80-W616A*	80-W616C*	92-105	M 24	9.7

\* A = for U-profile, C = for CC-profile



# Fan Sets

## Base Frame with Belt Tensioning Device

G2Z-component size 0200/-0500 (only RZR 11/19)

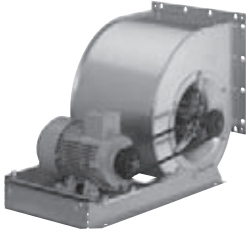

This compact base frame with integrated motor tensioning slider provides optimum compactness and easiest handling.

- The base frame made of galvanized sheet steel is screwed directly onto the fan (without any casing feet) – the result being the low overall height of the system.
- The overall length depending on the casing position and size of the motor is a further factor influencing the optimum compactness.
- The integrated tensioning slider considerably simplifies re-adjustment of the belt drive during maintenance and service work.

G1Z-component size 0400/-0710



The base frames up to motor size 180 are manufactured from galvanized CC-profiles. The anti-vibration mounts in the CC-profile provide infinitely variable adjustment. From motor size 200 the base frames are of U-profile, welded and painted. Fitted motor tensioning tracks that allow the motor to be shifted longitudinally, allow for the simple adjustment of the belt tension.

G1Z-component size 0800/-1600



Base frame of stable U-profiles, welded and painted, with holes for attaching the anti-vibration mounts. Fitted motor tensioning tracks that allow the motor to be shifted longitudinally, allow for the simple adjustment of the belt tension.

### Equipment

- FKS hot-dip galvanized for U-profile base frame

## Pick-A-Back



This allows the motor to be fixed directly onto the fan casing, where space around the fan is limited. One side of the pick-a-back is fixed to the casing so that it swivels, while the other is supported on a spindle. Thus the pick-a-back becomes adjustable to leave room for tensioning the drive belt. The various motor arrangements and casing positions are shown in the drawings.

The accompanying tables also show the maximum permissible motor sizes. When using a pick-a-back arrangement and fitting anti vibration mounts (AVM) an additional base frame for fitting the AVM may be required depending on the position of the centre of gravity of the whole fan set.

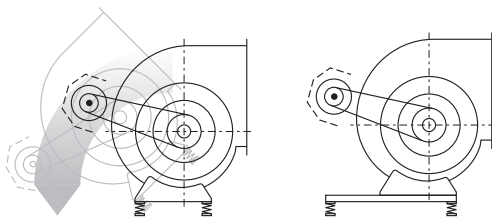

# Fan Sets

## Belt Drive

### Wedge Belts

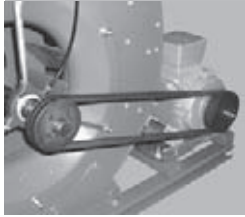

High performance narrow V-belts in accordance with DIN 7753 are temperature stable up to +80 C, resistant to mineral oils and electrostatically conductive. The belt pulleys are made of high quality cast iron and, depending on the peripheral velocity and number of grooves, are statically (G 16) or dynamically (G 6.3) balanced. They are fastened to the shaft of the motor or fan by means of a clamping bush.

### Flat Belts



The flat belt drives employed are made using the most modern technology and materials. They are the centrepiece of highly developed, powerful belt drives. This modern flat belt drive has distinct advantages over traditionally employed V-belt drives and exceeds it in efficiency, quiet running and economy.

#### Overview of the advantages:

- higher efficiency
- longer service life
- quieter running
- easy to install
- low maintenance
- no wear on the belt - so it is possible to dispense with the 2nd filter stage in the air conditioning unit (in accordance with VDI 6022)

## Belt Guard



Totally enclosed belt guards are made from galvanised sheet steel in accordance with DIN EN 294-1.

The front section can be removed for maintenance. If there is no standard belt guard available for the selected belt drive (see table), a suitable belt guard will be made as a welded construction and then coated.

#### Features

- belt guard split horizontally
- access door on belt guard
- opening on belt guard for speed measuring device

Dimensions in mm, subject to change.

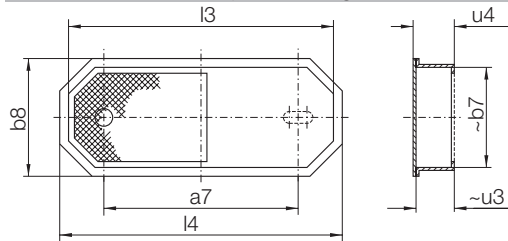

RBS	a7 <sub>max</sub>	DW <sub>max</sub>	b8	b7	s5	u4	u3	l4	l3
01-....-01	250	90	194	159	97	72	69	444	404
01-....-02	300	90	194	159	97	72	69	494	454
01-....-03	350	160	264	229	132	72	69	614	574
01-....-04	400	160	264	229	132	72	69	664	624
01-....-05	450	160	264	229	132	72	69	714	674
01-....-06	500	160	264	229	132	72	69	764	724
01-....-07	600	160	264	229	132	72	69	864	824
01-....-08	700	125	264	229	132	72	69	964	924
01-....-09	800	125	264	229	132	72	69	1064	1024
01-....-10	900	125	264	229	132	72	69	1164	1124
01-....-11	450	250	344	304	172	122	119	794	754
01-....-12	500	250	344	304	172	122	119	844	804
01-....-13	600	250	344	304	172	122	119	944	904
01-....-14	700	315	484	444	242	122	119	1184	1144
01-....-15	800	315	484	444	242	122	119	1284	1244
01-....-16	900	315	484	444	242	122	119	1384	1344
01-....-17	1000	315	484	444	242	122	119	1484	1444
01-....-18	1100	315	484	444	242	122	119	1584	1544
01-....-19	1200	315	484	444	242	122	119	1684	1644

.... Placeholder for fan-size

DW<sub>max</sub> Diameter of the biggest pulley

a7<sub>max</sub> Maximum axle centre distance

# RZR 11-0200/-0500

## Fan set arrangement with base frame

Dimensions in mm, subject to change.

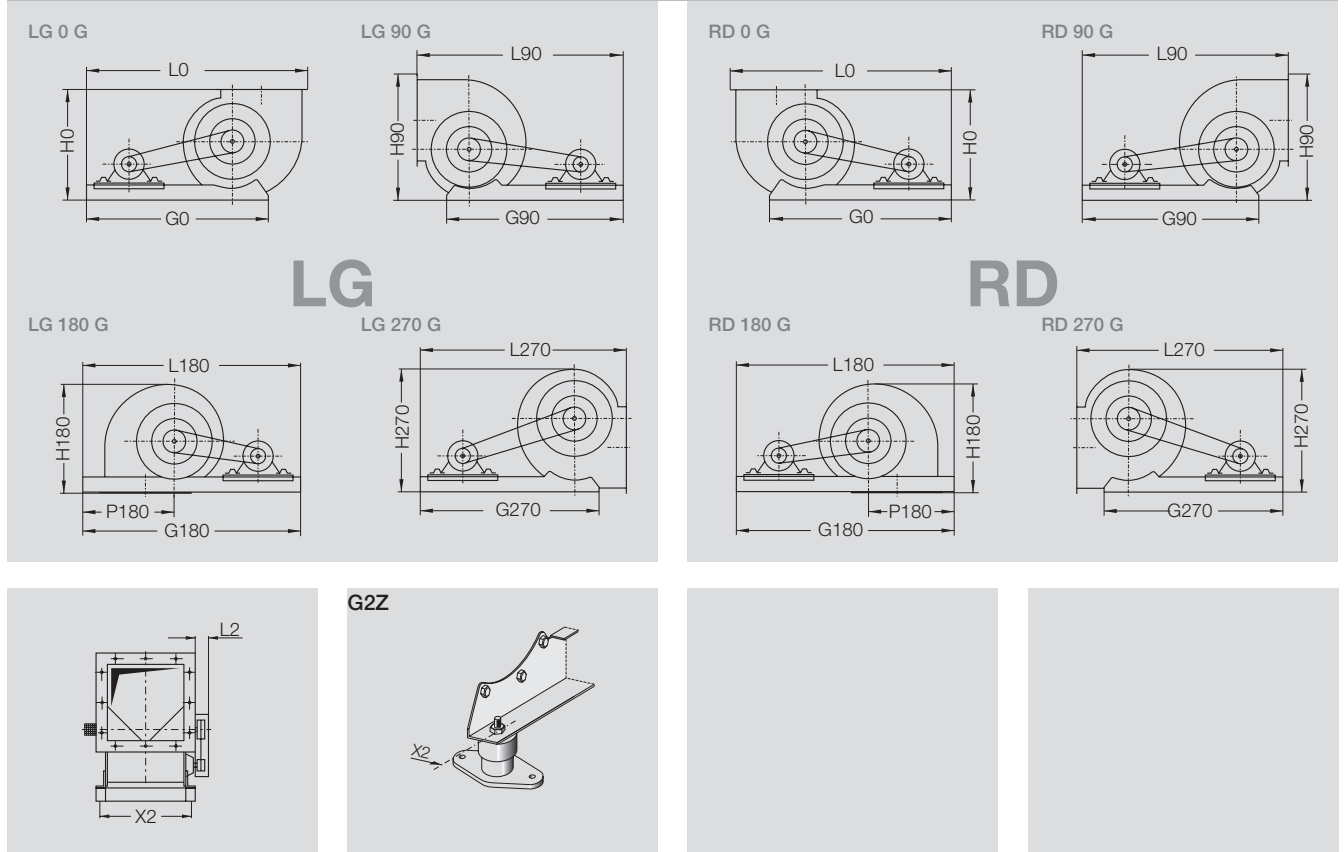

RZR	RZR		② G0	② G90	② G180	② G270	H0	H90	H180	H270
11-	19-	0200	625	650	880	650	358	408	356	386
11-	19-	0225	680	710	925	710	404	467	401	431
11-	19-	0250	705	730	974	730	440	510	438	477
11-	19-	0280	725	755	1031	755	489	569	485	531
11-	19-	0315	750	785	1094	785	542	623	537	597
11-	19-	0355	845	885	1207	885	603	689	601	670
11-		0400	990	970	1350	970	671	773	667	749
11-		0450	1030	1010	1440	910	755	868	750	840
11-		0500	1070	1050	1530	1050	827	956	821	929

RZR	RZR		② L0	② L90	② L180	② L270	L2	P180	X2	Motor max.	Base frame ~ kg
11-	19-	0200	745	740	880	740	100	396	286	132	6
11-	19-	0225	793	792	925	792	100	423	322	132	7
11-	19-	0250	843	829	974	829	100	450	356	132	7.5
11-	19-	0280	893	876	1031	876	100	482	395	132	8
11-	19-	0315	952	931	1094	931	100	520	438	132	9
11-	19-	0355	1087	1090	1207	1060	100	552	487	160	10
11-		0400	1219	1120	1350	1120	120	587	546	180	11
11-		0450	1315	1203	1440	1203	120	646	612	180	12
11-		0500	1400	1279	1530	1279	120	700	680	180	14

② The base frame length has been determined with the always largest admitted motor size. With smaller motors the frame length will be reduced.

For accurate dimensions use pro SELECTA II or on request.

# RZR 11-0400/-0710

## Fan set arrangement with base frame

Dimensions in mm, subject to change.

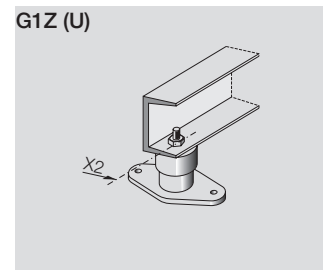
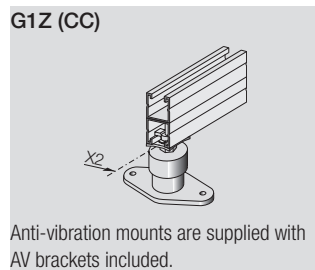
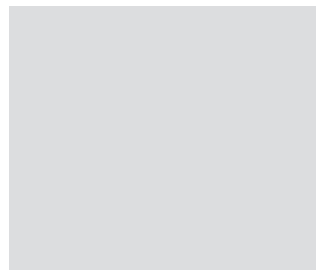
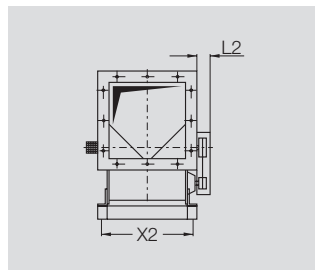
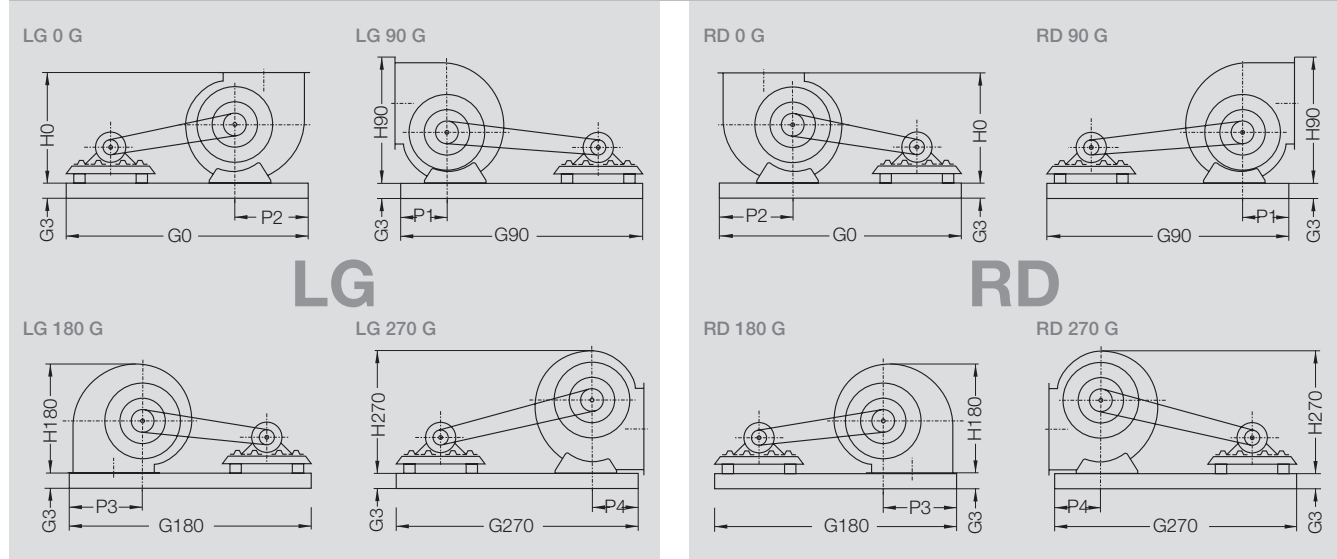

RZR		② G0	② G90	② G180	② G270	63-71	80-90	100-132	160-180	200-225	250-280
11-	0400	1240	1300	1650	1240	82-CC	82-CC	82-CC	82-CC	80-U ③	-
11-	0450	1300	1350	1740	1298	82-CC	82-CC	82-CC	82-CC	80-U ③	-
11-	0500	1434	1405	1772	1405	82-CC	82-CC	82-CC	82-CC	80-U ③	-
11-	0560	1558	1508	1908	1508	82-CC	82-CC	82-CC	82-CC	80-U ③	-
11-	0630	1600	1574	2006	1574	-	82-CC	82-CC	82-CC	80-U ③	-
11-	0710	1708	1680	2145	1680	-	82-CC	82-CC	82-CC	-	-
11-	0710-U	1700	1700	2115	1700	-	-	-	-	100-U	120-U ③

RZR		H0	H90	H180	H270	L2	P1	P2	P3	P4	X2	Motor Base frame ~ kg			
												max.	CC	80-U	100-U
11-	0400	671	773	667	749	120	275	355	669	275	550	225	31	③	③
11-	0450	755	868	750	840	120	320	408	718	320	614	225	32	③	③
11-	0500	827	956	821	929	120	348	452	766	348	682	225	33	60	-
11-	0560	921	1071	914	1041	150	384	502	851	384	759	225	34	63	-
11-	0630	1028	1195	1021	1168	150	432	566	915	432	846	225	35	68	-
11-	0710	1152	1341	1143	1316	180	479	625	1014	479	943	180	37	-	-
11-	0710-U	1152	1341	1143	1316	180	-	-	-	-	943	250	-	94	145

② The base frame length has been determined with the always largest admitted motor size. With smaller motors the frame length will be reduced.  
For accurate dimensions use pro SELECTA II or on request.

③ Dimensions on request

# RZR 12-0200/-0710

## Fan set arrangement with base frame

Dimensions in mm, subject to change.

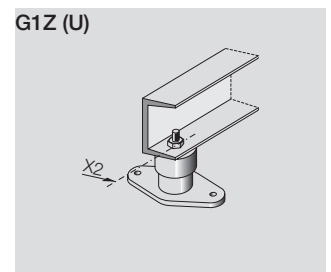
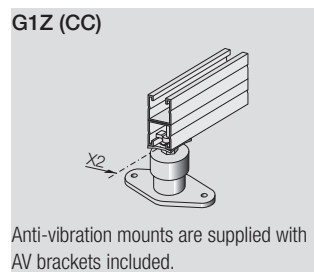
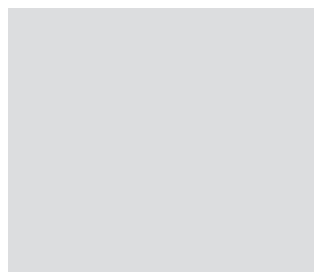
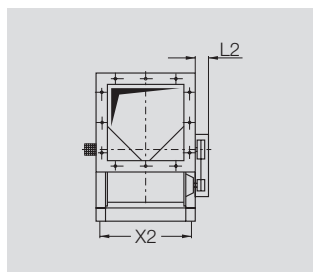
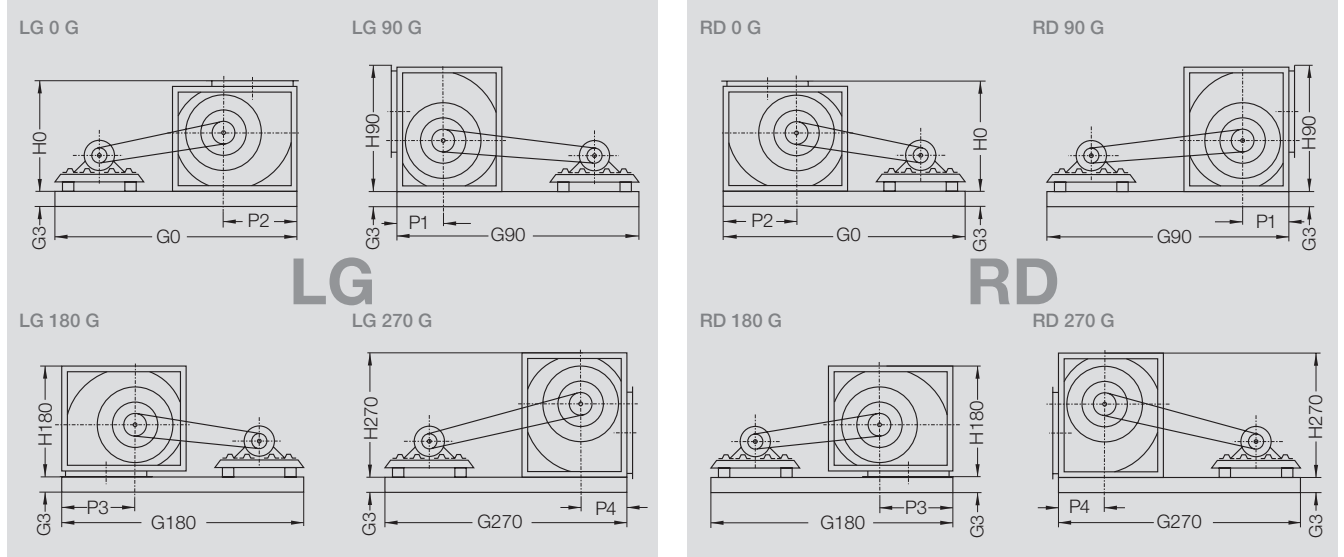

Anti-vibration mounts are supplied with AV brackets included.

RZR		② G0	② G90	② G180	② G270	63-71	80-90	100-132	160-180	200-225	250-280
12-	0200	④	④	④	④	-	-	-	-	-	-
12-	0225	④	④	④	④	-	-	-	-	-	-
12-	0250	④	④	④	④	-	-	-	-	-	-
12-	0280	④	④	④	④	-	-	-	-	-	-
12-	0315	④	④	④	④	-	-	-	-	-	-
12-	0355	④	④	④	④	-	-	-	-	-	-
12-	0400	1430	1312	1655	1312	82-CC	82-CC	82-CC	82-CC	80-U ③	-
12-	0450	1522	1388	1740	1388	82-CC	82-CC	82-CC	82-CC	80-U ③	-
12-	0500	1610	1460	1830	1460	82-CC	82-CC	82-CC	82-CC	80-U ③	-
12-	0560	1736	1561	1958	1561	82-CC	82-CC	82-CC	82-CC	80-U ③	-
12-	0630	1865	1670	2078	1670	-	82-CC	82-CC	82-CC	80-U ③	-
12-	0710	2008	1784	2235	1784	-	82-CC	82-CC	82-CC	-	-
12-	0710-U	2035	1840	2235	1840	-	-	-	-	100-U	120-U ③

RZR		H0	H90	H180	H270	L2	X2	Motor max.	Base frame ~ kg CC	80-U	100-U
12-	0200	④	④	④	④	④	④	④	④	④	④
12-	0225	④	④	④	④	④	④	④	④	④	④
12-	0250	④	④	④	④	④	④	④	④	④	④
12-	0280	④	④	④	④	④	④	④	④	④	④
12-	0315	④	④	④	④	④	④	④	④	④	④
12-	0355	④	④	④	④	④	④	④	④	④	④
12-	0400	669	769	669	750	120	550	225	31	③	③
12-	0450	753	865	753	841	120	614	225	32	③	③
12-	0500	825	955	825	931	120	682	225	33	60	-
12-	0560	920	1067	920	1046	150	759	225	34	63	-
12-	0630	1027	1195	1027	1173	150	846	225	35	68	-
12-	0710	1152	1341	1152	1324	180	943	180	37	-	-
12-	0710-U	1152	1341	1152	1324	180	-	250	-	94	155

② The base frame length has been determined with the always largest admitted motor size. With smaller motors the frame length will be reduced.  
For accurate dimensions use pro SELECTA II or on request.

③ Dimensions on request  
④ The RZR 12-0200 to -0355 can only be supplied as standard basic models.

# RZR 14-0315/-1000

## Fan set arrangement with base frame

Dimensions in mm, subject to change.

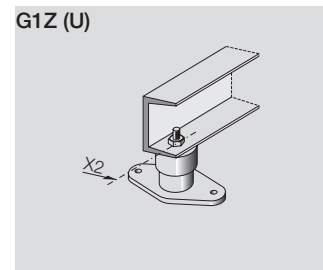
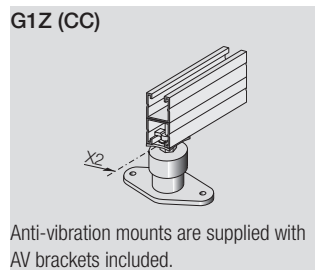
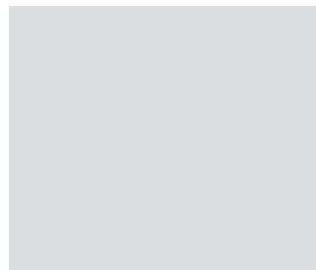
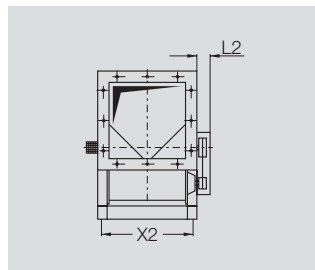
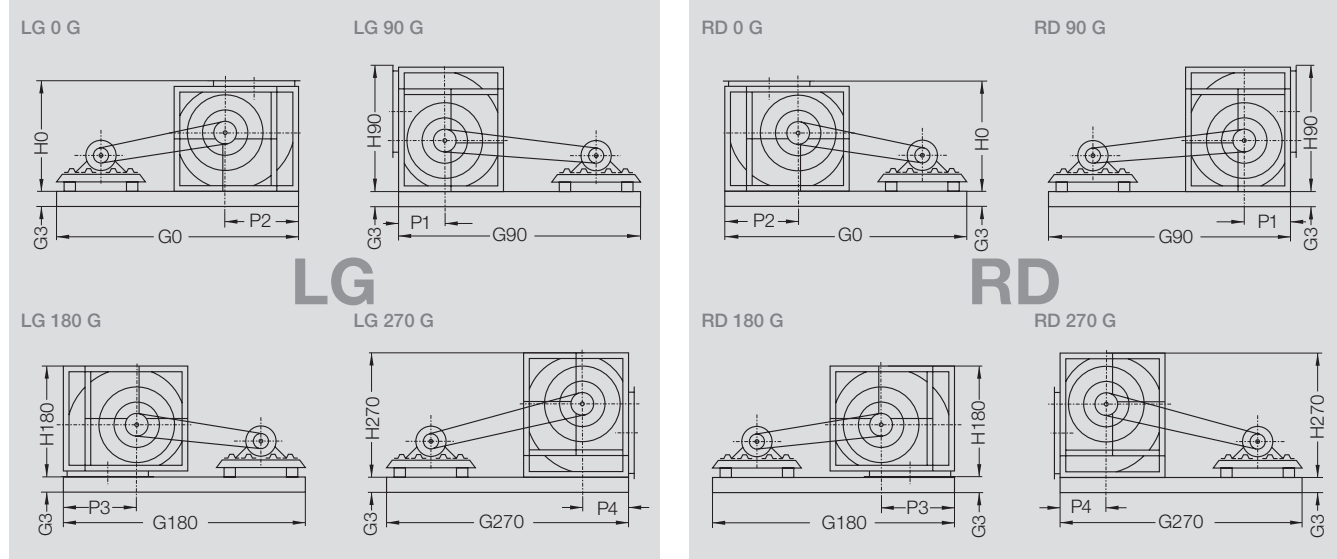

RZR		② G0	② G90	② G180	② G270	63-71	80-90	100-132	160-180	200-225	250-280
14-	0315	1276	1182	1500	1182	80-CC	80-CC	80-CC	80-CC	-	-
14-	0355	1350	1242	1569	1242	80-CC	80-CC	80-CC	80-CC	-	-
14-	0400	1430	1312	1655	1312	80-CC	80-CC	80-CC	80-CC	-	-
14-	0450	1522	1388	1740	1388	80-CC	80-CC	80-CC	80-CC	-	-
14-	0500	1610	1460	1830	1460	80-CC	80-CC	80-CC	80-CC	-	-
14-	0560	1736	1561	1958	1561	80-CC	80-CC	80-CC	80-CC	80-U ③	-
14-	0630	1865	1670	2078	1670	-	80-CC	80-CC	80-CC	80-U ③	-
14-	0710	2008	1784	2235	1784	-	80-CC	80-CC	80-CC	80-U ③	-
14-	0800	2220	2040	2220	2040	-	80-CC	80-CC	80-CC	80-U ③	-
14-	0900	2584	2264	2678	2264	-	80-CC	80-CC	80-CC	80-U ③	-
14-	1000	2744	2394	2744	2394	-	80-CC	80-CC	80-CC	100-U	-

RZR		H0	H90	H180	H270	L2	X2	Motor Base frame ~ kg max.	CC	80-U	100-U
14-	0315	535	611	535	588	~100	436	160	31 ③	③ ③	③
14-	0355	598	685	598	665	~100	495	160	32 ③	③ ③	③
14-	0400	664	769	664	750	~120	549	160	31 ③	③ ③	③
14-	0450	753	845	753	841	~120	621	160	32 ③	③ ③	③
14-	0500	825	955	825	931	~120	690	160	33	60	-
14-	0560	920	1066	920	1046	~150	767	180	34	63	-
14-	0630	1028	1194	1028	1174	~150	855	180	35	68	-
14-	0710	1152	1341	1152	1320	~180	954	180	37	94	155
14-	0800	1290	1509	1290	1482	~180	1061	180	-	67	98
14-	0900	1442	1695	1442	1667	~200	1183	225	-	72	105
14-	1000	1573	1859	1573	1829	~200	1321	225	-	77	111

② The base frame length has been determined with the always largest admitted motor size. With smaller motors the frame length will be reduced.

③ Dimensions on request

For accurate dimensions use pro SELECTA II or on request.

# RZR 13-0400/-1000

# RZR 18-0400/-1000

## Fan set arrangement with base frame

Dimensions in mm, subject to change.

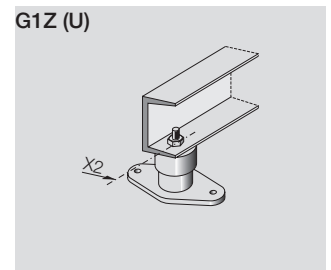
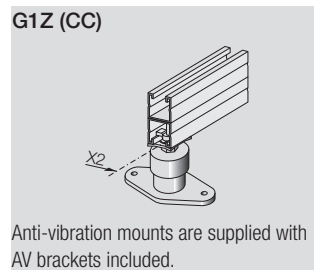
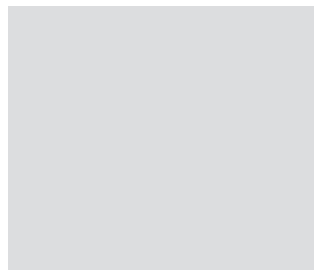
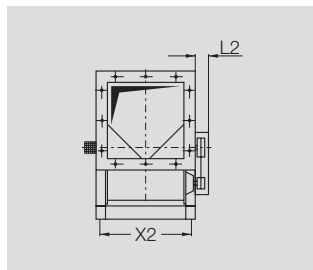
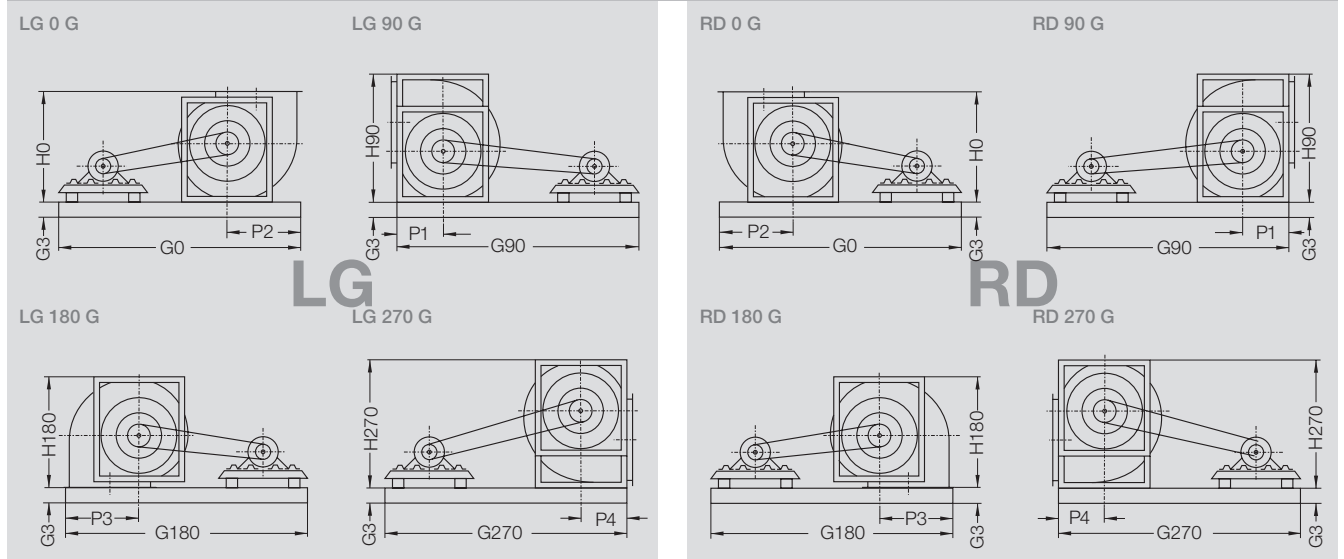

RZR	RZR		G0		G90		G180		G270		63-71	80-90	100-132	160-180	200-225	250-280
			CC②	U	CC②	U	CC②	U	CC②	U						
13-	18-	0400	1240	-	1300	-	1650	-	1240	-	82-CC	82-CC	82-CC	82-CC	80-U ③	-
13-	18-	0450	1300	-	1350	-	1740	-	1298	-	82-CC	82-CC	82-CC	82-CC	80-U ③	-
13-	18-	0500	1411	-	1411	-	1772	-	1411	-	82-CC	82-CC	82-CC	82-CC	80-U ③	-
13-	18-	0560	1468	-	1468	-	1908	-	1468	-	82-CC	82-CC	82-CC	82-CC	80-U ③	-
13-	18-	0630	1564	-	1564	-	2006	-	1564	-	82-CC	82-CC	82-CC	82-CC	80-U ③	-
13-	18-	0710	1660	1700	1660	1700	2145	2115	1660	1700	82-CC	82-CC	82-CC	100-U	120-U ③	-
13-	18-	0800	-	2300	-	2300	-	2885	-	2300	80-U	80-U	80-U	100-U	120-U	-
13-	18-	0900	-	2410	-	2410	-	3052	-	2410	80-U	80-U	80-U	100-U	120-U	-
13-	18-	1000	-	2505	-	2505	-	3180	-	2505	80-U	80-U	80-U	100-U	120-U	-

RZR	RZR		H0	H90	H180	H270	L2	P1	P2	P3	P4	X2	Motor Base frame ~ kg				
			max.	CC	80-U	100-U	120-U										
13-	18-	0400	671	775	671	775	170	290	290	669	290	550	225	31	③	③	③
13-	18-	0450	755	868	755	868	170	316	316	718	316	614	225	32	③	③	③
13-	18-	0500	827	957	827	957	170	345	345	766	345	682	225	33	60	-	-
13-	18-	0560	921	1083	921	1083	210	382	382	851	382	759	225	34	63	-	-
13-	18-	0630	1028	1204	1028	1204	210	410	410	915	410	846	225	35	68	-	-
13-	18-	0710	1152	1350	1152	1350	240	464	464	1014	464	943	250	37	94	155	-
13-	18-	0800	1290	1520	1290	1520	250	518	518	1155	518	1048	250	-	67	98	155
13-	18-	0900	1448	1707	1448	1707	260	570	570	1276	570	1179	280	-	72	105	165
13-	18-	1000	1577	1869	1577	1869	260	620	620	1317	620	1316	280	-	77	111	165

② The base frame length has been determined with the always largest admitted motor size. With smaller motors the frame length will be reduced.

③ Dimensions on request

For accurate dimensions use pro SELECTA II or on request.

# RZR 11-0800/-1000 RZR 15-0400/-1000

# RZR 19-0400/-1000

## Fan set arrangement with base frame

Dimensions in mm, subject to change.

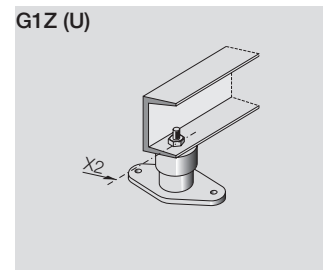
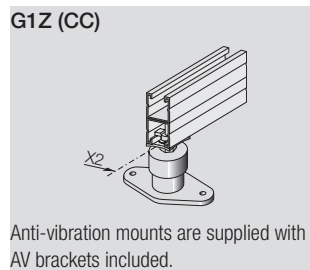
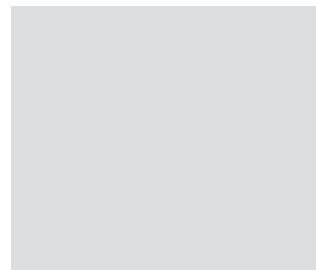
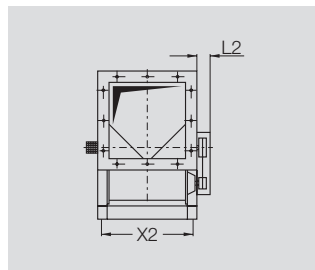
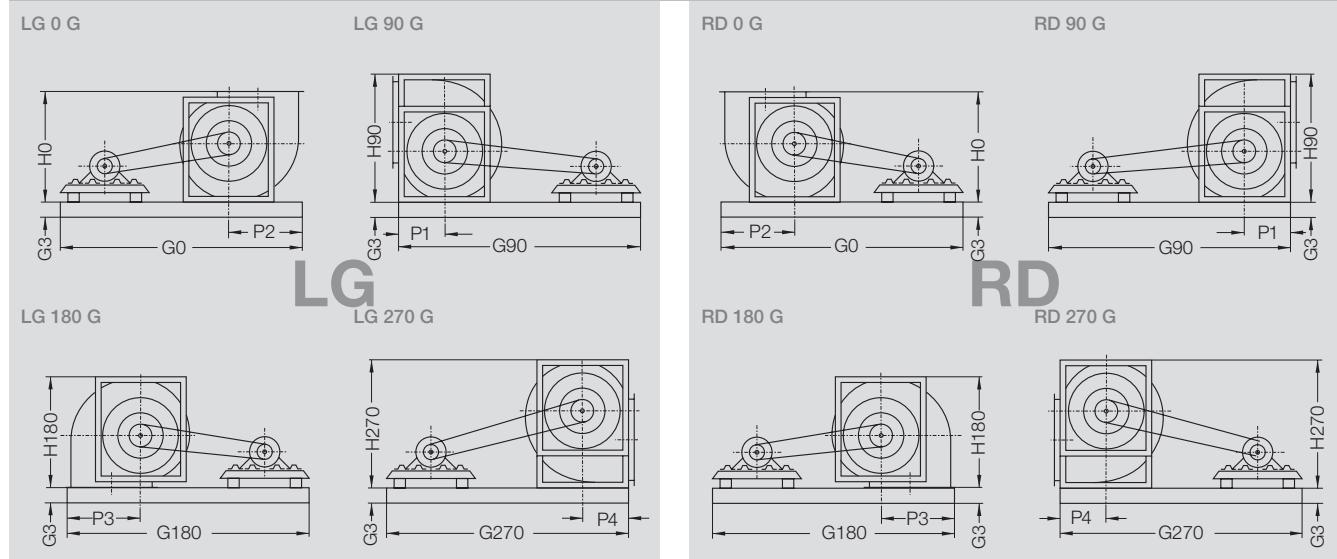

Anti-vibration mounts are supplied with AV brackets included.

RZR	RZR	RZR	G0	G90	G180	G270	63-71	80-90	100-132	160-180	200-225	250-280
			CC(2)	U	CC(2)	U						
15-	19-	0400	1240	-	1300	-	82-CC	82-CC	82-CC	82-CC	80-U (3)	-
15-	19-	0450	1300	-	1350	-	82-CC	82-CC	82-CC	82-CC	80-U (3)	-
15-	19-	0500	1411	-	1411	-	82-CC	82-CC	82-CC	82-CC	80-U (3)	-
15-	19-	0560	1468	-	1468	-	82-CC	82-CC	82-CC	82-CC	80-U (3)	-
15-	19-	0630	1564	-	1564	-		82-CC	82-CC	82-CC	80-U (3)	-
15-	19-	0710	1660	1700	1660	1700		82-CC	82-CC	82-CC	100-U	120-U (3)
11-	15-	19-	0800	2300	-	2300	-	80-U	80-U	80-U	100-U	120-U
11-	15-	19-	0900	2410	-	2410	-	80-U	80-U	80-U	100-U	120-U
11-	15-	19-	1000	2505	-	2505	-	80-U	80-U	80-U	100-U	120-U

RZR	RZR	RZR	H0	H90	H180	H270	L2	P1	P2	P3	P4	X2	Motor max.	Base frame ~ kg			
														CC	80-U	100-U	120-U
15-	19-	0400	671	775	671	775	170	290	290	669	290	550	225	31	(3)	(3)	(3)
15-	19-	0450	755	868	755	868	170	316	316	718	316	614	225	32	(3)	(3)	(3)
15-	19-	0500	827	957	827	957	170	345	345	766	345	682	225	33	60	-	-
15-	19-	0560	921	1083	921	1083	210	382	382	851	382	759	225	34	63	-	-
15-	19-	0630	1028	1204	1028	1204	210	410	410	915	410	846	225	35	68	-	-
15-	19-	0710	1152	1350	1152	1350	240	464	464	1014	464	943	250	37	94	155	-
11-	15-	19-	0800	1290	1520	1290	1520	250	518	518	1155	518	250	-	67	98	155
11-	15-	19-	0900	1444	1707	1444	1707	260	570	570	1276	570	280	-	72	105	165
11-	15-	19-	1000	1573	1869	1573	1869	260	620	620	1317	620	280	-	77	111	165

(2) The base frame length has been determined with the always largest admitted motor size. With smaller motors the frame length will be reduced.  
For accurate dimensions use pro SELECTA II or on request.

(3) Dimensions on request



# RZR 11-0200/-0710

# RZR 19-0200/-0355

## Fan set arrangement with Pick-A-Back

Dimensions in mm, subject to change.

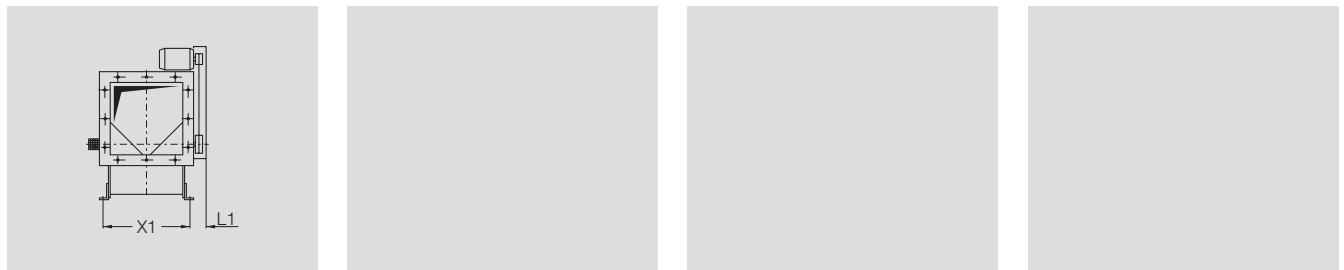
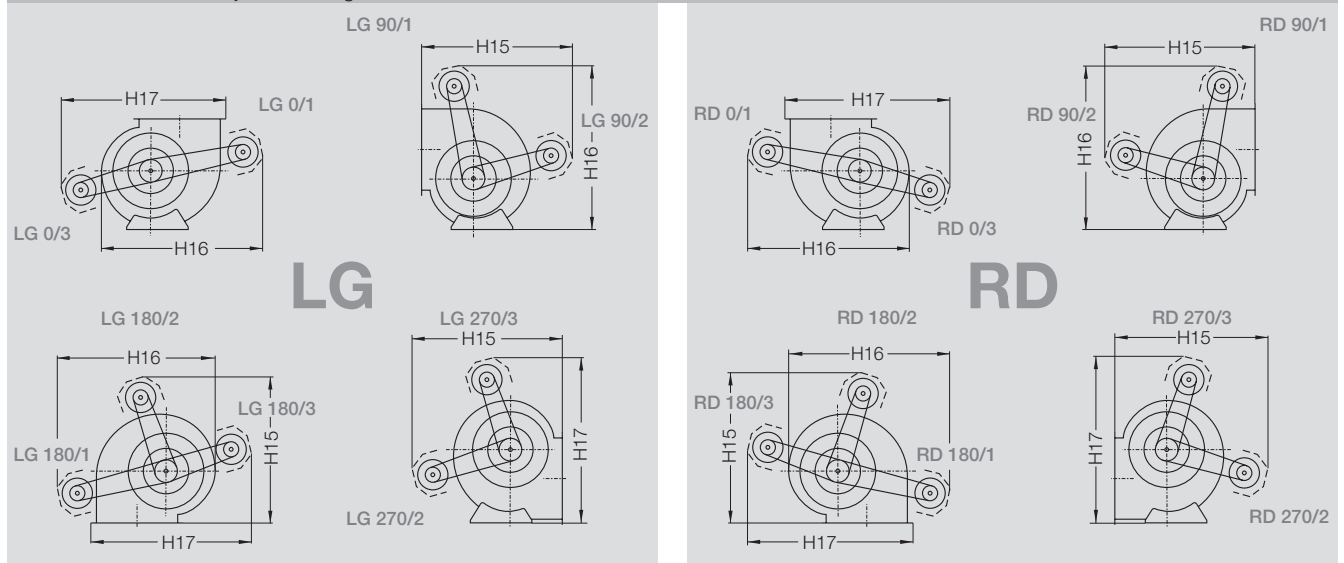

RZR	RZR		① ~ H15	① ~ H16	① ~ H17	L1	X1	Motor max.	Weight ~ kg
11-	19-	0200	650	720	680	100	286	90	1
11-	19-	0225	700	760	720	100	322	100	2
11-	19-	0250	750	850	810	100	356	100	2
11-	19-	0280	860	930	890	100	395	112	3
11-	19-	0315	880	970	960	100	438	112	3
11-	19-	0355	960	1080	1070	100	487	112	3
11-		0400	1280	1290	1280	120	546	132	8
11-		0450	1330	1430	1380	120	612	132	8
11-		0500	1360	1470	1560	120	680	132	8
11-		0560	1510	1630	1740	150	756	132	11
11-		0630	1660	1800	1820	150	843	160	12
11-		0710	1810	1960	2010	180	940	160	17

① This dimensions have been calculated with the largest appropriate applicable motor in mind.

Dimensions may be subject to chance.

# RZR 12-0200/-0710

## Fan set arrangement with Pick-A-Back

Dimensions in mm, subject to change.

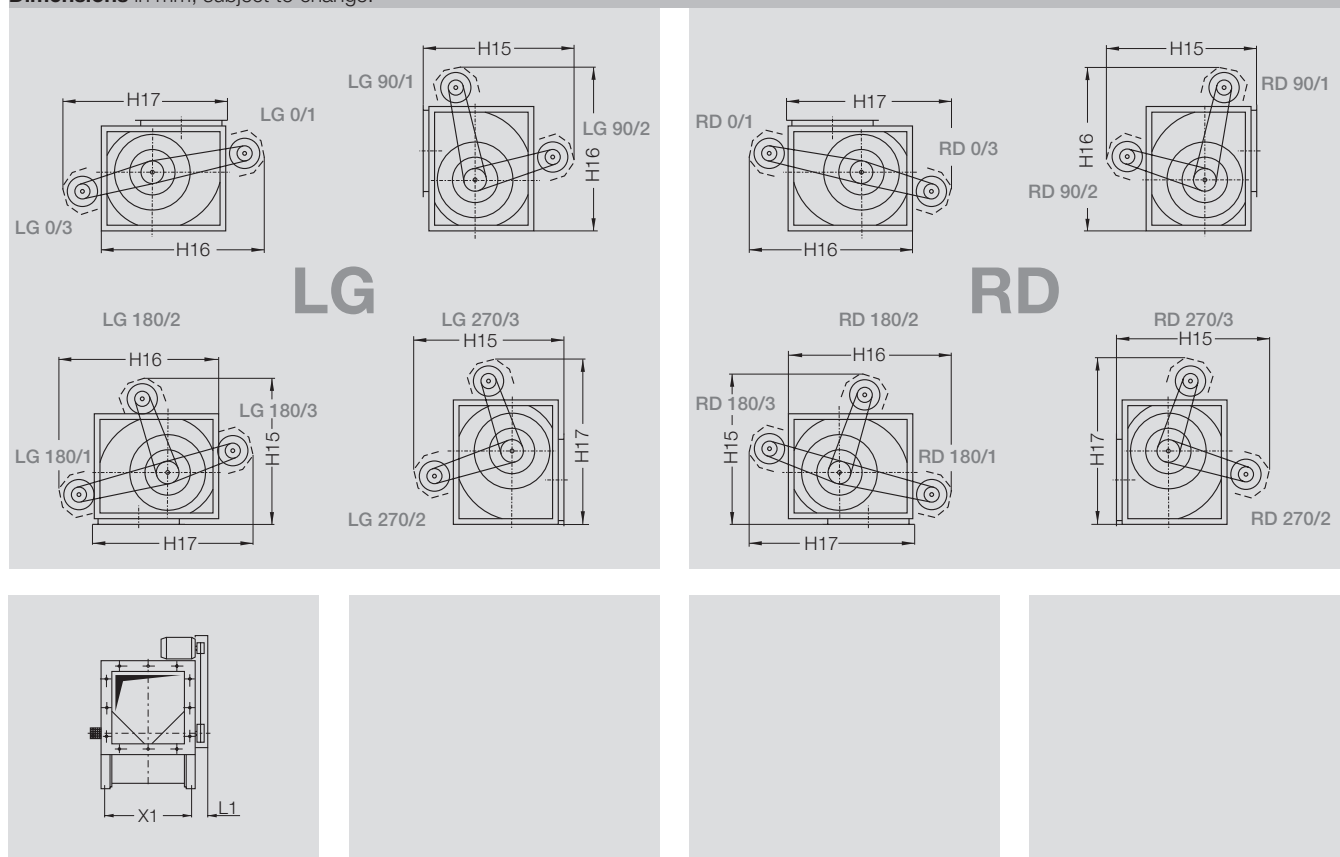

RZR		①	①	①	~ L1	X1	Motor	Weight
		~ H15	~ H16	~ H17			max.	~ kg
12-	0200	670	670	690	100	286	90	1
12-	0225	710	730	780	100	322	100	1
12-	0250	850	840	860	100	356	100	2
12-	0280	880	920	930	100	395	112	2
12-	0315	950	950	1030	100	438	112	3
12-	0355	1080	1090	1130	100	487	112	3
12-	0400	1190	1290	1280	120	546	132	7
12-	0450	1330	1430	1390	120	612	132	7
12-	0500	1360	1470	1560	120	680	132	8
12-	0560	1500	1620	1630	150	756	132	11
12-	0630	1650	1790	1810	150	843	160	12
12-	0710	1800	1950	2000	180	940	160	17

① This dimensions have been calculated with the largest appropriate applicable motor in mind.

Dimensions may be subject to chance.

# RZR 13-0400/-1000

# RZR 18-0400/-1000

## Fan set arrangement with Pick-A-Back

Dimensions in mm, subject to change.

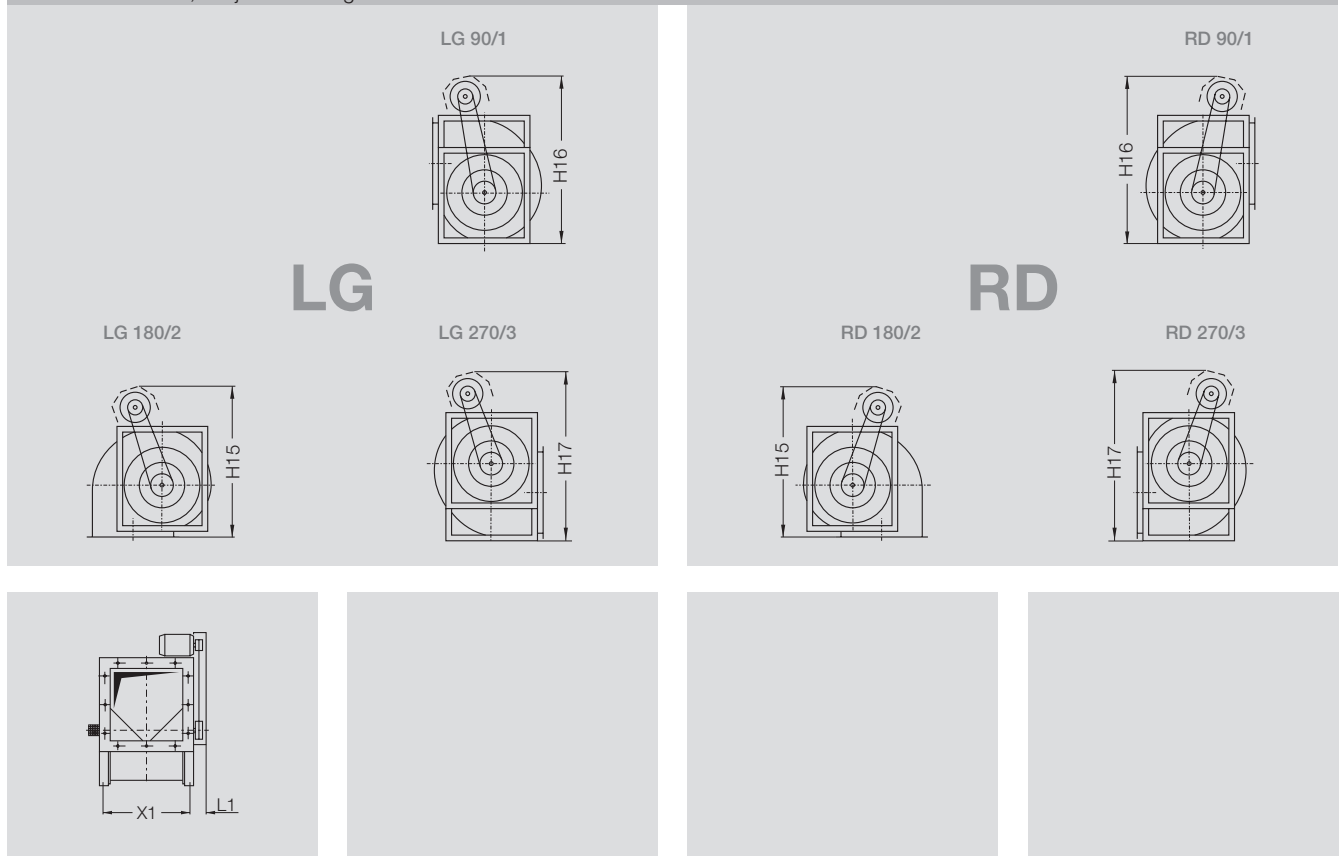

RZR	RZR	① ~ H15	① ~ H16	① ~ H17	~ L1	X1	Motor max.	Weight ~ kg
13-	18-	1280	1300	1300	170	548	132	10
13-	18-	1320	1430	1380	170	612	132	11
13-	18-	1350	1560	1550	170	683	132	12
13-	18-	1530	1700	1730	210	759	160	15
13-	18-	1640	1870	1820	210	845	160	16
13-	18-	1800	1970	2010	240	942	160	23
13-	18-	1970	2150	2150	250	1053	160	30
13-	18-	2150	2400	2350	260	1179	160	33
13-	18-	2230	2630	2550	260	1317	160	36

① This dimensions have been calculated with the largest appropriate applicable motor in mind.

Dimensions may be subject to chance.

**RZR 11-0800/-1000**  
**RZR 15-0400/-1000**

**RZR 19-0400/-1000**

**Fan set arrangement with Pick-A-Back**

Dimensions in mm, subject to change.

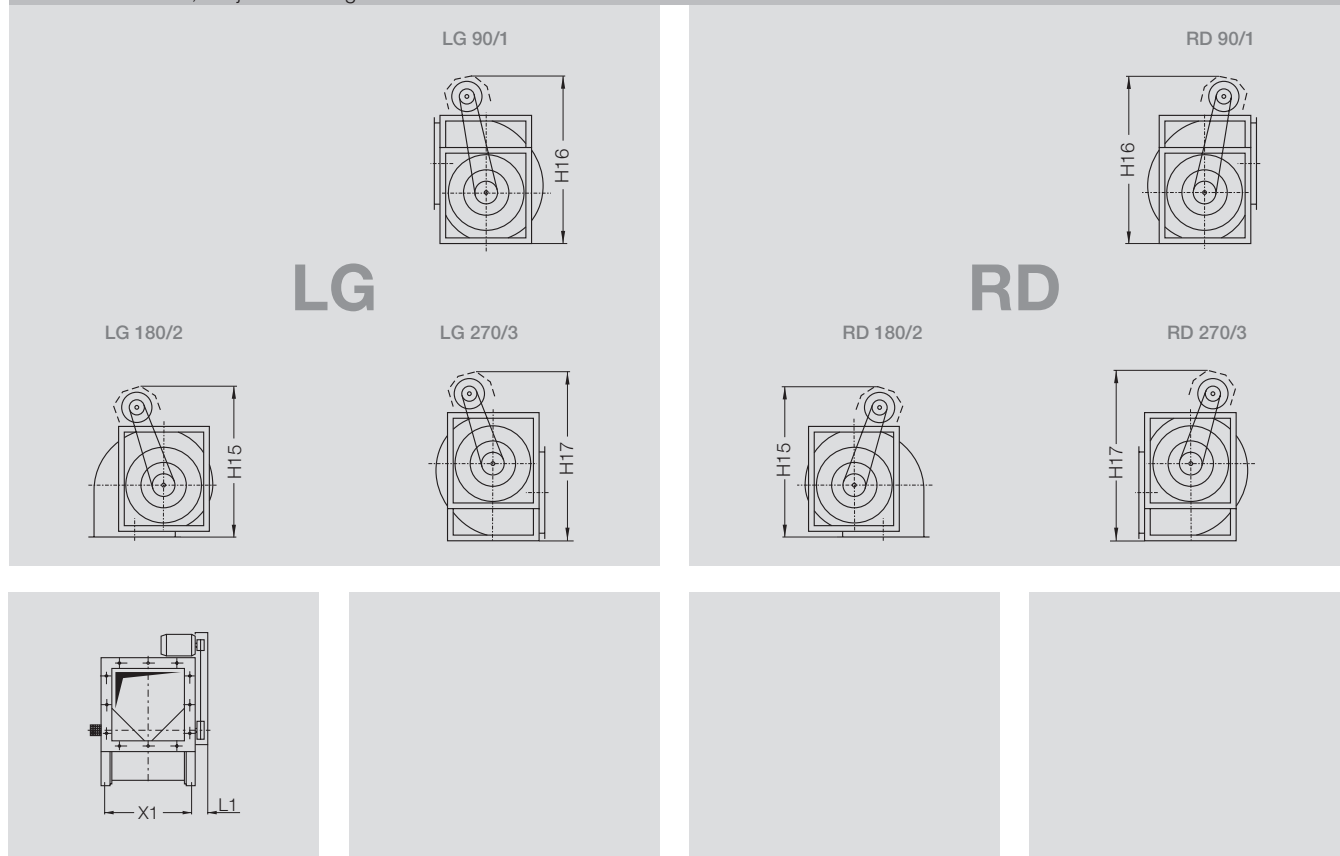

RZR	RZR	RZR	① ~ H15	① ~ H16	① ~ H17	~ L1	X1	Motor max.	Weight ~ kg
15-	19-	0400	1280	1300	1300	170	548	132	10
15-	19-	0450	1320	1430	1380	170	612	132	11
15-	19-	0500	1350	1560	1550	170	683	132	12
15-	19-	0560	1530	1700	1730	210	759	160	15
15-	19-	0630	1640	1870	1820	210	845	160	16
15-	19-	0710	1800	1970	2010	240	942	160	23
11-	15-	19-	0800	1970	2150	250	1053	160	30
11-	15-	19-	0900	2150	2400	260	1179	160	33
11-	15-	19-	1000	2230	2630	260	1317	160	36

① This dimensions have been calculated with the largest appropriate applicable motor in mind.

# Fan Sets

## Min. Pulley-Diameter, Bearings Life Expectancy

As a principle, the fans are only equipped with noise tested precision bearings designed for a nominal bearing life time (L10h acc. to DIN ISO 281-1) of 40 000 operating hours.

In order to not exceed the admitted bearing loads there are minimum pulley diameters defined to be respected when sizing the belt drive.

**The minimum pulley diameters indicated are to be applied for belt drives selected according to the state of the art and tensioned according to the prescriptions.**

**For flat belt drives the minimum pulley diameters are to be increased of 40% to the indicated figure!**

A correct design of a belt drive may be achieved with our selection software where all relevant parameters will be kept automatically.

For correct design of a belt drive made by external means, dimensioning and the application of the tensioning forces have to be made in full respect of all specification data indicated.

## Wedge Belts

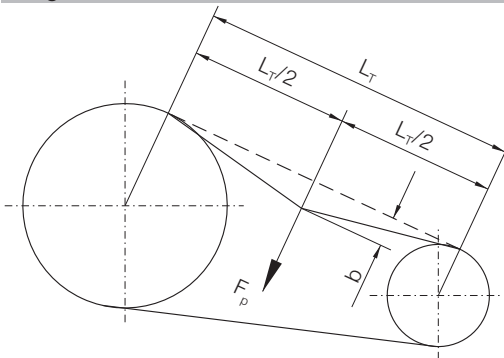

$L_T$  = Shaft Centres

$b$  = Deflection of belt in mm under test force  $F_p$

$F_p$  = Test force N as prescribed by Gebhardt-Documents

### Belt Tensioning

The correct tension is achieved when the test force  $F_p$  results in a deflection of 16 mm / metre of span.

## Flat Belts

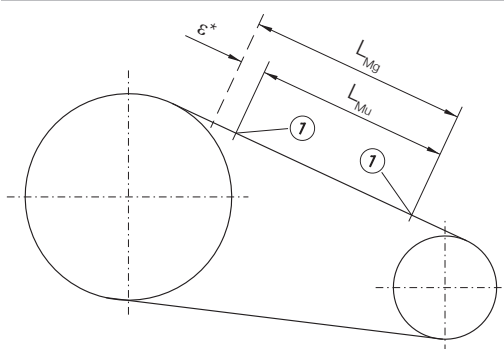

$L_{Mu}$  = Measuring Marks 1 before Tensioning

$L_{Mg}$  = Measuring Marks 1 After Tensioning

\* = Stretching Values as specified by Gebhardt-Documents

### Belt Tensioning

The correct belt tension is achieved when the measuring marks  $L_{Mu}$  have increased by the stretching value  $e^*$ . This should be carried out in two stages to prevent overstressing of the bearing.

## Wedge- and Flat Belts

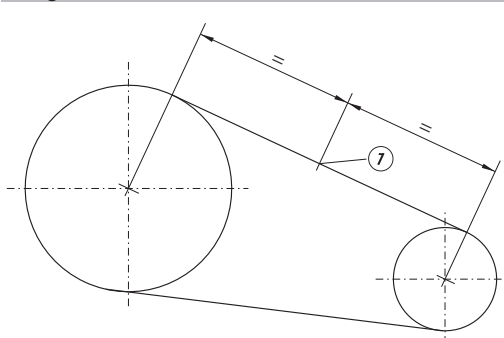

A further simple method for setting or checking the correct belt tension is via the static frequency of the drive belt.

Here the flat or V-belt is set to oscillate freely through striking it whilst stationary.

These vibrations are measured using an electronic measuring unit (e.g. a belt tension gauge). The vibration frequency in Hz must then be set to the specified value (documentation / nameplate).

[1] = Measuring point

**Detailed instruction on tensioning are included within the operating and maintenance manuals.**

# Fan Sets

Min. recommended Pulley Diameter for ADH														
Fan site	Fan model	Nominal motor power in kW												
		2.2	3	4	5.5	7.5	11	15	18.5	22	30	37	45	55
160	E0 / E2	63	71											
	G2E0 / E2	63	71											
180	E0 / E2	63	80											
	G2E0 / E2	63	80											
200	E0 / E2 / E4	71	95	125										
	G2E0 / E2	71	95	140										
225	E0 / E2 / E4	80	112	140										
	G2E0 / E2	80	100	160										
250	E0 / E2	80	112	150										
	E4		90	112	140	180								
	G2E0 / E2	80	100	132										
	G2E4		95	125	160	224								
280	G2E7					100	118	160						
	E0 / E2		100	140	180									
	E4			90	112	140	212							
	G2E0 / E2		112	140	180									
315	G2E4			100	118	150	224							
	G2E7					112	112	140	180	224				
	E0 / E2		100	125	180									
	E4			90	125	160	250							
355	E6						160	224	250					
	G2E0 / E2		112	140	200									
	G2E4			112	140	180	250							
	G2E7							160	190	212	300			
400	E0 / E2			100	132	180								
	E4				112	150	224	280						
	E6						125	180	224	236				
	G2E0 / E2		112	140	200									
450	G2E4				112	150	224	280						
	G2E7							160	180	212	300			
	E0 / E2			100	132	180								
	E4				112	150	224	280						
500	E6						140	180	212	250				
	E7								150	190	224	315		
	G2E0 / E2			118	140	200								
	G2E4				112	160	224							
560	G2E7								180	212	250	300		
	E0 / E2				132	180	224							
	E4					150	200	236						
	E6							160	190	250				
630	E7								160	180	212	236		
	G2E2					132	180	212						
	G2E4					132	180	224						
	G2E7								160	224	250	280		
710	L / R					132	160	215						
	K						132	200	224					
	K1								160	180	250			
	K2									160	180	200	224	
800	G2R					132	180	200						
	G2K						132	180	224					
	G2K2									180	224	280	355	
	L / R					132	150	180	250					
900	K						132	180	224	250				
	K1									180	212	236		
	K2										180	200	224	280
	G2K									160	190	212		
1000	G2K2										180	200	224	280
	K								160	180	224	250		
	K1										212	236	280	
	K2											200	224	280

# Fan Sets

Min. recommended Pulley Diameter for AT																		
Fan site	Fan model	Nominal motor power in kW																
		1.1	1.5	2.2	3	4	5.5	7.5	11	15	18.5	22	30	37	45	55		
7/7	S / SC	63	63	80	112													
	G2L / SC2	63	63	90	118													
9/7	S / SC	63	63	85	112													
	AR	-	-	-	80	100	140	200										
	G2L / SC2	63	63	90	125													
9/9	G2C	-	-	-	71	80	100	150										
	S / SC	-	63	90	125													
	AR	-	-	-	85	112	150	224										
10/8	G2L / SC2	63	71	95	132													
	G2C	-	-	-	-	80	112	150										
	S / SC	63	71	85	112													
10/10	AR	-	-	-	80	100	150	200										
	G2L / SC2	63	80	112	140													
	G2C	-	-	-	-	90	125	180										
12/9	S / SC	-	-	71	90	118	180											
	AR	-	-	-	-	85	118	160	236									
	G2L / SC2	-	-	85	95	118	180											
	G2C	-	-	-	-	80	90	118	224									
12/12	G3C	-	-	-	-	100	112	118	180									
	S / SC	-	-	90	112	140	200											
	AR	-	-	-	-	100	140	190	280									
	G2L / SC2	-	-	80	112	140	200											
15/11	G2C	-	-	-	-	85	112	140	200									
	G3C	-	-	-	-	90	112	140	200									
	S / SC	-	-	85	112	132	180											
	AR	-	-	-	-	90	118	160	236									
15/15	G2L / SC2	-	-	80	100	140	200											
	G2C	-	-	-	-	85	100	132	200									
	G3C	-	-	-	-	100	118	160	224									
	S / SC	-	-	80	100	132	180											
18/13	AR	-	-	-	-	95	132	180	250									
	G2L / SC2	-	-	-	95	125	180	250										
	G2C	-	-	-	-	95	112	160	224									
	G3C	-	-	-	-	100	112	160	224									
18/18	S / SC	-	-	-	100	132	180	250										
	AR	-	-	-	-	100	132	190	280									
	G2L / SC2	-	-	-	90	118	180	224										
	G2C	-	-	-	-	95	112	160	224									
20/15	G3C	-	-	-	-	100	112	140	200									
	G3C-C2	-	-	-	-	-	-	-	-	112	150	200	280					
	TIC	-	-	-	-	-	-	-	-	100	140	200	280					
	G2C	-	-	-	-	-	-	-	-	112	160	250	280					
20/20	G2C-C2	-	-	-	-	-	-	-	-	-	-	-	-	150	180	200	224	
	G3C	-	-	-	-	-	-	-	-	112	140	200	250					
	G3C-C2	-	-	-	-	-	-	-	-	-	-	-	-	150	180	200	224	
	TIC	-	-	-	-	-	-	-	-	100	132	200	280					
22/15	G2C	-	-	-	-	-	-	-	-	112	160	224	280					
	G2C-C2	-	-	-	-	-	-	-	-	-	-	-	-	150	180	200	224	
	G3C	-	-	-	-	-	-	-	-	112	140	200	250					
	G3C-C2	-	-	-	-	-	-	-	-	-	-	-	-	150	180	200	224	
22/22	TIC	-	-	-	-	-	-	-	-	100	132	200	280					
	G2C	-	-	-	-	-	-	-	-	112	150	224	280					
	G2C-C2	-	-	-	-	-	-	-	-	-	-	-	-	150	180	200	224	
	G3C	-	-	-	-	-	-	-	-	112	140	200	250					
25/20	G3C-C2	-	-	-	-	-	-	-	-	-	-	-	-	150	180	190	224	
	TIC	-	-	-	-	-	-	-	-	90	118	160	224					
	G2C	-	-	-	-	-	-	-	-	112	140	200						
	G2C-C2	-	-	-	-	-	-	-	-	-	-	-	-	250	150	180	190	224
25/25	G3C	-	-	-	-	-	-	-	-	112	132	200	224					
	G3C-C2	-	-	-	-	-	-	-	-	-	-	-	-	224	150	180	190	224
	TIC	-	-	-	-	-	-	-	-	112	150	224	250					
	G2C	-	-	-	-	-	-	-	-	112	140	200	250					
28/20	G2C-C2	-	-	-	-	-	-	-	-	-	-	-	-	150	180	190	224	224
	G3C	-	-	-	-	-	-	-	-	112	132	180	224					
	G3C-C2	-	-	-	-	-	-	-	-	-	-	-	-	150	180	190	224	224
	TIC	-	-	-	-	-	-	-	-	100	140	200	250					
28/28	G2C	-	-	-	-	-	-	-	-	112	132	180	224					
	G2C-C2	-	-	-	-	-	-	-	-	-	-	-	-	150	180	190	224	224
	G3C	-	-	-	-	-	-	-	-	112	125	160	200					
	G3C-C2	-	-	-	-	-	-	-	-	-	-	-	-	150	180	190	224	224
30/20	TIC	-	-	-	-	-	-	-	-	100	140	200	250					
	G2C	-	-	-	-	-	-	-	-	100	132	180	224					
	G2C-C2	-	-	-	-	-	-	-	-	-	-	-	-	150	180	190	212	224
	G3C	-	-	-	-	-	-	-	-	100	125	180	224					
30/28	G3C-C2	-	-	-	-	-	-	-	-	-	-	-	-	150	180	190	224	224
	TIC	-	-	-	-	-	-	-	-	100	140	200	250					
	G2C	-	-	-	-	-	-	-	-	100	125	180	224					
	G2C-C2	-	-	-	-	-	-	-	-	-	-	-	-	150	180	190	212	224

# Fan Sets

Min. recommended Pulley Diameter for RDH														
Fan site	Fan model	Nominal motor power in kW												
		2.2	3	4	5.5	7.5	11	15	18.5	22	30	37	45	55
0180	E0 / E2	63	63											
0200	E0 / E2 / E4	63	63											
0225	E0 / E2 / E4	63	63	71										
0250	E0 / E2		71	80										
	E4		71	71	90									
	G2E4		80	80	90									
	G2E7				85	112								
0280	E0 / E2			80	100									
	E4				90	100								
	G2E0 / E2													
	G2E4			90	100									
0315	G2E7					90	125							
	E0 / E2			90	118									
	E4				90	112								
	E6					90	100							
0355	G2E0 / E2													
	G2E4			80	90									
	G2E7					90	112							
	E0 / E2			85	100	112								
0400	E4				90	112	125							
	E6					100	112	118						
	G2E0 / E2													
	G2E4			90	125									
0450	G2E7					90	112							
	E0 / E2				112	140								
	E4					100	132	180						
	E6						118	140	150					
0500	G2E4			100	112	112								
	G2E7					112	125	160						
	E0 / E2				125	132	160	200						
	E4					132	150	200						
0560	E6						140	140	150	200				
	E7							118	125	150	200			
	G2E4				100	118	150							
	G2E7							140	150	180				
	E0 / E2					140	180	224						
	E4						150	200	224					
0630	E6							150	160	212				
	E7								140	160	160			
	G2E2													
	G2E4					112	140							
	G2E7							180	200	280				
	R					140	180	250						
0710	K						150	200	250					
	K1							180	180	236				
	K2								150	180	190	224		
	G2K						140	190						
	G2K2								180	200	280	355		
	R						180	224						
0800	K							224	250	315				
	K1								180	224	250			
	K2									200	212	224		
	G2K								180	200	280			
	G2K2											224	224	280
0900	K								200	250	280			
	K1									212	250	280		
	K2										224	224	280	
	G2K								180	190	250			
1000	G2K2											224	250	280
	K								160	180	250			
	K1									212	250	280		
	K2										224	224	280	



# Fan Sets

Min. recommended Pulley Diameter for RZR																				
Fan site	Fan model	Nominal motor power in kW																		
		3	4	5.5	7.5	11	15	18.5	22	30	37	45	55	75	90	110	132	160	200	250
0200	11 / 12 / 19	71	71	71	90															
0225	11 / 12 / 19	71	71	80	100															
0250	11 / 12 / 19	71	71	90	112															
0280	11 / 12	71	71	90	118															
	19	71	71	71	85	112														
0315	11 / 12	71	85	106	132															
	14	71	71	75	95	132														
	19	71	71	75	95	125														
0355	11 / 12	75	95	118	150															
	14	71	71	71	80	112														
	19	71	71	85	106	140														
0400	11 / 12	71	80	100	125															
	14	71	71	75	100	132	160													
	13 / 15 / 18 / 19	71	71	71	71	85	106	125	140	180										
0450	11 / 12	71	90	112	140															
	14	71	71	71	85	118	150													
	13 / 15 / 18 / 19	71	71	71	71	95	118	140	160	200										
0500	11 / 12	80	100	125	160															
	14	71	71	75	100	132	170													
	13 / 15 / 18 / 19	71	71	71	80	106	132	160	180	224										
0560	11 / 12	71	71	85	112	150	190													
	14	71	71	85	106	150	180	212	250											
	13 / 15 / 18 / 19	71	71	71	71	90	112	132	150	190	224									
0630	11 / 12	71	80	100	132	180	224													
	14	71	75	95	125	170	212	250	280											
	13 / 15 / 18 / 19	71	71	71	75	100	125	150	170	224	250									
0710	11 / 12	71	85	112	140	190	236	280												
	14	71	85	112	140	190	250	280	315											
	13 / 15 / 18 / 19	71	71	71	71	85	106	118	140	180	212	250	280							
0800	11	80	100	125	160	224	280	315	355											
	14	80	100	125	160	224	280	335	375											
	13 / 15 / 18 / 19	71	71	71	71	95	118	140	160	212	236	280	315							
0900	11	95	118	150	200	280	355	400	450											
	14	71	75	95	125	170	212	250	280	375	425									
	13 / 15 / 18 / 19	71	71	71	71	85	106	125	140	180	212	250	300	375						
1000	11	112	140	180	224	315	400	450	500											
	14	71	85	106	140	190	236	280	315	425	500									
	13 / 15 / 18 / 19	71	71	71	71	95	118	140	160	212	236	280	315	425						
1120	13	-	-	-	-	315	315	315	315	315	315	315	315	355	355	400	450			
1250	13	-	-	-	-	315	315	315	315	315	315	315	315	355	355	400	400	450		
1400	13	-	-	-	-	315	315	315	315	315	315	315	315	355	355	400	400	450	450	
1600	13	-	-	-	-	315	315	315	315	315	315	315	315	355	355	400	400	450	500	560

For flat-belt-drives the listed recommended pulley diameter must be enlarged up to approx. 40%.

# Description

## General

The high-performance centrifugal fans are the result of extensive and systematic development work. These technically first-rate products are distinguished by their high efficiency, the large pressure differences attainable and low noise levels. The sizes are geometrically scaled in accordance with the standard range R 20 and the nominal size stated is the external diameter of the impeller.

## Media



The fans are suitable for handling air and other non aggressive gases from -20°C up to +80°C, resp. +100°C. The ambient temperature at the drive motor must not exceed +40°C.

## Protective installations



The fans are designed for installation in equipment and as standard are not equipped with protective guards.

**They should not be put into operation before all protective devices are fitted and connected!**

Protective measures must be carried out as set out in DIN EN ISO 12 100 "Safety of machinery - Basic concepts, general principles for design".

If the application of the fan allows free access to the inlet and discharge apertures, safety devices must be put in place on the fan in accordance with DIN EN ISO 13857! Suitable safety guards are available as an optional extra.

## Shafts

### Shafts ADH/AT/RDH



The fan shafts are manufactured of ground, precisely rounded carbon steel C40. They are principally prepared without being stepped at both ends.

The shafts of the RDH K1 and K2 ranges, size 1000, as well as RDH X1 and RDH X2 sizes 1120 to 1400 are machined on both ends for fitting a pulley.

ADH / RDH / AT from size 12-9

The shafts are equipped with a keyway (open shape) at both ends and a key (type 2). AT 7-7 up to 10-10

The standard construction is the version with flats on shaft ends (type 1), it is also available the version with keyways (type 2).

For corrosion protection the shafts are galvanised up to fan size 0560 / 30-28.

From size 0630 and larger the shaft are covered, between bearing and hub, with a paint in order to ensure corrosion protection.

The shaft ends are covered with a wax product easy to remove.

### Shafts RZR



The shafts are manufactured of precisely rounded carbon steel C35, pared and polished.

Up to size 1000 they are not stepped at the shaft end.

For sizes 1120 up to 1600 the shafts are machined on both ends for fitting a pulley.

The shafts are equipped with a keyway at both ends and a key executed according to DIN 6885-1

- Groove shape N2 (open) Sizes 0200 up to 1000
- Groove shape N1 Sizes 1120 up to 1600

The shafts are covered with a easily removable wax product for corrosion protection.

### ADH / AT / RDH - Housig feet / Side frames



For easier installation of the fan the mounting feet and reinforcing frames are provided with eye holes.

# Description

## Bearings ADH/AT/RDH



**ADH E0 / ADH L**  
**ADH E2 / ADH R**  
**AT S / AT SC**  
**AT G2L / AT SC2**  
**RDH E0**  
**RDH E2 / RDH R**

Maintenance free, self aligning radial insert ball bearings, mounted in pressed steel housing/strut assemblies with rubber interliners.

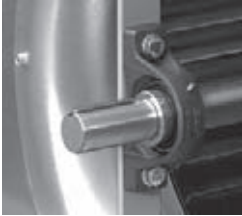

**ADH E4 / ADH K**  
**AT AR / AT TIC / AT G2C**  
**RDH E4 / RDH K**

Monobloc pedestal cast iron pillow block bearings with relubrication nipple, mounted on a robust frame.

Integrated, maintenance free self aligning radial ball bearings, fixed by eccentric clamp.



**ADH E6 / ADH K1 / ADH E7-0500**  
**RDH E6 / RDH K1 / RDH E7-0500**

Pillow block cast iron bearings with relubrication nipple, mounted on a robust frame. Integrated self aligning radial ball bearings, fixed by conical sleeve and locknut.



**ADH E7-0560; ADH K2-0630/-0800**  
**AT G2C-C2**  
**RDH E7-0560; RDH K2-0630/-0800**

Split-type plummer block bearings with relubrication nipple, mounted on a robust frame, integrated self aligning double row ball-bearings fixed by conical sleeve, lubricated with long life high performance grease.

**ADH K2-0900-1000 / RDH K2-0900-1000**  
**RDH X1 / RDH X2**

Single piece plummer block housing, with grease nipple, mounted on robust pedestal, equipped with self aligning double row roller bearing, fixed to impeller shaft by a concentric shaft clamp, lubricated with long life high performance grease.

### Twin Fans

The twin fans up to size 0630 are equipped with one single shaft and 3 bearings. From size 0710 the two separate fans are connected by an elastic coupling. For the models G2K2 the bearings from size 0710 and larger are – due to different loads – of a different execution inside compared to outside.

# Description

## Bearings RZR



**RZR 11-0200/-1000; RZR 12-0200/-0710** (without relubricators)  
Radial insert ball bearings with spherical outer Ring mounted in pressed steel housing/strut assemblies with rubber interliners.

**RZR 11-0200/-0710; RZR 12-0200/-0710** (with relubricators)  
Radial insert ball bearings with spherical outer Ring mounted within cast iron housing, supported from the fan casing by tubular struts.  
Relubrication is effected via extended tubes and nipples.

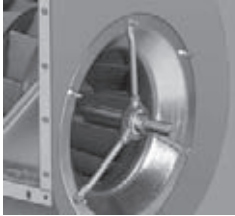

**RZR 19-0200/-0355** (without lubricators)

Radial insert ball bearings with spherical outer Ring mounted within cast iron housing, supported from the fan casing by tubular struts.

**RZR 19-0200/-0355** (with lubricators)  
Relubrication is effected via extended tubes and nipples.



**RZR 15-0400/-1000; RZR 19-0400/-1000** (without lubricators)

Self aligning double row ball bearings secured by adapter sleeve, mounted within a cast iron housing.

**RZR 15-0400/-1000; RZR 19-0400/-1000** (with lubricators)  
Relubrication is effected via extended tubes and nipples.

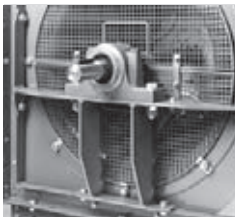

**RZR 13-0400/-1600; RZR 18-0400/-1000** (without lubricators)

Self aligning double row ball bearings within standard plummer blocks, mounted on robust pedestal.

**RZR 13-0400/-1600; RZR 18-0400/-1000** (with lubricators)  
Relubrication is effected via extended tubes and nipples.

### Lubricators for relubrication during operation

The Bearings are charged with long life high performance grease. Relubrication is effected via extended tubes and nipples.  
See operating and maintenance instructions.

- **IWN 01** - uses standard grease
- **IWN 11** - uses moisture resistant grease

# Description

## Motors



Standard motors of wellknown brands, type of protection IP55, thermal class F, are used. During commissioning and maintenance the detailed instructions provided by the motor manufacturer (type plate/motor operating instructions) must be followed, this also applies to the motor protection devices required onsite. The motors are equipped with PTC resistors/temperature sensors as standard. Motors with integrated frequency inverters may be supplied on request.

### EX-ATEX motors

Fan sets of centrifugal fans according to Ex-ATEX execution are equipped with motors of the correspondent category.

For frequency inverter operation the motors will be of pressure resistant execution.

### Speed regulation

A suitable speed variation system is required for the optimum adjustment of the desired operating point.

Our frequency converters are perfectly tuned for the operation of *rotavent* centrifugal fans.

The use of the newest power semi-conductors guarantees high efficiency and minimum motor noise thanks to the especially fine pulse pattern.

See also the technical description "Performance".

### Electric connection

Centrifugal fan systems are delivered ready for installation. The motor terminal box can be easily accessed.

Electric installation must be carried out according to the applicable provisions in compliance with local regulations. A terminal board circuit diagram showing correct connection is enclosed with every motor.

## Attachment points on the side plates ADH/RDH ADH/RDH 0160/-0180

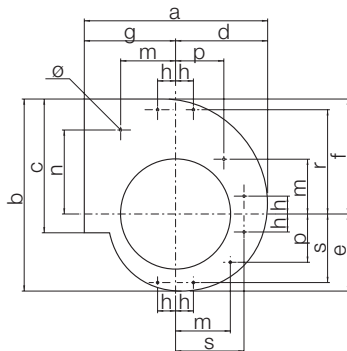

	a	b	c	d	e	f	g	h	m	n	p	r	s	ø
0160	281	291	205	141	119	172	140	30	92	121	67	155	101	4
0180	310	326	229	157	131	195	153	30	92	141	81	175	115	4

## ADH/RDH 0200/-0250

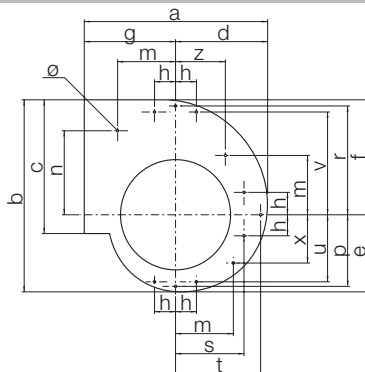

	a	b	c	d	e	f	g	h	m	n
0200	341	362	256	177	147	215	164	40	110	155
0225	379	407	288	199	165	242	180	40	110	184
0250	416	452.5	322	221	183.5	269	195	40	110	209

	p	r	s	t	u	v	z	x	ø
0200	134	202	129	163	126	190	94	91	4
0225	152	229	149	185	142	219	114	107	4
0250	171	256	172	208	155	244	137	120	4

# Description

## Attachment points on the side plates ADH/RDH

### ADH/RDH 0280/-0315

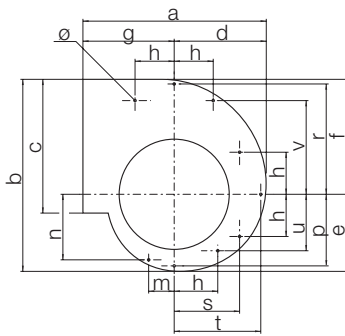

	a	b	c	d	e	f	g	h	m	n	p	r	s	t	u	v	ø
0280	464	508	361	249	206	302	215	113	71	170	191	287	169	233	150	245	6.2
0315	515	571	404	279	232	339	236	113	71	195	215	323	197	263	175	284	6.2

### ADH/RDH 0355/-0450

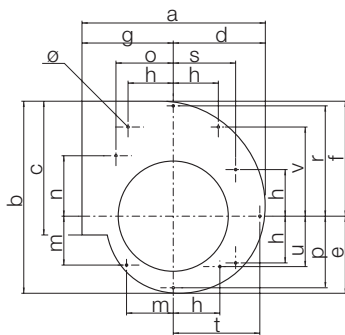

	a	b	c	d	e	f	g	h	m
0355	576	643	453	315	261	382	261	156	158
0400	644	733	507	354	302	431	290	156	186
0450	721	817.5	569	399	332.5	485	322	213	168

	n	o	p	r	s	t	u	v	ø
0355	197.5	197.5	241	364	204	295	158	295	6.2
0400	220	230	275	411	243	336	186	346	6.2
0450	245	256	311	466	271	379	168	350	M10

### ADH/RDH 0500

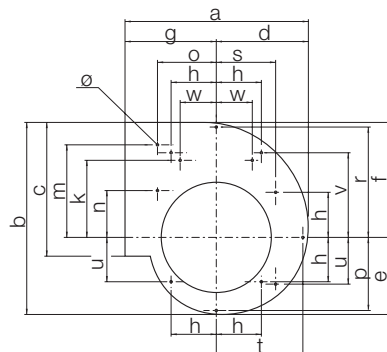

	a	b	c	d	e	f	g	h	m	n
0500	794	906	638	442	368	538	352	231	439	220

	o	p	r	s	t	u	v	k	w	ø
0500	281	349	519	280	423	207	400	354	181	M10

### ADH/RDH 0560/-0710

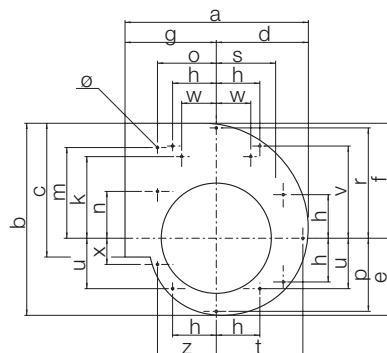

	a	b	c	d	e	f	g	h	m	n	o
0560	886	1016	715	496	413	603	390	235	490	245	310
0630	993	1142	801	559	463	679	434	235	553.5	260	353
0710	1119	1295	898	634	530	765	485	265	626.5	267.5	393

	p	r	s	t	u	v	z	x	k	w	ø
0560	389	581	362	472	276	494	310	140	394	180	M10
0630	441	656	431	521	328	567	356	160	–	–	M10
0710	496	737	476	605	371	637	397	200	–	–	M10

### Screw to be used to attach mounting feet

Size	Type of screw	Thread
0160/-0250	Self-threading screw	AB 6.3 ISO 1478
0280/-0400	Self-threading screw	AB 8 ISO 1478
0450/-0710	Metric screw	M10 ISO 724

# Description

## Operating limits ADH

ADH	Permissible nominal motor power kW	Permissible fan speed 1/min	Permissible bearing load N	Permissible media temperature °C	Fan weight kg	ADH	Permissible nominal motor power kW	Permissible fan speed 1/min	Permissible bearing load N	Permissible media temperature °C	Fan weight kg
E0-0160	3	4200	420	-20 / +80	5	E0-0500	11	1200	1180	-20 / +80	57
E2-0160	3	4200	420	-20 / +80	6.6	E2-0500	11	1200	1180	-20 / +80	65
G2E0-0160	3	3400	420	-20 / +80	10.5	E4-0500	15	1300	1320	-20 / +100	85
G2E2-0160	4	3400	420	-20 / +80	14.5	E6-0500	30	1400	1800	-20 / +100	86
E0-0180	3	4000	420	-20 / +80	6	E7-0500	37	1400	2200	-20 / +100	105
E2-0180	3	4000	420	-20 / +80	7.8	G2E0-0500	11	900	1180	-20 / +80	120
G2E0-0180	3	3200	420	-20 / +80	12.6	G2E2-0500	11	900	1180	-20 / +80	140
G2E2-0180	4	3200	420	-20 / +80	17	G2E4-0500	15	1000	1320	-20 / +100	176
E0-0200	4	3800	420	-20 / +80	7.1	G2E7-0500	45	1400	4000	-20 / +100	221
E2-0200	4	3800	420	-20 / +80	9.1	E0-0560	15	1100	1450	-20 / +80	72
E4-0200	4	3800	420	-20 / +100	12.6	E2-0560	15	1100	1450	-20 / +80	86
G2E0-0200	4	2900	420	-20 / +80	15	E4-0560	18.5	1200	1760	-20 / +100	134
G2E2-0200	4	2900	420	-20 / +80	20	E6-0560	30	1300	2550	-20 / +100	142
E0-0225	4	3400	420	-20 / +80	8.5	E7-0560	45	1300	3700	-20 / +100	150
E2-0225	4	3400	420	-20 / +80	10.7	G2E2-0560	15	800	1450	-20 / +80	185
E4-0225	4	3400	420	-20 / +100	14.5	G2E4-0560	18.5	900	1760	-20 / +100	268
G2E0-0225	4	2600	420	-20 / +80	18	G2E7-0560	45	1200	4000	-20 / +100	319
G2E2-0225	4	2600	420	-20 / +80	24	L-0630	15	900	1450	-20 / +80	91
E0-0250	4	2800	420	-20 / +80	10.5	R-0630	15	900	1450	-20 / +80	106
E2-0250	4	2800	420	-20 / +80	13	K-0630	18.5	1000	1760	-20 / +100	170
E4-0250	7.5	3000	450	-20 / +100	18	K1-0630	30	1100	2550	-20 / +100	175
G2E0-0250	4	2200	420	-20 / +80	22	K2-0630	45	1100	3700	-20 / +100	180
G2E2-0250	4	2200	420	-20 / +80	29	G2R-0630	15	700	1450	-20 / +80	230
G2E4-0250	7.5	2300	450	-20 / +100	38	G2K-0630	18.5	750	1760	-20 / +100	342
G2E7-0250	15	2800	1250	-20 / +100	44	G2K2-0630	55	1000	4000	-20 / +100	393
E0-0280	5.5	2500	530	-20 / +80	14.2	L-0710	18.5	750	1800	-20 / +80	118
E2-0280	5.5	2500	530	-20 / +80	18	R-0710	18.5	750	1800	-20 / +80	135
E4-0280	11	2700	660	-20 / +100	24	K-0710	22	850	1900	-20 / +100	201
G2E0-0280	5.5	2000	530	-20 / +80	30	K1-0710	37	900	3550	-20 / +100	208
G2E2-0280	5.5	2000	530	-20 / +80	39	K2-0710	55	900	5800	-20 / +100	225
G2E4-0280	11	2200	660	-20 / +100	50	G2K-0710	30	700	3000	-20 / +100	532
G2E7-0280	22	2400	1700	-20 / +100	59	G2K2-0710	75	800	7000	-20 / +100	537
E0-0315	5.5	2100	530	-20 / +80	18	K-0800	22	750	1900	-20 / +100	249
E2-0315	5.5	2100	530	-20 / +80	22	K1-0800	37	800	3550	-20 / +100	261
E4-0315	11	2400	660	-20 / +100	29	K2-0800	55	800	5800	-20 / +100	278
E6-0315	18.5	2400	1050	-20 / +100	30	G2K-0800	30	600	3000	-20 / +100	665
G2E0-0315	5.5	1600	530	-20 / +80	38	G2K2-0800	75	700	7000	-20 / +100	670
G2E2-0315	5.5	1600	530	-20 / +80	48	K-0900	30	650	3000	-20 / +100	306
G2E4-0315	11	1900	660	-20 / +100	60	K1-0900	45	700	3900	-20 / +100	316
G2E7-0315	30	2100	2000	-20 / +100	73	K2-0900	75	700	7000	-20 / +100	320
E0-0355	7.5	1800	840	-20 / +80	23	G2K-0900	37	500	3000	-20 / +100	801
E2-0355	7.5	1800	840	-20 / +80	29	G2K2-0900	75	600	7000	-20 / +100	806
E4-0355	15	2000	940	-20 / +100	41	K-1000	37	600	3000	-20 / +100	333
E6-0355	22	2000	1450	-20 / +100	42	K1-1000	45	600	3900	-20 / +100	356
G2E0-0355	7.5	1500	840	-20 / +80	49	K2-1000	75	650	7000	-20 / +100	360
G2E2-0355	7.5	1500	840	-20 / +80	63	G2K-1000	37	450	3000	-20 / +100	894
G2E4-0355	15	1700	940	-20 / +100	84	G2K2-1000	75	500	7000	-20 / +100	899
G2E7-0355	30	1900	2000	-20 / +100	98						
E0-0400	7.5	1600	840	-20 / +80	31						
E2-0400	7.5	1600	840	-20 / +80	38						
E4-0400	15	1800	940	-20 / +100	52						
E6-0400	22	1800	1450	-20 / +100	53						
G2E0-0400	7.5	1200	840	-20 / +80	66						
G2E2-0400	7.5	1200	840	-20 / +80	82						
G2E4-0400	15	1400	940	-20 / +100	108						
G2E7-0400	37	1800	2950	-20 / +100	133						
E0-0450	11	1400	1180	-20 / +80	42						
E2-0450	11	1400	1180	-20 / +80	50						
E4-0450	15	1500	1320	-20 / +100	66						
E6-0450	30	1500	1800	-20 / +100	67						
G2E0-0450	11	1000	1180	-20 / +80	90						
G2E2-0450	11	1000	1180	-20 / +80	107						
G2E4-0450	15	1200	1320	-20 / +100	135						
G2E7-0450	37	1400	2950	-20 / +100	159						

# Description

## Operating limits AT

AT	Permissible nominal motor power kW	Permissible fan speed 1/min	Permissible bearing load N	Permissible media temperature °C	Fan weight kg	AT	Permissible nominal motor power kW	Permissible fan speed 1/min	Permissible bearing load N	Permissible media temperature °C	Fan weight kg
S-7/7	3	2600	350	-20 / +85	5	TIC-20/15	15	1300	1200	-20 / +100	71
SC-7/7	3	2600	350	-20 / +85	6	G2C-20/15	18.5	1300	1600	-20 / +100	137
G2L-7/7	3	2400	350	-20 / +85	11.7	G2CC2-20/15	45	1300	6500	-20 / +100	144
SC2-7/7	3	2600	350	-20 / +85	13.7	G3C-20/15	18.5	900	1600	-20 / +100	315
S-9/7	3	2500	350	-20 / +85	6.6	G3CC2-20/15	45	1100	6500	-20 / +100	319
SC-9/7	3	2500	350	-20 / +85	8.3	TIC-20/20	15	1300	1200	-20 / +100	78
AR-9/7	7.5	2500	620	-20 / +100	8.3	G2C-20/20	18.5	900	1600	-20 / +100	150
G2L-9/7	3	2400	350	-20 / +85	14.9	G2CC2-20/20	45	1200	6500	-20 / +100	158
SC2-9/7	3	2500	350	-20 / +85	18	G3C-20/20	18.5	700	1600	-20 / +100	355
G2C-9/7	7.5	2500	1000	-20 / +100	23.5	G3CC2-20/20	45	800	6500	-20 / +100	359
S-9/9	3	2100	350	-20 / +85	7.9	TIC-22/15	15	1300	1200	-20 / +100	73
SC-9/9	3	2100	350	-20 / +85	9.5	G2C-22/15	18.5	1300	1600	-20 / +100	141
AR-9/9	7.5	2100	620	-20 / +100	9.5	G2CC2-22/15	45	1300	6500	-20 / +100	148
G2L-9/9	3	2000	350	-20 / +85	18.1	G3C-22/15	18.5	800	1600	-20 / +100	340
SC2-9/9	3	2100	350	-20 / +85	21.8	G3CC2-22/15	45	1000	6500	-20 / +100	347
G2C-9/9	7.5	2100	1000	-20 / +100	27	TIC-22/22	15	1200	1200	-20 / +100	82.5
S-10/8	3	2500	350	-20 / +85	8.3	G2C-22/22	18.5	900	1600	-20 / +100	165
SC-10/8	3	2500	350	-20 / +85	9.8	G2CC2-22/22	45	1000	6500	-20 / +100	173
AR-10/8	7.5	2500	620	-20 / +100	9.8	G3C-22/22	18.5	600	1600	-20 / +100	425
G2L-10/8	3	2100	350	-20 / +85	18.5	G3CC2-22/22	45	800	6500	-20 / +100	438
SC2-10/8	3	2500	350	-20 / +85	21.8	TIC-25/20	15	1000	1600	-20 / +100	93
G2C-10/8	7.5	2500	1000	-20 / +100	27	G2C-25/20	18.5	700	1600	-20 / +100	195
S-10/10	4	2000	350	-20 / +85	9.3	G2CC2-25/20	45	800	6500	-20 / +100	202
SC-10/10	4	2000	350	-20 / +85	11	G3C-25/20	18.5	600	1600	-20 / +100	432
AR-10/10	7.5	2000	620	-20 / +100	11	G3CC2-25/20	45	700	6500	-20 / +100	436
G2L-10/10	3	1800	350	-20 / +85	21.1	TIC-25/25	15	900	1600	-20 / +100	105
SC2-10/10	3	1800	350	-20 / +85	23.5	G2C-25/25	18.5	700	1600	-20 / +100	202
G2C-10/10	7.5	1700	1000	-20 / +100	31	G2CC2-25/25	55	800	6500	-20 / +100	210
S-12/9	5.5	2000	620	-20 / +85	12.7	G3C-25/25	18.5	500	1600	-20 / +100	480
SC-12/9	5.5	2000	620	-20 / +85	16	G3CC2-25/25	55	600	6500	-20 / +100	484
AR-12/9	11	2000	1000	-20 / +100	16	TIC-28/20	18.5	800	1600	-20 / +100	120
G2L-12/9	5.5	1800	620	-20 / +85	28.2	G2C-28/20	18.5	600	1600	-20 / +100	210
SC2-12/9	5.5	2000	620	-20 / +85	34.8	G2CC2-28/20	55	800	7000	-20 / +100	218
G2C-12/9	11	2000	1200	-20 / +100	45.5	G3C-28/20	18.5	600	1600	-20 / +100	474
G3C-12/9	11	2000	1200	-20 / +100	70	G3CC2-28/20	55	650	7000	-20 / +100	478
S-12/12	5.5	1500	620	-20 / +85	15.2	TIC-28/28	18.5	800	1600	-20 / +100	127
SC-12/12	5.5	1500	620	-20 / +85	18.4	G2C-28/28	18.5	600	1600	-20 / +100	235
AR-12/12	11	1500	1000	-20 / +100	18.4	G2CC2-28/28	55	700	7000	-20 / +100	244
G2L-12/12	5.5	1400	620	-20 / +85	33.8	G3C-28/28	18.5	400	1600	-20 / +100	539
SC2-12/12	5.5	1500	620	-20 / +85	40.2	G3CC2-28/28	55	550	7000	-20 / +100	543
G2C-12/12	11	1400	1200	-20 / +100	51	TIC-30/20	18.5	800	1600	-20 / +100	131
G3C-12/12	11	1400	1200	-20 / +100	81	G2C-30/20	18.5	600	1600	-20 / +100	245
S-15/11	5.5	2000	620	-20 / +85	17.7	G2CC2-30/20	55	700	7000	-20 / +100	253
SC-15/11	5.5	2000	620	-20 / +85	20.9	G3C-30/20	18.5	550	1600	-20 / +100	505
AR-15/11	11	2000	1000	-20 / +100	20.9	G3CC2-30/20	55	600	7000	-20 / +100	509
G2L-15/11	5.5	1400	620	-20 / +85	39.7	TIC-30/28	18.5	800	1600	-20 / +100	138
SC2-15/11	5.5	2000	620	-20 / +85	46.1	G2C-30/28	18.5	600	1600	-20 / +100	302
G2C-15/11	11	1500	1200	-20 / +100	57.4	G2CC2-30/28	55	700	7000	-20 / +100	310
G3C-15/11	15	1500	1600	-20 / +100	90	G3C-30/28	18.5	400	1600	-20 / +100	577
S-15/15	5.5	1200	620	-20 / +85	20.6	G3CC2-30/28	55	500	7000	-20 / +100	581
SC-15/15	5.5	1200	620	-20 / +85	24.5						
AR-15/15	11	1200	1000	-20 / +100	24.5						
G2L-15/15	5.5	1100	620	-20 / +85	45.3						
SC2-15/15	5.5	1200	620	-20 / +85	53.1						
G2C-15/15	11	950	1200	-20 / +100	68						
G3C-15/15	15	1000	1600	-20 / +100	108						
S-18/13	7.5	1200	620	-20 / +85	27						
SC-18/13	7.5	1200	620	-20 / +85	33						
AR-18/13	15	1200	1200	-20 / +100	33						
G2L-18/13	7.5	1100	620	-20 / +85	57.8						
SC2-18/13	7.5	1200	620	-20 / +85	69.8						
G2C-18/13	15	1200	1600	-20 / +100	91						
G3C-18/13	15	1000	1600	-20 / +100	118						
S-18/18	7.5	1100	620	-20 / +85	32.5						
SC-18/18	7.5	1100	620	-20 / +85	38.2						
AR-18/18	15	1100	1200	-20 / +100	38.2						
G2L-18/18	7.5	800	620	-20 / +85	70.5						
SC2-18/18	7.5	800	620	-20 / +85	81.9						
G2C-18/18	15	1000	1600	-20 / +100	106						
G3C-18/18	15	700	1600	-20 / +100	137						



# Description

Operating limits RDH											
RDH	Permissible nominal motor power kW	Permissible fan speed 1/min	Permissible bearing load N	Permissible media temperature °C	Fan weight kg	RDH	Permissible nominal motor power kW	Permissible fan speed 1/min	Permissible bearing load N	Permissible media temperature °C	Fan weight kg
E0-0180	2.2	6800	420	-20 / +80	5.3	R-0710	15	1300	1800	-20 / +80	165
E2-0180	2.2	6800	420	-20 / +80	7.1	K-0710	22	1500	1900	-20 / +100	220
E0-0200	3	6000	420	-20 / +80	6.6	K1-0710	37	1700	3550	-20 / +100	240
E2-0200	3	6000	420	-20 / +80	8.5	K2-0710	55	2000	5800	-20 / +100	250
E4-0200	3	6800	420	-20 / +100	11.8	G2K-0710	30	1400	3000	-20 / +100	580
E0-0225	4	5800	420	-20 / +80	7.8	G2K2-0710	75	1700	7000	-20 / +100	586
E2-0225	4	5800	420	-20 / +80	9.9	K-0800	22	1200	1900	-20 / +100	270
E4-0225	4	6000	420	-20 / +100	13.6	K1-0800	37	1400	3550	-20 / +100	297
E0-0250	4	4600	420	-20 / +80	13.3	K2-0800	55	1650	5800	-20 / +100	305
E2-0250	4	4600	420	-20 / +80	15.7	G2K-0800	30	1150	3000	-20 / +100	747
E4-0250	5.5	5400	450	-20 / +100	21	G2K2-0800	75	1400	7000	-20 / +100	753
G2E4-0250	5.5	2900	450	-20 / +100	46	K-0900	30	1100	3000	-20 / +100	343
G2E7-0250	7.5	3500	660	-20 / +100	49	K1-0900	45	1250	3900	-20 / +100	355
E0-0280	5.5	4000	530	-20 / +80	17.8	K2-0900	75	1500	7000	-20 / +100	375
E2-0280	5.5	4000	530	-20 / +80	21	G2K-0900	37	1000	3000	-20 / +100	883
E4-0280	7.5	4700	660	-20 / +100	28	G2K2-0900	75	1100	7000	-20 / +100	889
G2E4-0280	5.5	3000	660	-20 / +100	61	K-1000	37	1000	3000	-20 / +100	415
G2E7-0280	11	3400	940	-20 / +100	65	K1-1000	45	1000	3900	-20 / +100	430
E0-0315	5.5	3500	530	-20 / +80	21	K2-1000	75	1300	7000	-20 / +100	450
E2-0315	5.5	3500	530	-20 / +80	25	G2K-1000	37	800	3000	-20 / +100	1048
E4-0315	7.5	4100	660	-20 / +100	32	G2K2-1000	75	800	7000	-20 / +100	1054
E6-0315	11	4500	1050	-20 / +100	34	X1-1120	55	900	8000	-20 / +100	610
G2E4-0315	5.5	2200	660	-20 / +100	70	X2-1120	110	1170	8000	-20 / +100	890
G2E7-0315	11	3300	1320	-20 / +100	79	X1-1250	75	800	8000	-20 / +100	950
E0-0355	7.5	3300	840	-20 / +80	29	X2-1250	132	1050	10000	-20 / +100	1140
E2-0355	7.5	3300	840	-20 / +80	34	X1-1400	90	720	9000	-20 / +100	1370
E4-0355	11	3800	940	-20 / +100	46	X2-1400	160	930	12500	-20 / +100	1390
E6-0355	15	4000	1450	-20 / +100	47						
G2E4-0355	7.5	2000	940	-20 / +100	104						
G2E7-0355	11	2600	1320	-20 / +100	109						
E0-0400	7.5	2700	840	-20 / +80	36						
E2-0400	7.5	2700	840	-20 / +80	42						
E4-0400	15	3100	940	-20 / +100	57						
E6-0400	22	3500	1450	-20 / +100	58						
G2E4-0400	7.5	1600	940	-20 / +100	126						
G2E7-0400	18.5	2800	1760	-20 / +100	144						
E0-0450	11	2500	1180	-20 / +80	50						
E2-0450	11	2500	1180	-20 / +80	57						
E4-0450	15	2800	1320	-20 / +100	73						
E6-0450	30	3200	1800	-20 / +100	75						
G2E4-0450	11	1400	1320	-20 / +100	160						
G2E7-0450	18.5	2200	1760	-20 / +100	176						
E0-0500	11	2100	1180	-20 / +80	62						
E2-0500	11	2100	1180	-20 / +80	70						
E4-0500	15	2350	1320	-20 / +100	90						
E6-0500	30	2650	1800	-20 / +100	92						
E7-0500	37	2800	2200	-20 / +100	110						
G2E4-0500	11	1200	1320	-20 / +100	197						
G2E7-0500	30	2200	3000	-20 / +100	235						
E0-0560	15	1950	1450	-20 / +80	79						
E2-0560	15	1950	1450	-20 / +80	92						
E4-0560	18.5	2100	1760	-20 / +100	141						
E6-0560	30	2400	2550	-20 / +100	148						
E7-0560	37	2600	3700	-20 / +100	153						
G2E4-0560	11	1100	1760	-20 / +100	301						
G2E7-0560	30	1900	3000	-20 / +100	336						
R-0630	15	1600	1450	-20 / +80	119						
K-0630	18.5	1700	1760	-20 / +100	173						
K1-0630	30	2000	2550	-20 / +100	180						
K2-0630	45	2300	3700	-20 / +100	185						
G2K-0630	15	1000	1760	-20 / +100	370						
G2K2-0630	37	1400	3000	-20 / +100	408						

# Description

## Operating limits RZR

RZR	Permissible nominal motor power kW	Permissible fan speed 1/min	Permissible bearing load N	Permissible media temperature °C	Fan weight kg	RZR	Permissible nominal motor power kW	Permissible fan speed 1/min	Permissible bearing load N	Permissible media temperature °C	Fan weight kg
11-0200	7.5	7490	480	-20 / +80	11	11-0800	22	1300	2150	-20 / +80	250
12-0200	7.5	7490	480	-20 / +80	12	14-0800				-20 / +80	327
19-0200	7.5	7490	480	-20 / +80	13	15-0800	55	1470	4500	-20 / +80	250
11-0225	7.5	6640	500	-20 / +80	13	19-0800	55	1470	4500	-20 / +80	280
12-0225	7.5	6640	500	-20 / +80	15	18-0800	55	1700	4500	-20 / +80	289
19-0225	7.5	6640	500	-20 / +80	16	13-0800	55	1700	4500	-20 / +80	319
11-0250	7.5	5250	540	-20 / +80	15	11-0900	22	1000	2180	-20 / +80	358
12-0250	7.5	5250	540	-20 / +80	17	14-0900				-20 / +80	356
19-0250	7.5	5970	540	-20 / +80	17	15-0900	75	1430	6000	-20 / +80	358
11-0280	7.5	5235	630	-20 / +80	20	19-0900	75	1430	6000	-20 / +80	396
12-0280	7.5	5235	630	-20 / +80	23	18-0900	75	1540	6000	-20 / +80	409
19-0280	11	5300	850	-20 / +80	23	13-0900	75	1540	6000	-20 / +80	447
11-0315	7.5	4418	660	-20 / +80	24	11-1000	22	800	2200	-20 / +80	416
12-0315	7.5	4418	660	-20 / +80	27	14-1000				-20 / +80	435
14-0315				-20 / +80	35	15-1000	75	1140	6200	-20 / +80	416
19-0315	11	4730	910	-20 / +80	28	19-1000	75	1140	6200	-20 / +80	462
11-0355	7.5	3200	720	-20 / +80	33	18-1000	75	1400	6200	-20 / +80	471
12-0355	7.5	3200	720	-20 / +80	36	13-1000	75	1400	6200	-20 / +80	517
14-0355				-20 / +80	50	13-1120	132	1220	10000	-20 / +80	710
19-0355	11	4187	950	-20 / +80	39	13-1250	160	1100	15000	-20 / +80	1100
11-0400	7.5	3027	1020	-20 / +80	43	13-1400	200	1000	20000	-20 / +80	1390
12-0400	7.5	3027	1020	-20 / +80	49	13-1600	250	860	20000	-20 / +80	1870
14-0400				-20 / +80	56						
15-0400	30	3600	1970	-20 / +80	61						
19-0400	30	3600	1970	-20 / +80	66						
18-0400	30	3600	1970	-20 / +80	70						
13-0400	30	3600	1970	-20 / +80	75						
11-0450	7.5	2504	1080	-20 / +80	54						
12-0450	7.5	2504	1080	-20 / +80	60						
14-0450				-20 / +80	82						
15-0450	30	3360	2000	-20 / +80	73						
19-0450	30	3360	2000	-20 / +80	82						
18-0450	30	3360	2000	-20 / +80	83						
13-0450	30	3360	2000	-20 / +80	92						
11-0500	7.5	2050	1140	-20 / +80	65						
12-0500	7.5	2050	1140	-20 / +80	72						
14-0500				-20 / +80	98						
15-0500	30	2920	2040	-20 / +80	94						
19-0500	30	2920	2040	-20 / +80	105						
18-0500	30	2920	2040	-20 / +80	105						
13-0500	30	2920	2040	-20 / +80	116						
11-0560	15	2205	1830	-20 / +80	103						
12-0560	15	2205	1830	-20 / +80	109						
14-0560				-20 / +80	156						
15-0560	37	2400	2950	-20 / +80	125						
19-0560	37	2400	2950	-20 / +80	136						
18-0560	37	2490	2950	-20 / +80	140						
13-0560	37	2490	2950	-20 / +80	151						
11-0630	15	1838	1960	-20 / +80	124						
12-0630	15	1838	1960	-20 / +80	132						
14-0630				-20 / +80	185						
15-0630	37	1880	3000	-20 / +80	149						
19-0630	37	1880	3000	-20 / +80	162						
18-0630	37	2380	3000	-20 / +80	167						
13-0630	37	2380	3000	-20 / +80	180						
11-0710	18.5	1627	2080	-20 / +80	177						
12-0710	18.5	1627	2080	-20 / +80	194						
14-0710				-20 / +80	230						
15-0710	55	2000	4400	-20 / +80	201						
19-0710	55	2000	4400	-20 / +80	225						
18-0710	55	2120	4400	-20 / +80	230						
13-0710	55	2120	4400	-20 / +80	254						

# Description

## Performance



The curves show the total pressure rise  $p_F$  as a function of the volume flow rate  $q_V$  plotted in a double logarithmic diagram. The throttle curves (system resistance parabolas) are then represented by straight lines.

The curves are established with a reference density of  $\rho_1 = 1.2 \text{ kg/m}^3$  at the fan intake.

The pressure and impeller input power are directly proportional to density  $\rho_1$ .

Outlet velocity  $v_2$  and the dynamic pressure  $p_{d2}$  refer to the flanged cross section area at the fan discharge.

The increase in static pressure  $p_{sF}$  when a duct is fitted to the discharge (Installation B) can be calculated from the equation:

$$P_{sF} = P_F - P_{d2}$$

Where no duct is fitted (Installation A) there is no static pressure regain. The increase in pressure  $p_{sF}$  can be calculated from formula:

$$P_{sF} = P_F - f_{pd} \times P_{d2}$$

**The limits of application indicated in the fan curves (by blue dotted lines) outline the recommended functional range of the fans, where a stable operation with high efficiency can be expected.**

The efficiency marked on the straight system lines is only applicable at the maximum fan speed  $N_{max}$ ; it decreases with lower fan speed.

	ADH		RDH		RZR
	0160/-0560	0630/-1000	0180/-1000	1120/-1400	1120/-1600
$f_{pd}$	1.9	1.66	1.74	1,15	1.00
RZR 0200/-1000 see fan curves					

	AT									
	7-7	9-7	9-9	10-8	10-10	12-9	12-12	15-11	15-15	18-13
$f_{pd}$	1.96	2.16	1.95	2.08	2.24	1.83	1.94	2.10	2.17	1.98
	18-18	20-15	20-20	22-15	22-22	25-20	25-25	28-20	30-20	30-28
$f_{pd}$	1.86	2.48	2.26	2.46	2.42	2.48	2.49	2.37	2.44	2.41

### Efficiency ADH / AT / RDH

The performance curves  $P_r$  of the fan curve diagram correspond to the absorbed power of the fan impeller.

The vertical scales shown at the right side of the diagram indicate the bearing power loss  $P_b$  of the different fan executions and depending on the fan speed.

The resulting power absorbed on fan shaft is found by adding the absorbed power  $P_r$  of the fan impeller and the bearing power losses  $P_b$ . As a consequence the resulting fan efficiency is to be calculated according to the formula:

$$\eta_a = \eta_r \times \frac{P_r}{P_r + P_b}$$

### Efficiency RZR

The actual efficiency value for a fan speed lower  $N_{max}$  is calculated by multiplying the efficiency at  $N_{max}$  by the factor  $f_{\eta}$  for the appropriate speed. ( $f_{\eta}$  to be found with the scale on the right side of the page).

### Motor nominal power ADH/AT/RDH/RZR

To determine the motor rating  $P_N$ , the fan absorbed shaft power  $P_r$  must be increased by a safety factor to accommodate belt drive losses and possible fan speed differences.

$$P_N \geq P_a \times f_p$$

The factor  $f_p$  is an estimated value. As an approximate value, the figures below are suggested.

ADH / AT		RDH / RZR	
$P_a < 0.75 \text{ kW}$	$f_p = 1.30$	$P_a < 0.75 \text{ kW}$	$f_p = 1.25$
$P_a \geq 0.75 \text{ kW} \dots < 10 \text{ kW}$	$f_p = 1.20$	$P_a \geq 0.75 \text{ kW} \dots < 10 \text{ kW}$	$f_p = 1.15$
$P_a \geq 10 \text{ kW}$	$f_p = 1.15$	$P_a \geq 10 \text{ kW}$	$f_p = 1.12$

# Description

## Performance

When selecting the motor, the run up time must be checked whether being within permitted limits.

The run up time can be worked out approximately according to the following formula:

$$t_A = \frac{8 \times J \times N^2}{P_N \times 10^6}$$

where:

$t_A$  = run time in seconds

$J$  = moment of inertia in kgm<sup>2</sup>

$N$  = fan speed in rpm

$P_N$  = motor rating in kW

(Impeller weight and moment of inertia can be found on the performance diagram for each fan size.)

If  $t_A$  exceeds the motor manufacturer's recommendation or the tripping period of the electrical gear, a larger motor must be used or the starting gear has to be selected for heavy starting.

- 1 = Test fan
- 2 = Discharge duct
- 3 = Screen
- 4 = Multiple nozzles
- 5 = Auxiliary fan and damper

Fan curves measurement ADH/AT/ RDH - AMCA 210-99 / ISO 5801

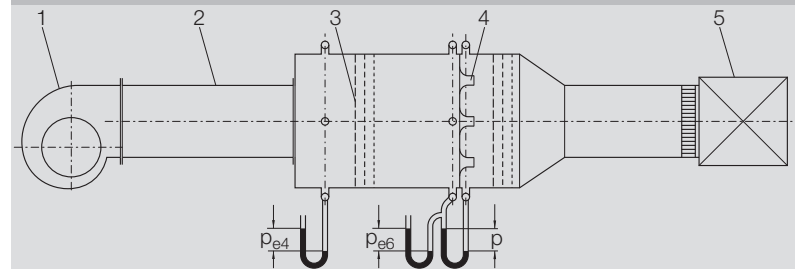

- 1 = Test fan
- 2 = Discharge duct acting as a pressure regain unit
- 3 = Screen
- 4 = Variable damper
- 5 = Compensating fan
- 6 = Flow straightener
- 7 = Inlet cone

Fan curves measurement RZR - ISO 5801 / DIN 24163

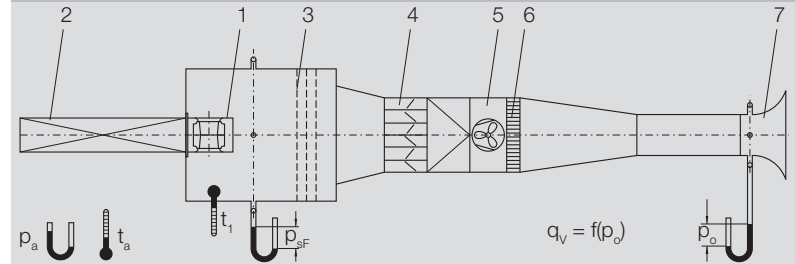

### Performance data of twin fan units

The performance data of twin fan units (Identification "G2") can be calculated, starting from that in the corresponding operating point of a single fan, with the following formulas:

**Fan Pressure:**  $p_{F\ G2} = p_F \times 1$

**Volume flow rate:**  $q_{V\ G2} = q_V \times 2$

**Fan shaft power:**  $P_{a\ G2} = P_a \times 2,15$

**Rotational speed:**  $N_{G2} = N \times 1,05$

**Sound:**  $L_{WA\ G2} = L_{WA} + 3\text{ dB}$

# Description

## Sound



Noise measurements are undertaken in accordance with DIN 45635-38 "Noise Measurement of Machines: Fans".

### Induct Method for the Discharge

The induct method is specified with DIN EN ISO 5136. It determines the sound power emitted at discharge of a test fan.

The test duct, as a main feature, is equipped with an anechoic termination fitted to avoid end reflection going back into the duct.

### Envelope Method – Free Inlet

The Envelope Method is described with DIN 45 635-1 and -38, which specifies a hypothetical box shaped measurement surface with several prescribed measurement points.

- 1 = Air permeable sound screen
- 2 = Microphone positions for envelope method
- 3 = Test fan
- 4 = Measuring duct
- 5 = Microphone with sampling tube
- 6 = Anechoic termination
- 7 = Step less adjustable throttle

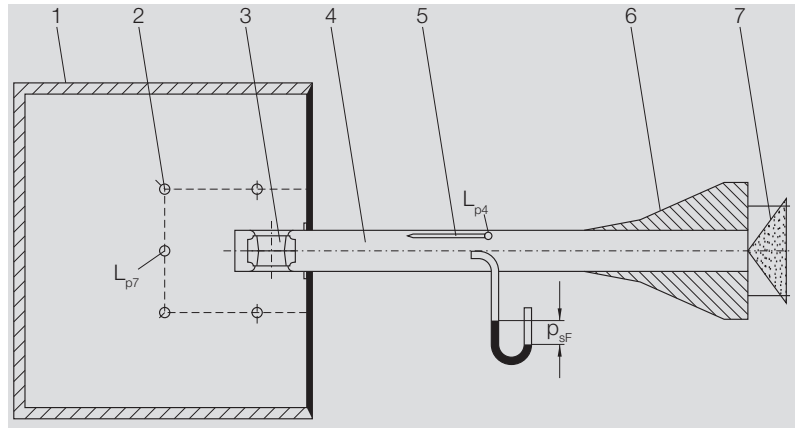

The sound data of the fan curves are given as "A" weighted sound power levels.

### A-sound power level RZR rotavent

The "A" weighted sound power level are identical for fan intake ( $L_{WA7}$ ) as well as for fan discharge ( $L_{WA4}$ ).

### A-sound power level ADH / AT / RDH

The "A" weighted sound power level (see curves) are apply for fan intake ( $L_{WA7}$ ). The fan discharge sound power level  $L_{WA4}$  is obtained by calculating:

$$L_{WA4} = L_{WA7} + \Delta L_{Wrel4}(A)$$

The correction value  $\Delta L_{Wrel4}(A)$  is found with the table (left below) at the corresponding fan curve page (ADH/RDH) by introducing fan speed and flow rate.

# Description

## Sound

An approximation of the “A” weighted sound pressure levels  $L_{pA7}/L_{pA6}$  at a distance of 1 m may be obtained by subtracting 7 dB from the relative “A” weighted sound power levels.

It should be noted that site acoustics, duct design, reverberation, natural frequencies etc. can all influence noise to a greater or lesser extent.

For more accurate calculations to determine noise protection measures, the sound power level in each octave band is of more value:

### RZR

$$L_{Wfc7} = L_{WA4;7} + L_{Wrel7}$$

$$L_{Wfc4} = L_{WA4;7} + L_{Wrel4}$$

### ADH / AT / RDH

$$L_{Wfc7} = L_{WA7} + L_{Wrel7}$$

$$L_{Wfc4} = L_{WA7} + L_{Wrel4}$$

The noise correction data  $L_{Wrel4}$  and  $L_{Wrel7}$ , in function of the fan speed and flow rate, are to be found with the corresponding table on the fan curve page.

In some cases the noise level - calculated by this way - may in some cases be higher than expected at the blade passing frequency.

$$f_{BP} = \frac{N \times z}{60}$$

$f_s$  = Blade passing frequency in Hz

N = Fan speed in 1/min

z = No of blades (see curve pages)

For a free discharge situation i.e. without duct connected the sound level will be lower because of an end reflection.

This is specially true for low frequencies. For this case a correction may be applied to  $L_{Wfc4}$  of the first 3 octave bands as follows:

$$L_{Wfc6} = L_{Wfc4} + L_{Wer}$$

ADH / AT / RDH / RZR	$f_m$	63	125	250	Hz
0160/-0280	$L_{Wer}$	-14	-9	-4	dB
0315/-0800	$L_{Wer}$	-9	-4	-2	dB
0900/-1600	$L_{Wer}$	-4	-1	0	dB

# Description

## Explosion protection according to ATEX



Fans for use in explosive atmospheres must comply with EC Directive 94/9/EG (ATEX 95). Equipment in Group II (all applications except mining) is categorised in accordance with the required degree of safety for designated use in equipment categories 1, 2 and 3. Depending on suitability, a distinction is in addition made between G (gas, vapours) and D (dust).

Harmonised European standards and national guidelines must be observed. Equipment in class 2 and 3 is not subject to compulsory specifications nor to type testing. The manufacturer declares conformity with the EC directive.

### For the standard designs of our fans, the following ignition sources are essentially to be considered:

- Hot surfaces, e.g. due to heat of friction or seizure of a bearing or due to blockage of an impeller
- Rubbing-, grinding- or beating sparks, e. g. as a result of contact of the impeller with stationary components
- Sparks resulting from discharge of electrostatically loaded, non-conducting components, e. g. of plasticpanels, surfaces with strong layer thickness.

### Preconditions for operating:

- **In the proximity of the motor, the temperature limits -20°C and +40°C must not be exceeded.**
- **The temperature limits of -20°C und +60°C for the flow medium must not be exceeded. If the temperature of the flow medium should exceed +60°C on the pressure side, then the fan must be switched off!**
- **The fans may only be employed with a horizontal shaft.**
- **The fans are to be protected against the falling-in or sucking-in of foreign objects. Protection guards must be ordered separately as an accessories.**
- **On the machine plate the max. permitted fan speed is indicated.**
- **Fans for operation in ex-hazardous areas are marked as such on the machine plate and they are accompanied by an EU conformity declaration and with operation and maintenance instructions.**

*The operation and maintenance instructions have strictly to be observed.*

The conformity is always related to the fan system supplied.

If the fan is completed with motor and belt drive by the customer the conformity of this fan set has to be declared at new.

**Fans of the series ADH / AT / RDH in ATEX-Execution on request.**

# Description

## Operating limits RZR ATEX

RZR	Permissible fan speed 1/min	Permissible shaft power kW	Permissible nominal motor power kW
11-0200-2G	6513	4.7	5.5
12-0200-2G	6513	4.7	5.5
19-0200-2G	6513	4.7	5.5
11-0225-2G	5774	4.7	5.5
12-0225-2G	5774	4.7	5.5
19-0225-2G	5774	4.7	5.5
11-0250-2G	4620	4.7	5.5
12-0250-2G	4620	4.7	5.5
19-0250-2G	5076	4.7	5.5
11-0280-2G	4582	6.5	7.5
12-0280-2G	4582	6.5	7.5
19-0280-2G	4582	9.7	11
11-0315-2G	3793	6.5	7.5
12-0315-2G	3793	6.5	7.5
19-0315-2G	4113	9.7	11
11-0355-2G	3110	6.5	7.5
12-0355-2G	3110	6.5	7.5
19-0355-2G	3555	9.7	11
11-0400-2G	2552	6.5	7.5
12-0400-2G	2552	6.5	7.5
13-0400-2G	3145	16.4	18.5
18-0400-2G	2913	9.7	11
11-0450-2G	2111	6.5	7.5
12-0450-2G	2111	6.5	7.5
13-0450-2G	2922	21.3	24
18-0450-2G	2410	9.7	11
11-0500-2G	1752	6.5	7.5
12-0500-2G	1752	6.5	7.5
13-0500-2G	2534	21.3	24
18-0500-2G	2000	9.7	11
11-0560-2G	1660	9.7	11
12-0560-2G	1660	9.7	11
13-0560-2G	2163	26.6	30
18-0560-2G	1660	9.7	11
11-0630-2G	1367	9.7	11
12-0630-2G	1367	9.7	11
13-0630-2G	2055	32.8	37
18-0630-2G	1367	9.7	11
11-0710-2G	1128	9.7	11
12-0710-2G	1128	9.7	11
13-0710-2G	1825	40.9	45
18-0710-2G	1128	9.7	11
11-0800-2G	927	9.7	11
18-0800-2G	927	9.7	11
13-0800-2G	1474	40.9	45
11-0900-2G	767	9.7	11
18-0900-2G	767	9.7	11
13-0900-2G	1339	68	75
11-0100-2G	650	9.7	11
18-1000-2G	650	9.7	11
13-1000-2G	1217	68	75
13-1120-2G	1026	83.6	92
13-1250-2G	957	122	135
13-1400-2G	870	145	160
13-1600-2G	748	181	200



# Notes

## Quality management system

### DIN EN ISO 9001

Nicotra Gebhardt quality is the result of a continuous company policy intended to guarantee that our product properties and features are clearly superior to comparable products.

This already established company maxim led in April 1985 to the auditing and certification of the existing quality management system. In the following years it was updated to match the changing international and European standards. Modern production processes, monitored by our quality management system, guarantee a high repeat accuracy in production.

This ongoing high standard of quality permits the establishing of the performance data in classes of accuracy in accordance with DIN 24166.

The narrow tolerances ensure a high level of data reliability for our products.

## Machine Safety

The fans contained in this catalogue are not machines in the sense of the EC Machine Directive. They are delivered with a manufacturer "Declaration of incorporation".

The assessment of the dangers associated with the fan and necessary safety measures are based on the VDMA Unit sheet 24167 : Fans; Safety requirements.

The operating instructions give which safety measures are still necessary on assembly to ensure that the fans comply with the Machine Directive 2006/42/EC.

## Catalogue data

We reserve the right to change any measurements and technical data in this catalogue in accordance with further development of our products. All information valid at the time of printing.

# Nicotra Gebhardt worldwide

## SPAIN

Ctra. Alcalá-Villar del Olmo, Km. 2,830  
28810 Villalbilla-Madrid  
Phone +34 918-846110  
Fax +34 918-859450  
E-mail info@nicotra.es

c/.Coso, 67-75, esc. 1.a,1.oB  
50001 Zaragoza  
Phone +34 976-290550  
Fax +34 976-298127  
E-mail gebhardt@teleline.es

## BELGIUM

Haeghensgoed, 13 - 00/01  
9270 Laarne  
Phone +32 (0)9-336-00-01  
Fax +32 (0)9-336-00-05  
E-mail info.nicotra@nicotra.be

## FRANCE

Leader's Park Bat A1  
3 chemin des Cytises  
69340 Francheville  
Phone +33 (0)4 72 79 01 20  
Fax +33 (0)4 72 79 01 21  
E-mail g.cauche@nicotra-gebhardt.com

## SWEDEN

Box 237  
Kraketorpsgratan 30  
43123 Mölndal  
Phone 0046 31-874540  
Fax 0046 31-878590  
E-mail info@nicotra-gebhardt.se  
<http://www.nicotra-gebhardt.se/>

## GREAT BRITAIN

Unit D, Rail Mill Way  
Parkgate Business Park  
Rotherham  
South Yorkshire  
S62 6JQ  
Phone +044 01709-780760  
Fax +044 01709-780762  
E-mail sales@nicotra.co.uk

## UNITED STATES

PO BOX 900921  
Sandy, Utah 84090  
Phone 001(801) 733-0248  
Fax 001(801) 315-9400  
Mobile 001(801) 682 0898  
E-mail mike.sehgal@gebhardtfans.com  
<http://www.gebhardtfans.com/>



## MALAYSIA

Lot 1799, Jalan Balakong  
Taman Perindustrian Bukit Belimbing  
43300 Seri Kembangan  
Selangor  
Phone +603 8961-2588  
Fax +603 8961-8337  
E-mail info\_malaysia@nicotra-gebhardt.com

## THAILAND

6/29 Soi Suksawadi 2, Moo 4, Suksawadi Road,  
Kwang Jomthong, Khet Jomthong,  
Bangkok 10150  
Phone +662 476-1823-6  
Fax +662 476-1827  
E-mail sales@nicotra.co.th

## SINGAPORE

No. 15 West Coast Highway  
# 04-08 Pasir Panjang Building  
Singapore 117861  
Phone (065) 6265-1522  
Fax (065) 6265-2400  
E-mail info@gebhardt-singapore.com

## AUSTRALIA

47 Jessica Road,  
Campbellfield, VIC 3061  
Phone +613 9357-7464  
Fax +613 9357-8700  
E-mail info@nicotra.com.au

## INDIA

28F & 29, Sector 31  
Kasna, Greater Noida  
U.P. INDIA  
Phone +91 0120-4203400  
Fax +91 0120-4203401  
E-mail sales@nicotraindia.com

## CHINA

88 Tai'An Road, XinQiao, ShiJi, Panyu  
Guangzhou 511450  
PR CHINA  
Phone +86 (0)20-39960570  
Fax +86 (0)20-39960569  
E-mail sales@nicotra-china.com

# NICOTRA | Gebhardt

## Nicotra Gebhardt S.p.A

Via Modena, 18  
24040 Ciserano Loc. Zingonia (BG)  
Italy

Phone +39 035 873 111  
Fax +39 035 884 319  
E-mail info@nicotra-gebhardt.com

[www.nicotra-gebhardt.com](http://www.nicotra-gebhardt.com)

## Nicotra Gebhardt GmbH

Gebhardtstrasse 19-25  
74638 Waldenburg  
Germany

Phone +49 (0)7942 101 0  
Fax +49 (0)7942 101 170  
E-mail info@nicotra-gebhardt.com

[www.nicotra-gebhardt.com](http://www.nicotra-gebhardt.com)

fan|tastic solutions