

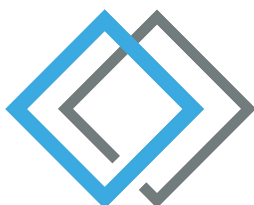

LIBERTY COMPOSITE AIR HANDLING UNITS

Installation & maintenance instructions

I&M LIBERTY INSTRUCTIONS VERSION 8.2 EN | KC
APRIL 2026 | WWW.ROSENBERG.NL/EN



LIBERTY
Composite Air Handling Units
by rosenberg nL

Table of contents

1.	Important information	5	9.	Inspection and maintenance	30
2.	Safety regulations	6	9.1	General	30
3.	Technical description	8	9.2	Casing	30
4.	Storage and transport	9		9.2.1 Outdoor installation	30
4.1.	Interim storage	9		9.2.2 Inspection panels and locks	30
4.2.	Transport by forklift truck	9	9.3	Intake and exhaust grids with droplet eliminator	31
4.3.	Transport by crane	9	9.4	Dampers	31
5.	Installation of roof curb and air handling unit	11	9.5	Air filters	31
5.1.	Installation	11		9.5.1. Bag filters	32
5.2.	Anti-vibration pads	11		9.5.2. Compact filters	32
	5.2.1. Installation outdoors	12	9.6	Cross-flow / counter-flow plate heat exchanger	32
5.3.	Installation of roof curb	13	9.7	Rotary heat exchanger	34
6.	Assembly of sections	14	9.8	Run-around-coil systems	35
7.	Connections	17	9.9	Water coils	35
7.1.	General	17	9.10	DX coil	36
7.2.	Air duct connections	17	9.11	Electric heater	36
7.3.	Connecting water coils	17	9.12	Siphons and water drains	36
7.4.	DX coils	18	9.13	Fans	36
7.5.	Run-around-coil systems	18		9.13.1 Direct-driven fans	36
7.6.	Siphons and water drain lines	19		9.13.2 Indirect-driven fans	37
	7.6.1. Positive pressure siphon	19	9.14	Humidifiers	38
	7.6.2. Negative pressure siphon	20	9.15	Noise attenuators	38
7.7.	Electric heaters	21	9.16	Controls	38
7.8.	Humidifiers	22			
7.9.	Electrical connections	22			
	7.9.1 Fan with standard motor	22			
	7.9.2 Fan with EC motor	23			
	7.9.3 Frequency inverters	23			
	7.9.4 Rotary heat exchanger	24			
	7.9.5 Maintenance switches	24			
	7.9.6 Actuators	24			
	7.9.7 Integrated control	24			
8.	Start-up	24			
8.1.	General	24			
8.2.	Damper registers	24			
8.3.	Filters	24			
8.4.	Cross-flow plate heat exchanger/ counter flow plate heat exchanger	25			
8.5.	Rotary heat exchanger	25			
8.6.	Run-around-coil systems	26			
8.7.	Water coils	26			
8.8.	Electric heater	26			
8.9.	Siphons and water drain lines	27			
8.10.	Fans	27			
	8.10.1 Direct-driven fans	27			
	8.10.2 Indirect-driven fans	28			
8.11.	Humidifiers	28			
8.12.	Test runs	28			
8.13.	Integrated control	29			

1

Important information



These installation and maintenance instructions serve as a manual for transporting, installing, starting up and maintaining Liberty Composite AHU plastic air handling units.

The manual is intended for technical installation, electrical and maintenance personnel and shall always be kept close to where the air handling unit is installed and read by everyone whose task it is to work on the product!

Liberty Composite AHU accepts no liability for injury to people or damage to material as a result of non-compliance with this manual.

The air handling unit and all corresponding components must be used correctly and according to these instructions. If installation is not carried out according to these conditions and the cause of any defects and/or damage that may have occurred can be traced to an incompetent change, processing or other treatment, any claims to damage compensation or granting warranty will be excluded. In those cases, the user must be able to demonstrate that the incompetent action(s) was/were not the cause of the defect that occurred.

Liberty Composite AHU accepts no responsibility for consequential damages. The transport, installation, start-up and maintenance instructions as described in this general manual must always be complied with for Liberty Composite AHU air handling units.

Transport, installation, start-up and maintenance may only be carried out by personnel trained and qualified for this purpose.

2

Safety regulations

Liberty air handling units comply with the relevant safety and health regulations in the EC Machinery Directive. Nevertheless, a hazard may occur if the air handling unit is not transported, installed, operated and maintained by personnel trained for this purpose, or if it is not used for the intended purpose according to the regulations.

Non-compliance with these installation and maintenance instructions can pose a hazard for those whose task it is to work on the unit or can result in breakdowns or cause damage.

The air handling unit is part of an installation for ventilating and/or conditioning a building or part of a building. The air handling unit cannot be started up safely until it has been integrated (after connecting air ducts, electrical power supply and pipe system).



All equipment should be disconnected from the power supply before work is undertaken on the air handling unit, and it should be verified whether the following conditions have been met.

- All maintenance switches installed on the air handling unit are switched off and locked in the off position. A maintenance switch on the fan included in the delivery is only intended to switch the fan off when working on the unit and to prevent the fan from being switched on unexpectedly.
- Rotating parts have come to a standstill by observing sufficient waiting time after switching the unit off.
- Components have cooled down to ambient temperature.



When using a frequency converter (FC), the safety instructions as presented in the operating manual must be observed. Furthermore, the recommendations to prevent electromagnetic failures must be complied with for all electric components.



Only qualified personnel designated for this purpose may transport, install, operate and maintain the air handling unit.

Personal protective equipment shall be used during transport, installation and maintenance work in order to prevent the risk of injury.

The inspection hatches of sections where components are installed that may pose a hazard to people (fans, electric heaters, steam humidifiers) must be locked with the keys included in the delivery during operation so that unauthorised persons have no access to these sections. Locking the inspection hatches for the remaining sections is recommended as well.

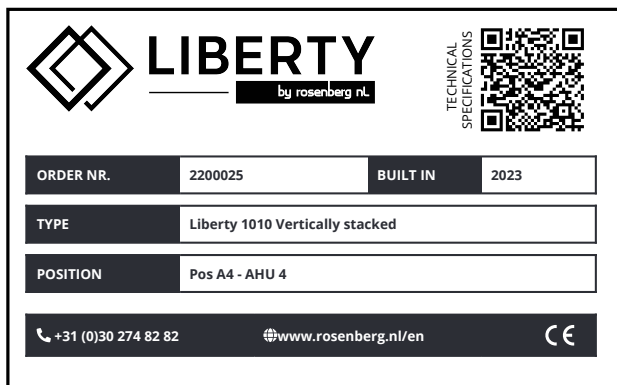

Figure 1 Name plate with QR code

The air handling unit is suitable for air supply, air exhaust and conditioning of atmospheric air, free of aggressive gases and vapours, under operating conditions as indicated in the technical specifications. The air handling unit must be mounted in a place for which the unit was designed.

The technical specifications can be consulted online at any time by scanning the QR code on the type plate of the relevant air handling unit. Exposure of the air handling unit to extreme temperatures, high pressures or abnormal external impacts can result in hazardous situations and/or damage to the product!



The following must be verified before first start-up and after inspection, cleaning or maintenance work:

- there is no longer anyone present in the air handling unit or connecting ducts
- all safety provisions have been re-installed
- any loose objects have been removed from the air handling unit

3

Technical description



The Liberty air handling unit consists of a fibre glass-reinforced composite casing construction with a support frame made of the same material. The functionality of the air handling unit is determined by the built-in components.

A rough distinction is made between a single air handling unit, which only allows air to flow in one direction, and a double air handling unit, designed for two air flows.

The air handling units are used for ventilation and/or conditioning of office and school buildings, swimming pools, hospitals and nursing homes, factories, warehouses, etc.

Liberty air handling units can be supplied with the following components, depending on the functionalities the unit should perform:

- plastic intake and exhaust grid
- droplet eliminator behind the intake and exhaust grid
- dampers in various designs
- air filters in various designs
- heat recovery (plate exchangers, rotary heat exchangers, run around coils)
- heaters and coolers in various designs (water, electrical, DX)
- water and steam humidifiers
- fans (EC fans, V-belt driven fans, direct driven fans)
- noise-attenuating splitters

The air handling unit can be further equipped with various accessories, such as:

- inspection glasses
- pressure difference manometers and pressure switches
- temperature and pressure sensors
- actuators
- lighting
- cabling
- complete control

The technical specifications of the air handling unit state the functions and accessories of the relevant unit (see also 2).

The electrical, hydraulic and technical air connections must correspond with the data in the technical specifications. The air handling unit must not be exposed to operating conditions more severe than indicated in the specifications.

Inadmissible application areas include

- extreme medium- and ambient temperatures above or below the design values
- higher or lower static pressures than to be expected based on the fan selection
- extraction or intake of air with high concentrations of aggressive vapours or abrasive substances

Inadmissible operating conditions include

- higher fan speeds than indicated in the technical specifications
- fan speeds (in the case of the speed control) that coincide with resonance frequencies
- operation points beyond the boundaries of the fan's admissible selection area
- operation of a unit with severely fouled components
- frequent switching on and off of the fan

4

Storage and transport



Upon delivery the air handling unit must be checked for transport damage and completeness. Damage and missing components shall immediately be reported to Liberty Composite AHU and noted on the accompanying transport bill.

4.1. Interim storage

If the air handling unit is stored somewhere for interim storage, it shall always rest on a flat surface. Pallets and packaging materials may not be removed in this case. The storage area shall be dry. Air handling units or sections thereof may never be stacked on top of each other.

4.2. Transport by forklift truck

If an air handling unit is on a pallet, it can be moved with a forklift truck provided the pallet forks used are long enough. We recommend inserting the forklift truck forks all the way through the pallet.

If the air handling unit is equipped with a base frame, it can be lifted and transported with a forklift truck. The air handling unit may only be lifted via the base frame. When the air handling unit is transported by forklift truck, both its lateral foundation profiles must rest on the forks.

4.3. Transport by crane

Air handling units that are too large or too heavy to safely transport by pallet usually have a hoisting device. Two or more hoisting beams are incorporated in the base frame of the unit. The hoisting beam is fitted with two locking pins at the ends so the hoisting straps cannot slide off during hoisting. The hoisting beams are calculated and tested to 150% of the load and are suitable for single use.

Larger air handling units have more than four hoisting points. These additional hoisting points should be used (more than 4 hoisting points for extremely long or heavy units).

The protruding rain edges of all air handling units suitable for outdoor installation, must be protected during crane transport with a guide frame or spacers (not included in the delivery). The angle between two hoisting points may not be greater than 60° during hoisting.

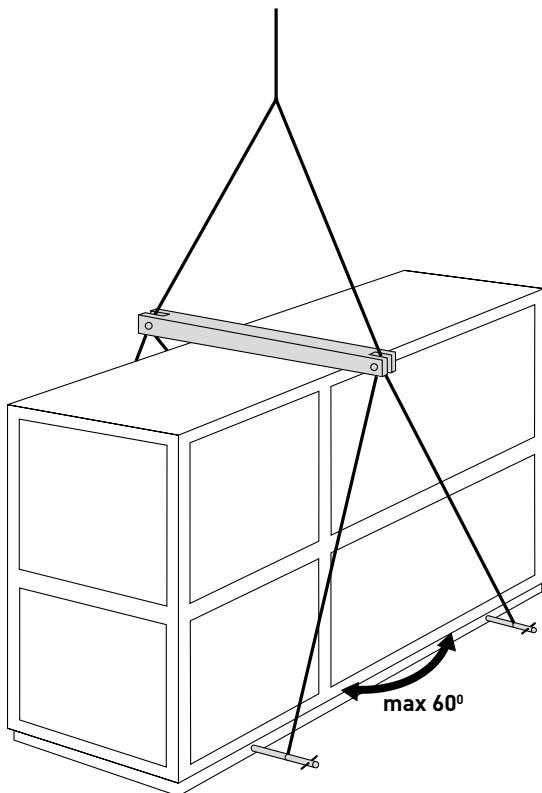

Figure 2 Hoisting instructions

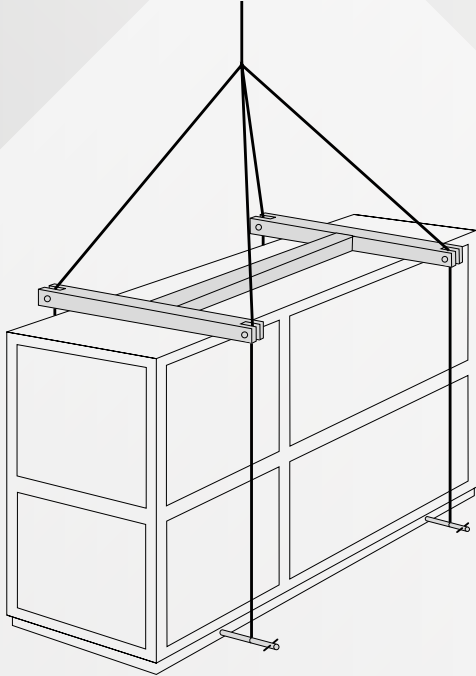

Figure 3 Use a spacer bar between the two spreader beams

If an air handling unit cannot be hoisted using the hoisting beams included in the delivery, it can be hoisted with the receiver's hoisting devices as long as they meet the current requirements. The hoisting equipment and method must not cause any damage to the air handling unit.

Take into account that the centre of gravity is not in the middle of the air handling unit due to the position of components in the casing.

If an air handling unit is not equipped with hoisting facilities, it can be hoisted using a pallet or any other method at the discretion of a person or company authorised for this with a sound hoisting plan.



Pay attention to protruding parts such as actuators and drain lines. The inspection panels must always be closed during transport.

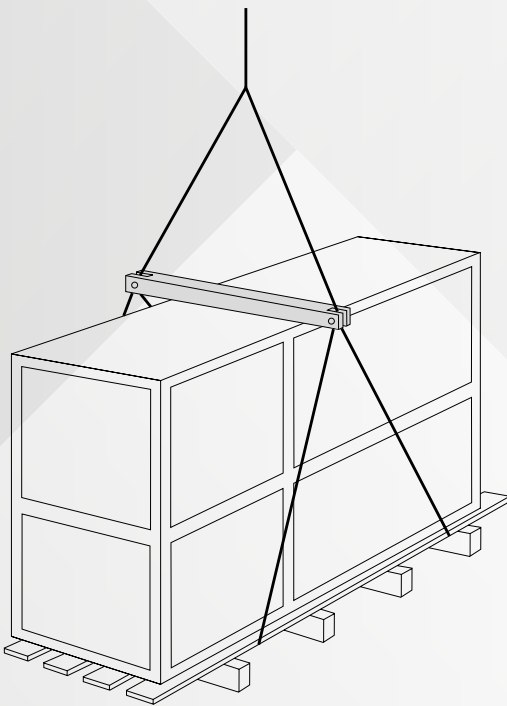

Figure 4 Hoisting instructions with use of a pallet

5

Installation

5.1. Installation



The Liberty-type air handling unit shall be mounted on a completely flat and horizontal surface.

The unit can only function optimally when placed on a surface that is level in every direction as otherwise condensate may accumulate and leakages may occur. The base frame of the air handling unit shall be supported by a support point at least every metre. If air handling units have a middle beam in the base frame, it must be supported as well.

The size of a support point is 100 x 100 mm minimum.

Protect the air handling unit from damage and never step on the top of the unit without protecting it from damages.

After installation carefully cover the air handling unit until start-up to prevent damage and contamination.

The height of the installation structure of air handling units with condensation drain line must be at least equal to or higher than the siphon height required (see the chapter entitled Siphon).

A space of at least the width of the air handling unit must be kept free on the inspection side(s) for operation and maintenance of the unit, or in the case of double units, a space of at least the width of the intake and exhaust component, respectively.

5.2. Anti-vibration pads

Anti-vibration pads can only be used underneath the support frame if the air handling unit is accessible from all sides at the installation location to place the pads at the correct support points. The intended deflection can only be realised if this is the case. It is also important to have sufficient support points under the base frame in order to prevent excessive material tension and/or excessive deflection.

In practice, it is difficult to position anti-vibration pads under the middle beams of the support frame as they cannot be installed during placement of the air handling unit. This can only be done in advance by gluing the pads on the surface on exactly the right spots. Shifting the air handling unit during positioning creates the risk of the anti-vibration pads coming loose from the surface and the middle beams will still not be supported at the right points.

5

Installation

The effectiveness of anti-vibration pads as vibration isolator is often overestimated. When using a single layer per support point, the maximum feasible deflection for commonly applied anti-vibration pads is 1.5 to 2.0 mm. In that case the resonance frequency is between 12.9 and 11.15 Hz (775 and 670 rpm). In practical terms, there will not be any vibration isolation until the excitation frequency is above 16 to 18 Hz (960 to 1080 rpm).

In all cases there is no point in placing anti-vibration pads under air handling units for outdoor installation, as the support frame must be mechanically connected to the structure of the building. This always creates a rigid connection between the air handling unit and the structure, which means that any vibration cannot be isolated. Moreover, the anti-vibration pads would be damaged by overload when tightening the attachment points.

In summary, the use of anti-vibration pads is generally not recommended, because:

- in many cases it is practically impossible to put the pads in the right positions
- actual deflection is usually much less than the optimum value as the reaction forces on the support points are unknown and/or the dimensions of the pads are not adjusted to the loads
- the effect of the vibration isolation is fairly limited due to the low level of deflection, even under optimal conditions.

We recommend only using anti-vibration pads for lightweight structures where structure-borne noise between the base frame of the air handling unit and the support structure must be prevented.

We also advise against using anti-vibration pads to compensate for any unevenness in the surface underneath the unit since this can cause uneven loads on the support frame (insufficient and/or uneven support points).

5.2.1. Installation outdoors

When setting up a unit outdoors, the base frame along with the air handling unit should not serve as a replacement for the roof in that situation!



Air handling units suitable for outdoor installation always need to be mechanically connected to the structure of the building! Do not step onto the unit without taking precautionary measures and beware of risks of slipping!

5.3. Installation of roof curb

Instructions for use/principle detail of the roof curb

In consultation, Liberty Composite AHU and Vebidak, the Vereniging Dakbedekkingsbranche Nederland [Dutch Roofing Sector Association] have developed a principle detail for waterproof construction/integration of the Liberty Composite AHU roof curb with air handling unit on the roof. The Liberty Composite AHU roof curb must be integrated in accordance with the basic principle of the Professional Directive of Vebidak, standard detail OS 08M with a few additions.

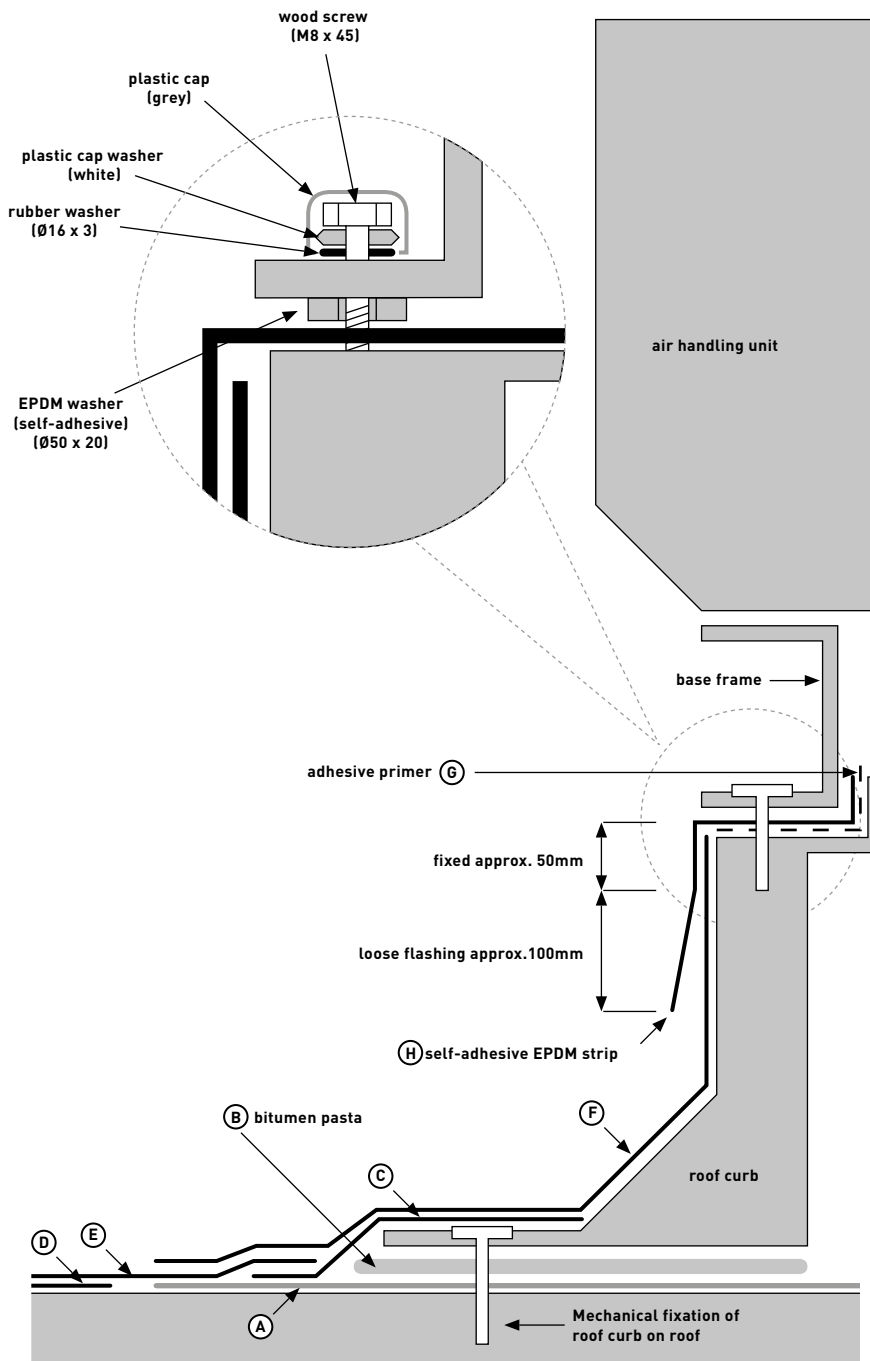

Interpretation of Code OS 08 M:

- (A) Apply a roofing felt strip under the roof curb flashing up to approx. 250 mm next to the roof curb flashing or apply the first layer (D) up to the reveal.
- (B) Mount the roof curb in a layer of bitumen pasta and fasten it to the roof construction. Smear a bitumen solvent on to the adhesive surfaces of the roof curb.
- (C) Affix a strip of roofing felt from the slant of the roof curb, extending up to 150 mm on the roof surface next to the roof curb flashing.
- (D) Mount the first layer of roofing felt, adjoining strip A underneath the curb base plate.
- (E) Install the top ply of the roof covering up to the roof curb.
- (F) Apply a roofing felt strip from the top of the roof curb to the roof surface, up to at least 70 mm alongside the perimeter of the roof curb flashing.

Supplement to OS 08 M in consultation with Vebidak:

- (G) Smear a layer of adhesive primer over the entire surface where the EPDM strip is bonded. Use the adhesive primer in accordance with the supplier's specification; e.g. FG35.
- (H) Affix and stick a continuous strip of self-adhesive reinforced EPDM, 1.6 mm thick (for example, Resistit ESK) on the horizontal surface of the roof curb. The uppermost 50 mm of the vertical section of the roof curb; leave approx. 100 mm free for future maintenance. Apply the EPDM foil to the rear up to the top of the roof curb gutter upstand. In the corners of the roof curb the EPDM strip shall be fixed butt-jointed (where the base frame of the air handling unit is supported).
- (I) Fasten the base frame with wood screws, provided with sealing washers, according to detailed sketch. [supplied by Liberty Composite AHU]

Figure 5 Principle detail of the roof curb

6

Assembly of sections

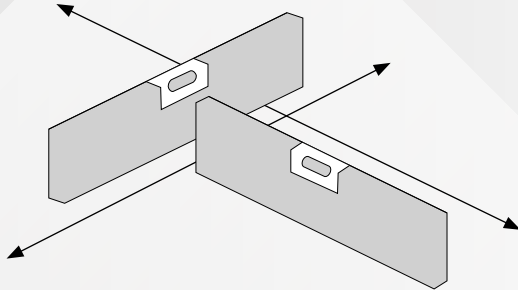

Figure 6 Installation location check

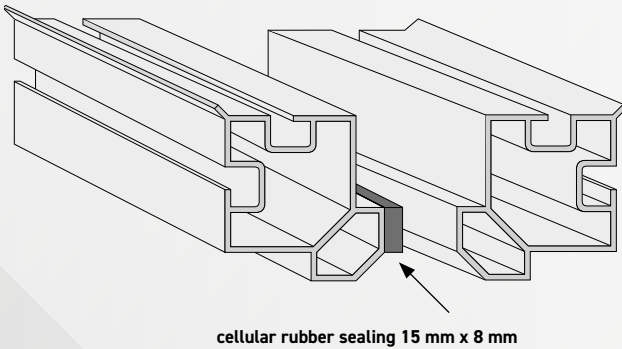

Figure 7 Cellular rubber sealing

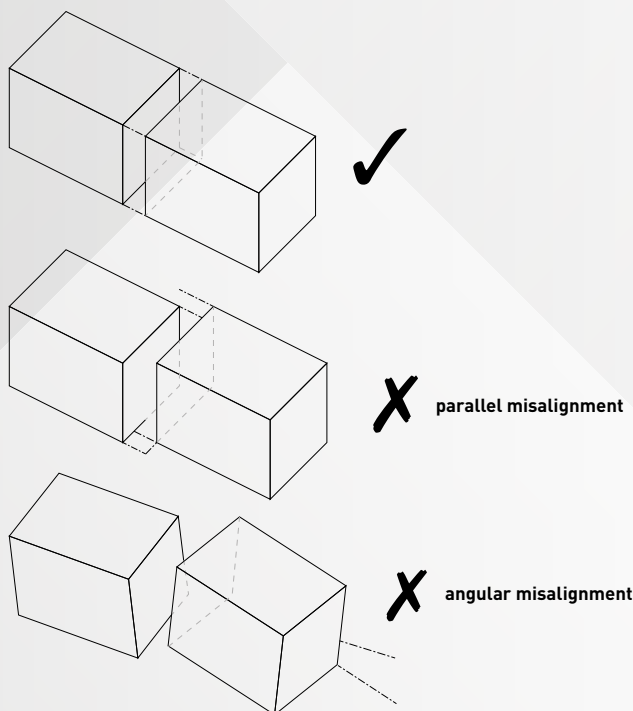

Figure 8 Aligning sections

Before starting to install parts of the air handling unit, it is important to ensure that the surface underneath the unit is absolutely flat. Since an air handling unit installed in sections does not have a one-piece base frame, the assembled unit is not rigid enough to overcome unevenness of the support floor. The surface underneath the unit must also be completely horizontal (this applies to any air handling unit), otherwise (among others), problems with condensate drainage may occur.

A To join the sections, the simplest way is to first move the heaviest/largest part of the unit to its final position. This is because the lighter unit sections will move towards the heaviest one when they are joined. If this work sequence is not possible, the lighter unit component must first be anchored to the surface underneath the unit. Once all the sections have been assembled into one air handling unit, we recommend not to move the unit anymore since that would put a high load on the joints that could result in irreparable damage to the air handling unit.

Before the units are moved next to each other, sealing tape must first be affixed to one of the sections (black cellular rubber 15 mm x 8 mm) as indicated.

B Slide the sections of the air handling unit as close possible to one another to join the sections. Alignment in the length-axis of the air handling unit is especially important because otherwise the fixing holes will not match. Moreover, the forces will be distributed poorly when the connection bolts are tightened.

It is important to ensure that the centre lines of the sections line up with one another. Parallel displacement and/or angular rotation should be avoided as far as possible. Alignment can be checked with a thin cord that is held along the vertical and horizontal surfaces in turn. The cord must be in (virtually) complete contact with the surfaces!

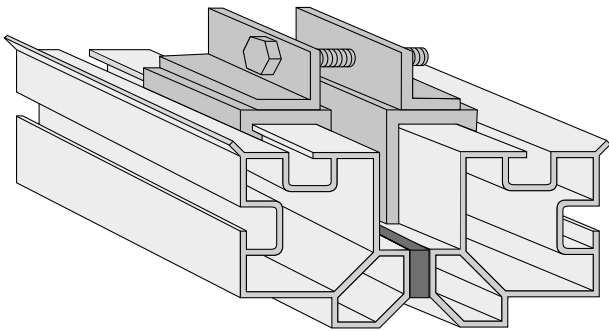

Figure 9 Accessory for joining sections of the unit

C Aluminium coupling accessories are included to pull the parts together and to press the sealing tape onto them. Distribute the included accessories evenly around the perimeter of the seam and position the accessories so that the connecting strips can be inserted at the correct distance between them (see table)! Pull the parts together by tightening the bolts (M8 × 80) that are included in a crosswise pattern.

It is very important that this is done evenly because otherwise the forces on a coupling piece can become too high, which can damage the coupling piece or the air handling unit.

As soon as the adhered sealing tape begins to touch the other corner post, apply an aluminium connecting strip at the correct position in the channel between the corner posts. Start with the seam in the base and make sure that there is a coupling accessory to the left and right of the connecting strip to be screwed on.

Pull the sections further together until the entire length of the connecting strip sits in the channel. Then screw on the connecting strip using the round-headed sheet metal screws supplied (6.3 × 13 mm). The number and position of the connecting strips depend on the dimensions of the air handling unit and are shown in the following table.

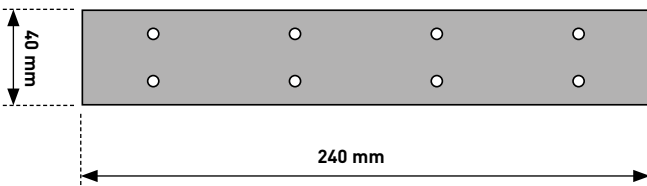

Figure 10 Connecting strip

Internal unit width or height [module (mm)]	Number of strips per side [-]	Distance a to walls of air handling unit [mm]	Centre-to-centre distance L between the strips [mm]
10 (612)	1	306	-
15 (917)	1	459	-
20 (1222)	1	611	-
25 (1527)	2	382	763
30 (1832)	2	458	916
35 (2237)	2	559	1119
40 (2542)	3	424	847
45 (2847)	3	475	949
50 (3152)	3	526	1050
55 (3457)	4	433	864
60 (3762)	4	470	941
65 (4067)	4	508	1017
70 (4372)	4	547	1093

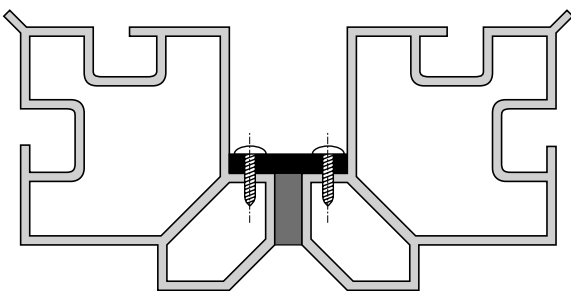

Figure 11 Coupling member between the enclosure sections

Now move the aluminium accessories to the correct position for applying the next connecting strip. When applying the strips on to the vertical seam, it is advisable to start with the bottom strip.

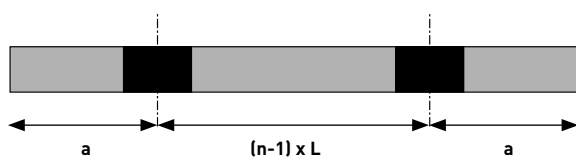

Figure 12 Distribution of connecting strips

6

Assembly of sections

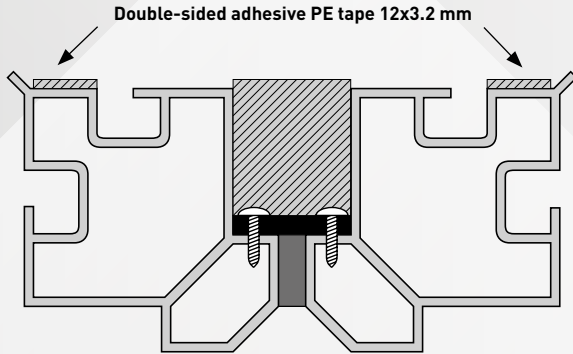

Figure 13 Insulating the seam

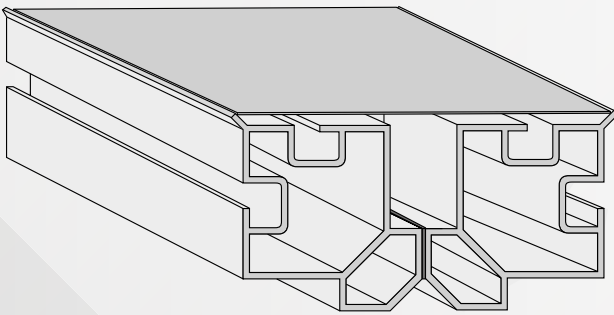

Figure 14 The unit sections are seamlessly joined

D After all the strips have been mounted, the insulating strips (40 × 35 mm) included must be inserted into the channels between the corner posts. Press the insulating strips into the channels as much as possible until about 3 mm continues to stick out. With the supplied cover plates and the supplied double-sided adhesive PE tape (12 × 3.2 mm), the seams can be finished flush with the inner panels, according to the following procedure.

- Apply the double-sided adhesive PE tape along the slanted edges to the corner posts (see figure 13).
- Cut the cover plates, included in the delivery, to the correct length. Remove the protective layer from the PE tape and stick the cover plates on the adhesive tape between the slanted edges of the corner posts.
- Press the cover plates firmly along the edges.
- Seal the seams in the corners with a suitable type of mastic. It is recommended that you seal the longitudinal seams of the plates. If the longitudinal seams are not sealed, then the cover plates must be secured to the uprights with individual screws. Apply the screws to the edge of the cover plates.

E The unit sections are now virtually seamlessly joined. Where high hygienic requirements are demanded, the seams between the cover plates and the slanted sides of the corner posts can be sealed as well!

7

Connections

7.1. General

The air ducts and build-in components shall be mechanically and electrically connected by skilled personnel in compliance with these installation instructions and the current regulations (professional practice). Lead-throughs in the casing construction for electrical connection of built-in components shall be equipped with suitable cable glands and, where necessary, additional seals to prevent air leaks.

Cabling and lead-throughs close to hatches/doors, panel edges and panels for heaters and coolers shall be avoided.

Liberty Composite AHU gives no warranty on equipment supplied and incorporated by third parties, nor on built-in electrical components supplied by the client and built in by Liberty Composite AHU. This also applies to any consequential damage ensuing from this, such as damage to the air handling unit or to built-in/ added components. After the entire air handling unit is installed on site, the steel hoisting pipes protruding from the base frame must be removed. The holes in which the hoisting pipes were mounted can be sealed off with the plastic caps included in the delivery.

Hoisting pipes subject to a deposit scheme must be returned to Liberty Composite AHU, after which they will be discounted.

7.2. Air duct connections

Air ducts that must be connected to the intake and exhaust openings of the air handling unit shall preferably have the same inner dimensions as the size of the unit openings.

Bends or abrupt reductions in the immediate vicinity of the openings must be avoided as much as possible. Duct connections on the air handling unit must be established according to commonly applied technical regulations. The air ducts may not be supported by the unit but must have their own structure to bear the weight. The duct sections must be attached to the openings tension free, even when a flexible connector is used. The external insulation shall be extended to the corner posts to prevent condensation on the duct connection.

Air handling units with a high heat-recovery efficiency under humid return-air conditions, such as a pool unit, can cause the components on the exhaust-air side to cool down significantly. The exhaust-air ducts must be made of a suitable material and must be able to drain condensate.

7.3. Connecting water coils

Connect the coils to the supply and return pipes of the hot water or chilled water system as indicated by arrows or text on the coil connections.

Always make sure that the air handling unit remains freely accessible for maintenance. At the time of installation, especially of pipes, make sure that the inspection panels can be removed at any time.

If the coil is not fitted with air vents and drain plugs, the installer must install them in the pipe system. It is preferable to connect the heater and cooler in such a way that the coil

7

Connections

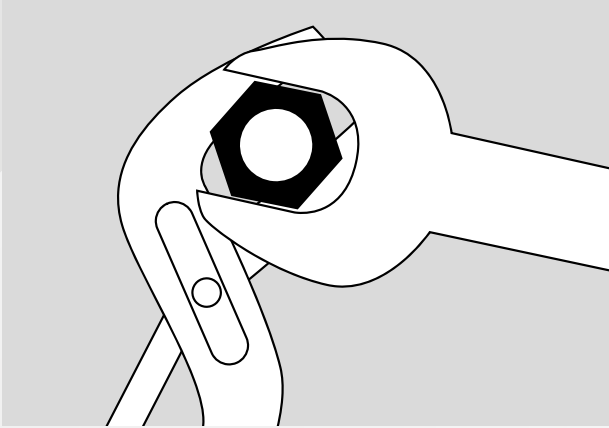

Figure 15 Connecting the coil

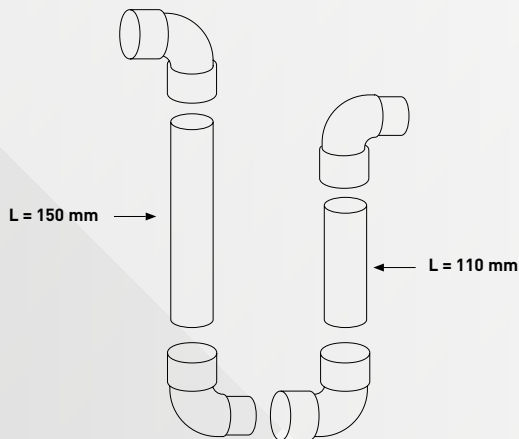

Figure 16a Connecting the positive-pressure siphon

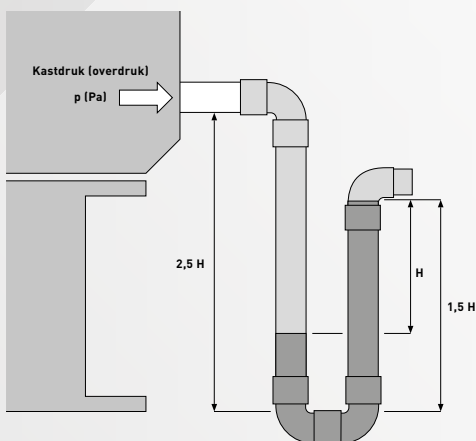

Figure 16b Connecting the positive-pressure siphon

can vent in the flow direction of the medium. If the return pipe runs downwards instead of upwards, it is recommended to add an air collector in the pipe system at the coil outlet.

The coil must be connected using tools suitable for this purpose, such as a pipe wrench, in order to prevent damage.

Make sure that when tightening a coupling or flange on a threaded coil connection, the tightening torque is compensated by a reverse torque using a suitable wrench. Extend the insulation of the connection pipes of the cooling coil until it is against the unit wall and finish vapour-tight.

The maximum operating conditions such as pressure and temperature may never exceed the permissible values according to factory specifications.

The coil shall be protected from freezing if there is risk of frost. The mixing ratio of water and antifreeze must be checked for installation components designed for functioning with an antifreeze agent. If a frost protection thermostat is installed, the control strategy for the whole frost protection system, including fans, multi-leaf dampers, circulation pumps, must interact correctly.

7.4 DX coils

Connect the DX coils according to the requirements stipulated by the manufacturer of the heat pump. Connect the DX coil according to the requirements set out in the F-Gas Regulation (EU) 2024/573 and with professional workmanship. Make sure the unit is protected from damage caused by soldering. Make sure that the rubber sleeves on the inside and outside of the panel, intended to seal the connection pipes of the coil air-tight, remain intact during soldering.

Take the possibility into account that sensors are installed on the internal part of the connection pipes and limit the transfer of heat to prevent damage to the sensors.

Extend the insulation of the connection pipes of the coils up to the unit wall and finish vapour-tight.

7.5 Run-around-coil systems

Connect the coils of the run-around-coil system as described in Chapter 7.3.

The pipe system shall be fitted by the installer. Liberty Composite AHU is not responsible for the technical implementation of the pipe system.

Extend the insulation of the connection pipes of the cooling coil until it is against the unit wall and finish vapour-tight. After the complete pipe system with appurtenances has been installed and connected to the coils, the entire system shall be filled with the correct mixing ratio of water and glycol, as described in the Liberty Composite AHU technical specifications. Too much or too little glycol can result into lower efficiency or freezing of the coils, respectively.

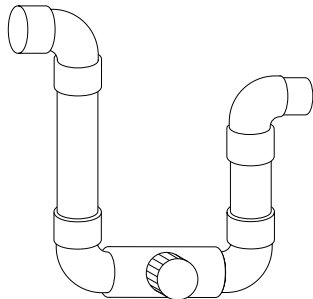

discharge side of the swimming pool unit

7.6 Siphons and water drain lines

A siphon must be connected to every (condensation) drain line. Multiple drain pipes may not be connected to a shared siphon.

The siphons must drain into the sewer without any pressure. Incorrect connection of the siphons with their drains can result in flooding in the air handling unit and/or the plant room.

7.6.1. Positive pressure siphon

The positive pressure siphon is a so-called U-trap. This siphon can handle a maximum pressure of 800 Pa. Fill the siphon completely with water after installation. When the unit is started up, the siphon will automatically adjust to the correct level. Shall the siphon not be filled or ever dry up, the condensation water will bring the water up to the correct level over time. However, the siphon must be filled after extended standstill periods to ensure that it functions properly immediately after start-up.

If there is not sufficient height available to install this siphon, it can be shortened in certain cases, depending on the pressure level in the unit. Positive pressure at that position shall be taken into account.

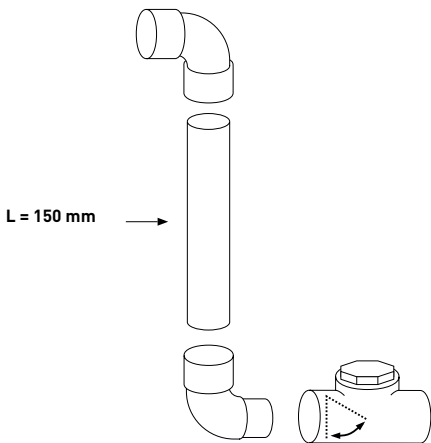

$$H \text{ [mm]} = \frac{\text{Positive pressure in AHU [Pa]}}{10}$$

7.6.2. Negative pressure siphon

The negative pressure siphon, also called vacuum siphon, is a so-called valve siphon. This siphon can handle a maximum pressure of 1000 Pa. The siphon does not require filling with water after installation. When the unit is started up, the siphon will automatically adjust to the correct level. Even if this siphon would dry up, the valve ensures that no air would be taken in through the drain line.

If there is not sufficient height available to install this siphon, it can be shortened in certain cases, depending on the pressure level in the unit. Negative pressure at that position shall be taken into account.

$$H \text{ [mm]} = \frac{\text{Negative pressure in AHU [Pa]}}{10}$$

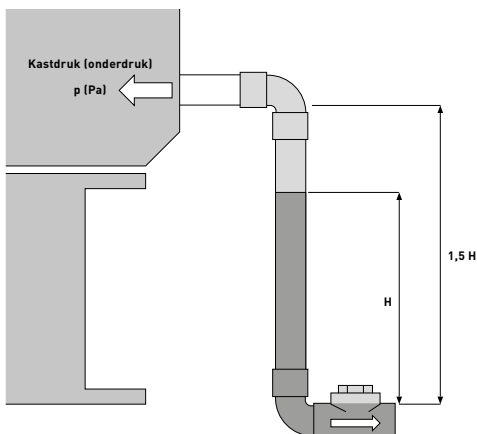

Figure 17 Connecting the negative-pressure siphon

7.7 Electric heaters

Air handling units equipped with an electric heater shall be connected according to the current electrical engineering directives. Connect the electric heater as indicated on the wiring diagram included in the delivery.

7

Connections

Connecting an electric heater requires extra attention, and non-compliance with the directives can result in damage to the air handling unit and the building in which the unit is installed.

The use of the electric heater entails the following risks:



The electric heater is a voltage conducting component. Consequently, the steel casing of the heater must be earthed correctly.



The electric heater has parts that become hot, which should not be touched. Some of the generated heat will radiate into the immediate surroundings.

An electric heater requires a minimum air velocity in order to transfer the generated heat to the supply intake air. The heater includes 2 circuit breakers which interrupt the power supply at 90 °C and 120 °C, respectively (clickson). When the highest temperature is exceeded, the heater will no longer be functional until the reset button on the side of the heater is pressed.

The electric heater may only be started up if sufficient air flow passes over the heating rods (nominal flow). The fan may never be switched off simultaneously with the heater, but must continue operating for at least another 3 minutes to remove any accumulated heat!

For speed-controlled fans, the capacity of the heater must decrease in proportion to the fan speed.

The operating protocol above must be realised with control equipment with the right sensors and settings.



Failure to comply with this operating protocol can result in situations posing a fire hazard and serious damage to the entire air handling unit!

7.8 Humidifiers

Water and steam humidifiers are available in many versions and must be connected according to the installation instructions of the humidifier manufacturer.

If the humidifying unit is equipped with a drip tray, connect the siphon to it as described in 7.6.

By means of an adequate control system, it must be guaranteed that the relative humidity downstream the humidifier will never be higher than the design value in Liberty Composite AHU's technical specifications or the design value stipulated by the manufacturer of the humidifier.

For additional protection, a maximum humidistat shall be installed at sufficient distance downstream the humidifier, which switches off and blocks the humidifier when it is activated. Excessive relative humidity downstream the humidifier can result in flooding in the air handling unit and/or the plant room.

Liberty Composite AHU does not give any warranty on humidifiers built in by the client. This also applies to any consequential damage ensuing from this, such as damage to the air handling unit and unit lead-throughs.

7.9 Electrical connections

The air handling unit can comprise a number of electrical components. Working on electrical components is a safety risk and should be done by skilled personnel. The plastic air handling unit will in most cases function as an insulator.

Partly for this reason, all electrical components have to be correctly earthed. Correct earthing is partly decisive whether the electrical and/or electronic component can function correctly.

Liberty Composite AHU does not give any warranty on damage to electrical components caused created by incorrect earthing.

7.9.1 Fan with standard motor

Fans with a standard motor consist of a fan wheel or impeller and a steel structure on which the standard motor is mounted, directly or indirectly attached to the impeller. Direct-driven fans will have to be adjusted to the fan speed for the operating point as stated in the technical specifications of the air handling unit by means of a frequency inverter. This fan speed can be higher or lower than the nominal rpm speed of the motor. The data on the motor plate are normative for the nominal values of the motor. (see also 7.9.3 frequency inverters)

An indirect-driven fan has a belt transmission between the standard motor and the impeller. By selecting the correct diameter ratio of the belt pulleys, this transmission can (within narrow tolerances) ensure that the operating point of the fan is reached at the nominal speed of the motor.

7

Connections



However, according to EU regulation 1253/2014, a frequency converter must always be used for indirect-driven motors as well in, order to comply with the legal requirements for CE marking.

In addition to a power supply connection, a direct or indirect-driven fan is usually equipped with a PTC motor temperature surveillance sensor embedded in the motor windings. This sensor shall be wired separately from the power supply and ensure that the motor is switched off when activated.

After connecting, check the direction of rotation of the fan and the absorbed motor current. (see also 7.9.3 frequency inverters)

7.9.2 Fan with EC motor

Fans with an EC motor consist of a fan wheel or impeller and a steel structure or suspension construction with a direct connection between the motor and the impeller. The electronic control is usually integrated into the motor and both components are required to run the fan.

Connect the main power supply (1~ 230V of 3~400V) and the earthing to the maintenance switch or the terminals on the motor. The control current shall be cabled separately from the main power supply. The electronic control must be set on the operating point by means of the contacts (or via the bus connection by means of the Modbus protocol). The direction of rotation is not affected by the sequence of the phases. Several fans can be mounted in the fan section. Each fan then has its own maintenance switch.

7.9.3 Frequency inverters

Frequency inverters serve to set a fan with standard motor at the desired operating point. The frequency inverter can be delivered separately or pre-installed and cabled to the motor. For connecting and adjusting the inverter, see the documentation from the supplier and follow the instructions. Select a frequency inverter suitable for the power of the motor and which rules out the risk of bearing currents and complies with the EMC directives. After connecting, check the direction of rotation of the fan and the absorbed motor current. The direction of rotation of the fan is changed by changing the sequence of the phases at the output of the regulator.



The frequency inverter is a voltage-conducting component. The casing of the inverter must therefore be earthed. The inverter can hold a residual voltage after it has been switched off.

A frequency inverter installed and cabled by Liberty Composite AHU has a maintenance switch (EMC version) in the main power supply between the frequency inverter and the motor. The PTC of the motor is connected to the inverter and is cabled separately from the main power supply, just like the connection of the control current.

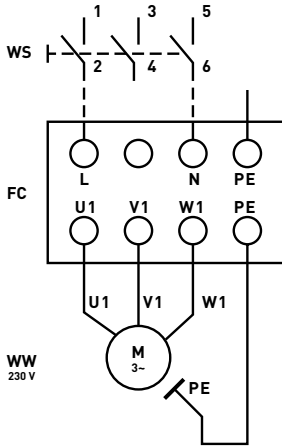

Figure 18 Connecting maintenance switch WS in position 1-5-PE

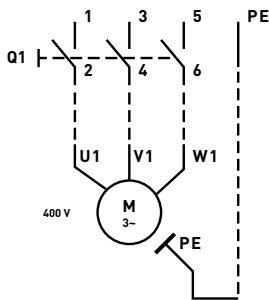

Figure 19 Connecting maintenance switch Q1 in position 1-3-5-PE

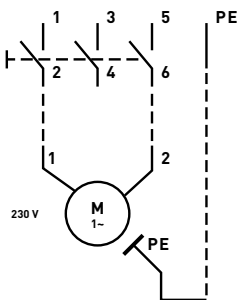

Figure 20 Connecting maintenance switch Q1 in position 1-5-PE

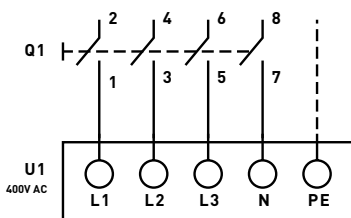

Figure 21 Connecting maintenance switch Q1 in position 1-3-5-7-PE

7.9.4 Rotary heat exchanger

The frequency inverter (FC) controlling the rotational speed of the rotary heat exchanger is available in different types. The control current connection for all designs (see the manufacturer’s documentation) shall be cabled separately from the main power supply. Connect the power supply to the maintenance switch as shown in the illustration. The direction of rotation of the motor for the design with standard motor can be changed by changing the sequence of the phases at the output of the inverter.



The frequency inverter is a voltage-conducting component. The casing of the inverter must therefore be earthed. The inverter can hold a residual voltage after it has been switched off.

7.9.5 Maintenance switches

Maintenance switches are installed in the immediate vicinity of the inspection hatch of a fan section and serve to connect the main power supply of the fan or other electrical components.

Maintenance switches on the air handling unit shall be used when maintenance, repair and cleaning (see OH&S Act Article 7.5.2) are carried out. The maintenance switches are designed as load separators and interrupt the main power supply (power interlocking).

Changes made by or changes at the request of the customer from a main power supply to a control current isolation switch shall be made according to NEN-EN IEC 60204-1. In all cases a maintenance switch serves to prevent the component in the air handling unit from being switched on inadvertently. Checking of the functionality of the maintenance switches shall be always included in maintenance of the air handling unit.

7.9.6 Actuators

The power of the actuators is so low that it does not require additional protection. A single phase 230 V or 24 V connection suffices. Before start-up, always check whether the multi-leaf dampers are functioning correctly. Where possible, check if the damper blades do not rub against the casing or touch any flexible connections.

7.9.7 Integrated control

The control panel of the integrated controls includes connections for measuring, regulating and protecting the components in the air handling unit. Components and field equipment outside the air handling unit shall be connected and cabled according to the control diagram. The control panel receives its power via a maintenance switch (see figure 18). Check the connections to the maintenance switch before starting up the controls.



The integrated controls are voltage conducting components. The casing of the controls shall be earthed correctly by means of the maintenance switch. The control panel shall be locked during regular operation.

8

Commissioning

8.1. General

The air handling unit may not be started up until all work and inspections described in this chapter have been completed!

Before work is started, all maintenance switches must be set to the off position and locked. All hydraulic and electrical connections to the relevant components shall also be available and the air handling unit shall be connected to the duct system.

8.2 Damper registers

Check that the blades of the dampers can rotate freely and do not rub against the casing, flexible connections or ducts.

Check that the actuators open and close the dampers correctly.

Closed dampers can cause (excessively) high pressures in the air handling unit or the duct system if the fan is switched on.

Before start-up, dampers with air density class 4 according to NEN-EN 1751 (DIN 1946) must be lubricated at all hinging points with a suitable lubricant with durable adhesion (e.g. Kelfort Vaseline spray or equivalent).

8.3 Filters

Air filters protect the air handling unit and the duct system against contamination and have a big impact on the air quality in the building.

Inspect the filters for damage in the filter medium and verify that the filter elements are correctly installed in the filter frames. Make sure that the measuring hoses in place are not pinched off.

Take into account that the service life of the filters is seriously reduced after initial start-up of the unit due to excessive dust loads in the air and other building pollution.

If the air handling unit has also been running during the construction period, we recommend replacing all filters after commissioning, as described in Chapter 9.

There are several options for preventing this:

- Temporarily replacing the filters included in the delivery with ePm10 filters. These filters can arrest enough dust without collapsing immediately (as is the case for ePm1 filters). ePm10 filters protect the air handling unit adequately that it will not be contaminated.
- Thoroughly cleaning the building and the air handling system before initial start-up.

8.4 Cross-flow / counter-flow plate heat exchanger

Cross-flow plate exchangers and counter flow exchangers are started up in a similar way. Thus the term “cross-flow exchanger” can also be read as “counter flow exchanger.” The plate package of a cross-flow exchanger is made of thin aluminium plates and is susceptible to mechanical damage. Minor damage (bent plates) is easy to repair by bending the plates back to their original shape by hand.

Check the seals round the cross-flow exchanger on the wall of the air handling unit. The seals can shift somewhat during transport.

Most cross-flow exchangers are equipped with face and by-pass dampers to control the capacity. In addition the exchanger can also be fitted with a recirculation damper. Check that these dampers rotate easily and do not rub against the housing and that the actuators open and close the dampers completely.

Incorrectly functioning dampers can have a very negative effect on the efficiency of the cross-flow exchanger!

8.5 Rotary heat exchanger

A rotary heat exchanger is sealed along the circumference of the wheel and sealed radially to minimise leakage between the two air flows. The peripheral seal can be affixed to the rotor or the housing. Furthermore, the rotary heat exchanger can be provided with a rinsing purging sector which ensures that the rotor matrix is blown clean with outside air before the rotor part is inserted in the intake air.

The rotary heat exchanger is driven by a motor ④ with a belt ② passing over the belt disc ③ and over the circumference of rotor ①. The belt is held under tension by a coil spring ⑥ under the hinged mounting plate ⑤ of the motor.

The direction of rotation of a rotary heat exchanger with purging sector must be selected in such a way that the rotor turns from the rinsing zone of the exhaust air into the intake air. In the illustration, the pulley ③ is rotating clockwise.

Instead of a drive motor with gearbox as shown above, a fixed drive motor without gearbox may be fitted, for example, with a round belt. Before final commissioning of the rotary heat exchanger, the belt tension must be checked and, if necessary, adjusted by shortening the belt. The method of shortening depends on the type of drive belt.

Rotary heat exchangers that are only finally commissioned at a later stage may not remain in the same rotor position for more than two months. It is thus recommended to already connect the voltage to the controller. As a result, this will activate the pulse-pause function and change the rotor position regularly. If it is not possible to connect the voltage to the controller, then it is advisable to turn the wheel 90° every month.

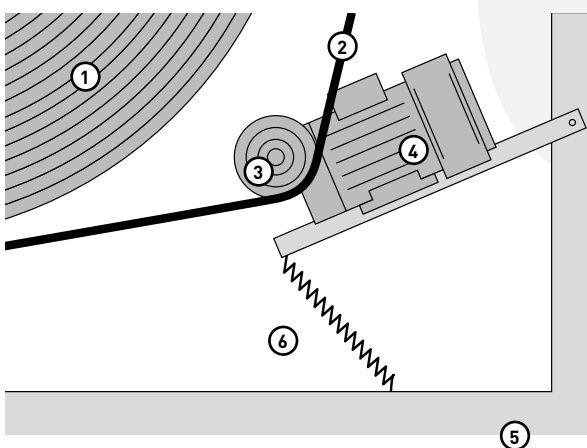

Figure 22a Rotary heat exchanger and motor

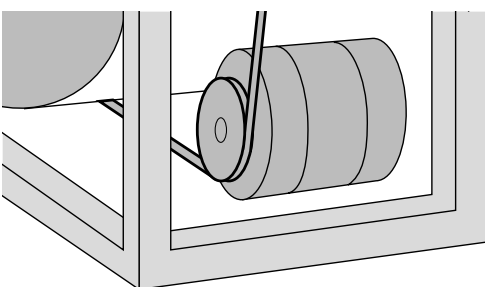

Figure 22b Fixed drive motor without gearbox

8

Commissioning

The pulling part of the belt of rotary heat exchangers without purging sector must correspond with the centre line through the pulling spring as much as possible. The direction of rotation is usually indicated on the rotary heat exchanger.

The direction of rotation must be checked at the start-up! The direction of rotation can be reversed by inverting the 2 phases on the connection to the motor and/or controller.

The seals can shift during transport.
The seals must be readjusted at the start-up.

8.6 Run-around-coil systems

Run-around-coil systems must be filled with a water-glycol mixture in the correct mixing proportion (see also 7.4). Check that the system is filled with the right glycol concentration.

Furthermore, the instructions for start-ups as described for water coils shall be observed.

8.7 Water coils

Check that the direction of flow of the medium through the coil corresponds with the arrows on the coil connections. The direction of flow must always be such that water and air are in counter flow. Incorrect connection will result in loss of capacity of the coil.

Water coils are equipped with thin aluminium fins that are susceptible to mechanical damage. Minor damage does not affect the capacity of the coil.

However, if the fins are warped over extensive surface areas, this will affect the performance. Bent fins can be "combed" with a special tool so that they are practically restored to their original shape.

A plate comb is suitable for various fin spacings, as shown in the illustration.

Make sure that the correct fin spacing is selected when a plate comb is used, equal to the fin spacing of the fins on the coil.

Check that the hydraulic system is filled with the correct medium (water) and ensure that the coil with the connecting pipe system is completely vented by opening the venting taps until only water flows from the taps.

An unvented coil does not deliver the full capacity and can result in uneven temperatures in the unit cross section.

8.8 Electric heater

Check the electrical connections to the heating elements and the connection of the protective thermostats based on the corresponding wiring connection diagrams.

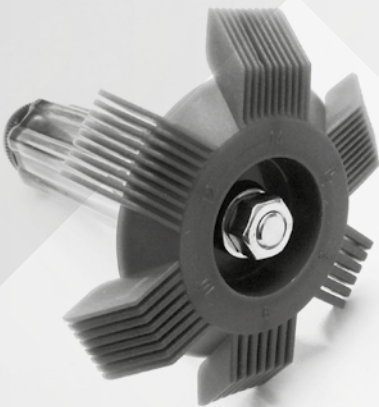

Figure 23 Plate comb

Test the following control safety provisions for the correct functioning:

- protective thermostats
- flow switch for heater enabling
- post run time for fan(s)

Check to make sure that no paper or other flammable objects were left in the unit. These could catch fire immediately due to the high temperature of the heating rods.

8.9 Siphons and water drain lines

Check that the right type of siphon is connected to every drain line of the drip tray(s).

Drip trays in unit sections with negative pressure during normal operating conditions must be provided with a negative pressure siphon, and drip trays in unit parts with positive pressure must be equipped with a positive pressure siphon. Check that no dirt ended up in the siphons during the construction phase. If necessary, clean dirty siphons with water. Pour a quantity of clean water in the drain opening of the drip tray(s) in the positive pressure sections until water flows from the positive pressure siphon.

Lastly, check whether every siphon can flow freely into the sewer.

Incorrect installation and inspection of the siphons as described in 7.5 and in this chapter can result in flooding in the air handling unit and in the plant room as well as possible water damage to the building!

8.10 Fans

Before starting to undertake an inspection of the fan, the maintenance switch must be moved to the off position and locked. Only open the hatch or door after the fan has come to a complete stop.



Caution! The fan motor may be hot.

8.10.1 Direct-driven fans

Direct-driven fans can be equipped with a standard motor or an EC motor.

Check that the wiring is correctly connected to the maintenance switch of the motor according to the wiring diagram.

Standard motors are controlled by a frequency converter. Also check that the electric cabling is connected to the terminals of the frequency inverter according to the supplier's wiring diagram.

Direct-driven fans can be mounted on a vertical wall or on the bottom of the air handling unit. Remove any transport protection from fans mounted on the bottom and check whether the flexible connection is not installed too tightly or pushed in too far. Check that all attachment bolts and nuts

8

Commissioning

have been tightened sufficiently and that the impeller can be easily rotated by hand and does not rub against the inlet cone anywhere.

Now check the direction of rotation of the fan by switching it on briefly. If the direction of rotation does not match the direction of the arrow on the fan, reverse the direction of rotation by exchanging 2 phases on the motor connection.

The direction of rotation of fans equipped with an EC motor does not have to be checked since these fans always have the correct direction of rotation!

8.10.2 Indirect-driven fans

Check that the cabling is correctly connected to the terminals of the maintenance switch or of the frequency converter according to the manufacturer's wiring diagram. Standard motors must be controlled by a frequency converter. Also check that the electrical connections to the terminals of the frequency inverter correspond with the supplier's wiring diagram.

Remove any transport protection from fans mounted on the bottom and check whether the flexible connection is not too tight or pushed in too far.

Check that all attachment bolts and nuts have been tightened sufficiently and that the impeller can be easily rotated by hand and does not rub against the inlet cones anywhere.

Check that the V belts are tensioned correctly and that the fan and the motor are properly aligned. Alignment can be checked with a steel ruler or a thin cord held along the belt pulleys. The ruler or the cord must completely touch both belt pulleys.

The requisite information concerning the V-belt tension is usually indicated on the fan.

If this information is lacking, the values in the table below can be used as a guideline.

Belt type	Test force per belt [N]	Deflection per 100mm shaft distance [mm]
SPZ	25	1.5 – 3.0
SPA	50	1.5 – 3.0

Now check the direction of rotation of the fan by switching it on briefly. If the direction of rotation does not match the direction of the arrow on the fan, reverse the direction of rotation by exchanging 2 phases on the motor connection.

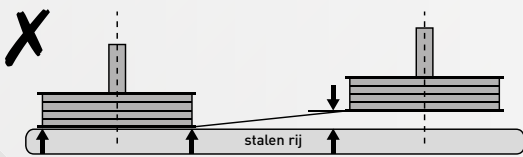

Figure 24a Alignment with a steel ruler

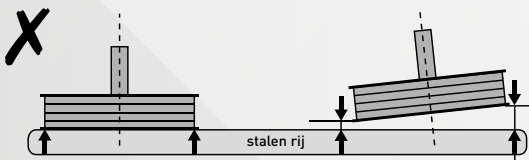

Figure 24b Alignment with a thin cord

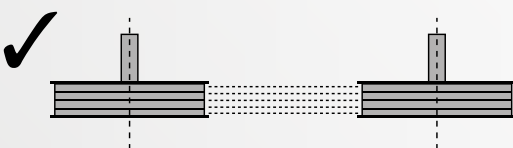

Figure 24c Optimal alignment

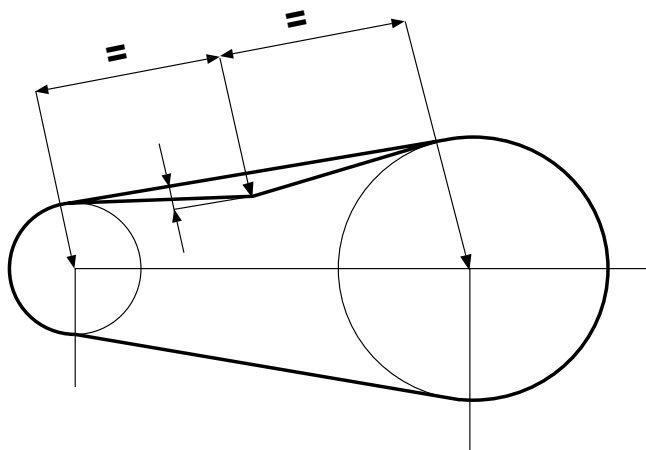

Figure 25 Deflection of the belt

8.11 Humidifiers

Due to the large variety of humidifiers available, we refer to the operating instructions from the manufacturer of the humidifier for starting up the type built in.

8.12 Test runs

Check every section of the air handling unit to see whether any objects or papers were left behind.

Close all inspection openings and make sure the hatches/doors are closed properly. Verify whether all (fire) dampers in the duct system are open and whether the volume control dampers, if present, are set to their nominal flow. After all inspections and checks described above have been carried out, the complete air handling unit can be started up and tested if there is no hazard of the water coils freezing.

Set all maintenance switches in the on position (1) and switch on the air handling unit via the normal operating command. Check that the dampers on the intake and exhaust openings open completely based on the position indicated on the actuators. The fans shall be switched on with a delay after the damper registers are completely open. Set the fan speeds to their nominal value as indicated in the technical specifications. After switching on the fans, measure the currents to the electric motors and check that these are not higher than the nominal value on the type plate of the motor.

Repeat this measurement after the air handling unit has run in stationary mode for approximately fifteen minutes. Write down the measured current in the commissioning protocol. Assess the fans for quiet operation and vibrations. The level of vibration for speed-controlled fans can be higher at specific fan speeds because the fan speed corresponds with a resonance frequency. When starting up the fans, we recommend determining the resonance frequencies and programming the matching speed ranges in the controller as "skip" frequencies.

Switch the air handling unit off if the motor continues to be overloaded or if excessive vibrations persist.

Contact the supplier if the root cause of the defect cannot be detected.

8.13 Integrated control

An integrated controller shall be started up by personnel trained for this purpose. Start-up comprises the actions described in the sections above and, in addition, a functional test of the control software and its values programmed. The integrated control shall be supplied with power according to the wiring diagram, and the field equipment drawn on this diagram shall be connected (or secured) before starting up the control.

9

Inspection & maintenance

9.1 General

The "Ventilation management and maintenance guidelines" can be used for inspection and maintenance. The Guidelines can be downloaded from the Binnenklimaattechniek website. <https://www.binnenklimaattechniek.nl/kenniscentrum/binnenklimaatrichtlijnen/>

This specification indicates for each component what the minimum maintenance frequency is and provides a brief description of what inspection and maintenance work needs to be carried out.

A checklist per component has been included in the attachment, on which all requisite inspections that were actually implemented can be ticked. In addition to the specifications of the Dutch branch organisation VLA, the following specific inspection and maintenance instructions shall be followed.



During maintenance on the unit, the maintenance switch, or if there are several fans, all maintenance switches, must be switched off to the 0 position. If any work has to be done in the unit, the switch(es) shall be locked in the 0 position with a padlock. The unit may be opened after a few minutes once the fans have stopped rotating. When carrying out electrical engineering work, the power supply to the maintenance switch(es) must also be blocked and secured according to NEN 1010 and the locally applicable regulations.

9.2 Casing

Meticulously check the dry parts, inside and outside, one time per year. For maintenance of wet parts (coolers, etc.) we refer to the relevant air handling functions. Chemical compounds formed by arrested dust particles with water droplets and aggressive sulphurous vapours in the air can cause a very corrosive fluid to precipitate on the bottom, especially underneath the filters. Wear protective clothing when cleaning this up.

9.2.1. Outdoor installation

The roof shall be checked regularly for damage and fouling such as by moss, algae, leaves, branches and other debris. In order to extend the service life of the panels, we recommend cleaning the outside with a wet cloth or sponge one time per year. A combination of car wash shampoo/wax is ideal. We absolutely advise against cleaning the air handling unit with a high-pressure cleaner.

9.2.2 Inspection panels and locks

In principle, inspection panels and locks do not require any maintenance. When the casing is inspected, the inspection panels shall be checked at the same time for possible damage, especially the double seal. Dirty panels can be cleaned with a moist cloth and, if necessary, with a special soap-based cleaning agent. Contact Liberty Composite AHU if there is serious damage to the seals.

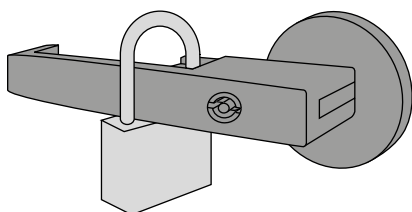

Figure 26 Padlock

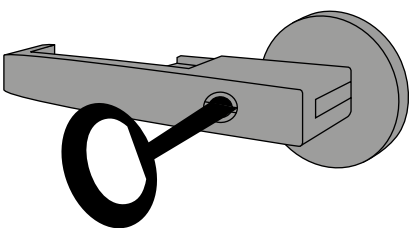

Figure 27 Locking ring lock

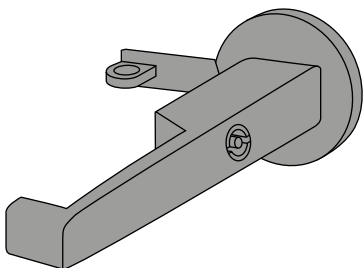

Figure 28 Handle in neutral position

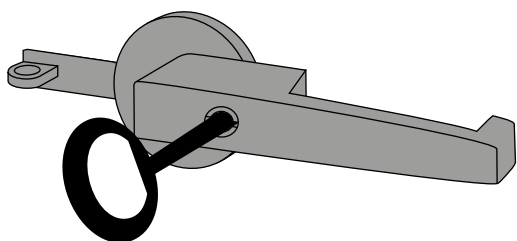

Figure 29 Handle in removal position

On request, the hatch can be fitted with hinges. When opening a hinged hatch, the handles must be set to the same position as outlined for this. Then pull the hatch forwards until the hinges move to their locked position. The hatch can now be opened like a door. The middle handle can be pushed into the clamp against the casing wall, thereby locking the 180° open position.

The locks can be locked and unlocked in various ways.

Padlock

All or several locks can be locked with a padlock (not included in the delivery). This is particularly handy if you want to ensure that no unauthorised individuals can open the air handling unit.

Machine key

A locking ring lock can be locked with the machine key (5 mm, double bit type) so that only service personnel can open the unit. The locking ring lock can be opened or locked by turning the key a quarter of a turn.

Handle in neutral position

The panel is closed when the handles are in the neutral position. The handle must be pulled forward slowly to open the panel. Make sure that the locking ring lock is unlocked. Now rotate the handle which is protruding forward at minimum a quarter of a turn clockwise or counter-clockwise. The lock is now unlocked.

Handle in removal position

To facilitate removal of the panel, the handle can be rotated half a turn and pushed back against the unit wall. Securing the lock with the machine key has created a stable handle to remove the panel

9.3 Intake and exhaust grids with droplet eliminators

Check the grids with droplet eliminators every year for contamination, correct fastening and damage. Seriously fouled grids and/or eliminator blades can be cleaned, if necessary, without dismantling them, from the outside (close the air damper behind them) and the inside, using a jet of water.

9.4 Damper registers

All hinges of the damper blades have plastic bearing bushes which do not require lubrication. Remove excessive dust accumulation by blowing the blades clean with compressed air. Check the adjustment bolts of levers and tighten them if necessary. If possible, check that the damper blades do not rub against the casing or touch the flexible connections. Check the end position of the actuators and adjust them if necessary.

9

Inspection & maintenance

Damper registers with air leakage class 4 according to NEN-EN 1751 (DIN 1946) require additional maintenance due to the composition of the material and the strict tolerances at the hinging points.

All hinge points must be lubricated at least twice per year using a suitable lubricant with durable adhesion (e.g. Kelfort Vaseline spray, or equivalent).

If the first maintenance inspection shows evidence that the damper blades are rotating with high friction as a consequence of corrosion or deposit, the maintenance frequency must be increased. Hinge points that turn with high friction can be treated with a suitable penetrating oil (e.g. WD-40 Multi-Use, or equivalent) to remove incipient corrosion. Remove any debris and moisture before lubricating the hinge points.

9.5 Air filters

Filters must be replaced at least once a year, with the exception of filters in a second filter stage. The latter must be replaced if the recommended final resistance has been reached. In a dirty environment and/or during continuous operation it may be necessary to replace the filters in the first filter stage more often. Take into account that the service life of the filters can be severely reduced after start-up due to taking in construction dust and other construction debris. Filter classes higher than ePm1 are not built in but included separately in the delivery because they become very fouled and are exposed to damage during installation or at the start-up.

9.5.1. Bag filters

The service life of bag filters is long to very long due to their structure and shape. Liberty Composite AHU always uses the standard filter dimensions 600 x 600, 300 x 600 and 300 x 300 mm in their air handling units. Check the pressure drop of the bag filters once a month. Pressure drop is the best indication of the extent to which the filters have become contaminated. $1.6 \times$ the initial resistance + 40 Pa can be used as final resistance. If the specified end resistance is reached, remove and replace the filters with clean ones. The filters are clasped in place by filter clamps. The quality of filtration is partly determined by the accuracy of positioning and sealing of the bag filters. Take care that an optimal filter surface area is obtained by hanging the filter bags vertically.

9.5.2. Compact filters

There are compact filters in the H class and ePm class filter qualities. The ePm class quality is installed like the bag filters described above. The same considerations as described in 9.5.1. apply to the service life and recommended final resistance. The same method can also be used for changing the filters. However, the installation position of the compact filter is arbitrary (V shape horizontal or vertical).

9.6 Cross-flow / counter-flow plate heat exchanger

The plate exchanger may not sustain any mechanical damage when it is cleaned. Corrosion of the unit caused by the chemical effect of cleaning agents must also be prevented. An inspection interval of approximately three months shall be used for new installations. Depending on the operating set-up this may be extended to a maximum of one year!

For air handling units in swimming pools, a lot of condensate builds up for a large part of the year and collects in the drip tray below the plate exchanger. Depending on the type and use of the swimming pool, growth of algae can occur in the drip tray as a result of which blockages may occur. The inspection interval for drip trays in swimming pools should therefore be **one month**.

Inspection

- Check the face and bypass dampers of the exchanger for correct operation (hinges of the damper blades, air tightness).
- Check the actuator for correct operation (if necessary with a forced control signal).
- Check the exchanger for damage (frost damage), debris and deposits in the plate package and the bypass duct.
- Check the drip tray for fouling upstream and downstream of the exchanger.
- Check the siphon for fouling and correct operation and fill with water, if necessary.
- Check droplet eliminators, if present, for fouling.
- Check that the droplet eliminator blades are still mounted in the correct position.
- Check the seals between supply air and exhaust air for air tightness.

Maintenance

- Clean the dust and fibres fouling the plate exchangers using a vacuum cleaner or soft brush.
If it is necessary to blow compressed air through the exchanger pack, maintain an adequate distance in order to avoid damaging the plates.
- Plate exchangers fouled with oil, grease and other sticky deposits can be cleaned with hot water (do not use steam) and/or non-corrosive grease-dissolving cleaning agents. When using a high pressure cleaner use a flat sprayer (40°) with a maximum water pressure of 100 bar at adequate distance from the plates.
- Clean fouled drip trays and siphons with hot water and/or non-corrosive grease-dissolving cleaning agents. Remove any water or cleaning agent from the walls of the air handling unit with a dry cloth so that no residue is left.
- For air handling units in swimming pools, it may be necessary to clean not only the drip trays and the siphons, but also the discharge pipe after the siphon. Especially in horizontal pipes, where there is standing water, algae growth can also occur. The pipe can best be cleaned by disconnecting it and allowing a cleaning agent to soak in for a while. Then flush the pipe thoroughly with warm water for a few minutes and reconnect to the siphon of the drip tray.

9

Inspection & maintenance

9.7 Rotary heat exchanger

Before starting any inspection and/or maintenance of the rotary heat exchanger, the voltage to the drive motor must be switched off. When cleaning the rotary heat exchanger, the rotor must not be mechanically damaged. It is also important to avoid the material from being affected by the chemical effect of cleaning agents.

An inspection interval of approximately three months shall be used for new installations. Depending on the operating situation, the interval may be extended to a maximum of one year!

Inspection

- Check the tension of the drive belt. Carry out the first inspection after approximately 100 operating hours.
- Check the electric motor and gear unit for grease leaks and possible oil leaks.
- Check the motor bearings and rotor bearings for clearance and bearing noise.
- Inspect the electrical connection for damage.
- Check the drive belt for damage.
- Check that the drive belt connection link is operating properly.
- Check the peripheral seal and radial seals for wear and leaks (distance between sealing surfaces).
- Check the housing and rotor for damage, fouling and corrosion.
- Check the seals between the housing and unit walls for air tightness.

The rotation of the rotary heat exchanger causes dynamic loading. That's why it is necessary to periodically inspect the rotor structure.

Rotors made out of a single piece must be inspected for hairline cracks when welding. They can occur in places where the spokes are welded into the peripheral plate and at the weld of the peripheral plate itself.

Segmented wheels are fitted with peripheral plates with which the rotating parts are kept in their place. After about two weeks of operation, the bolts in the peripheral plates need to be re-tightened.

When re-tightening, alternate opposing bolted connections must be tightened. The tightening sequence is indicated in the accompanying sketch!

After this, it is important to periodically check whether the bolts have been tightened sufficiently securely. The recommended tightening torque is 35 Nm (M8) or 45 Nm (M10).

Maintenance

- Clean the rotor fouled with dust and fibres using a vacuum cleaner or soft brush. If it is necessary to blow compressed air through the rotor matrix, maintain adequate distance in order to avoid damaging the rotor material.

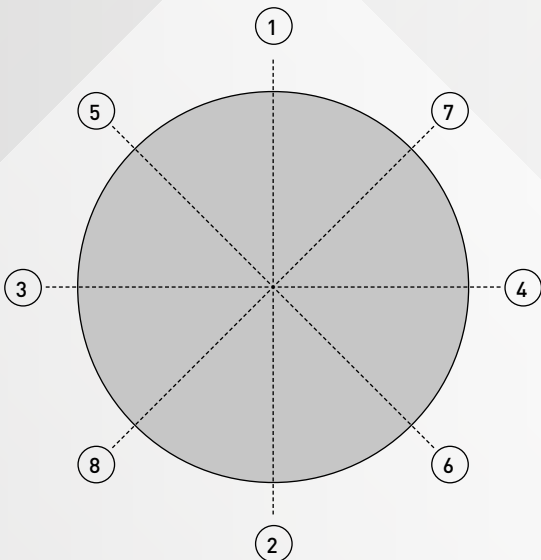

-
-
- Rotary heat exchangers contaminated with oil, grease and other sticky deposits can be cleaned with hot water up to a maximum of 70 °C (do not use steam) and/ or non-corrosive grease-dissolving cleaning agents. Preferably remove the rotary heat exchanger to do this (complete housing including the wheel can be pulled out via the operating side) and clean it outside the air handling unit, unless the water or cleaning agent can be collected adequately! When using a high pressure cleaner use a flat sprayer (40°) with a maximum water pressure of 100 bar at adequate distance from the rotor. Only use this cleaning method if cleaning can take place outside the air handling unit!
 - Remove any water or cleaning agent from the walls of the air handling unit or from the inside of the housing of the rotary heat exchanger with a dry cloth, so that no residue is left.
 - Replace any damaged or worn-out seals, drive belt and cabling.
 - Adjust the drive belt to the correct tension.
 - Tighten the bolt connections and the tensioning bolts in the peripheral plates of the split rotary heat exchanger as required (tightening torque 50 Nm).
 - Adjust any seals on a rotating rotor in such a way that leakage is minimal.
 - Clean any fouled inspection components up- and downstream the rotary heat exchanger.

9.8 Run-around-coil systems

Run-around-coil systems are to be inspected at least once a year. Check that the entire system is filled with the right water-glycol mixing ratio, as described in the Liberty Composite AHU technical specifications. For other inspection and maintenance work see also Chapter 9.9.

9.9 Water coils

Check the air intake side for fouling once a year. If necessary, after dismantling, clean with compressed air or a water jet against the direction of air flow. Check the filters and/or their positioning if the coils are seriously fouled. Condensation can occur on cooling coils and in the extract part of a run-around-coil system. Examine whether the condensation drain pipe can drain the water sufficiently.

Fouling on the water side will hardly occur. Only specialised companies can remove such fouling.

Water-filled heaters are often fitted with a frost protection thermostat. At the start of the winter season, check the frost thermostat settings and whether the correct control measures are taken when the thermostat is triggered.

Heat exchangers filled with glycol shall be checked annually for the percentage of glycol actually present in the water.

9

Inspection & maintenance

9.10 DX coil

Carry out inspection and maintenance of a DX coil as described in 9.9 Work performed on the refrigeration part must be conducted by an authorised refrigeration company.

9.11 Electric heater

Inspect the electric heater at least once a year, and check it for correct functioning. Dry clean electric heaters with a brush, vacuum cleaner and/or compressed air.

Cleaning with water or cleaning agents is not permitted and can result in short-circuiting the electrical part. Test the control equipment provisions to ensure they are functioning properly as described in 8.8.

9.12 Siphons and water drains

At least once a year, check whether the siphons are still functioning properly. Clean the siphons with water and refill them with water. The siphon must also be filled with water after a long time of standstill.

9.13 Fans



Before the fan can be inspected and maintained, the maintenance switch must be moved to the off position and locked. Only open the hatch or door after the fan has come to a complete stop. **Caution! The fan motor may be hot.**

Check the vibration mountings and flexible connections for rupture and damage once a year. Check all nuts and bolts as well as the attachment of the flexible connections to the flanges of the fan and unit wall. Check the fan for balancing once a year. Remove dust accumulation from the inlet cone and impeller. Fouling of the impeller can result in increased imbalance. In case of serious fouling, check the filters are functioning and improve the filter class quality, if necessary.

9.13.1 Direct-driven fans

The maintenance frequency for direct-driven fans is a minimum once a year.

Check the impeller, the electric motor, support structure and electrical wiring for fouling, damage and for loose attachments. Rotate the impeller by hand and make sure it does not rub against the inlet cone anywhere.

Repair any defects encountered and pay special attention when cleaning the impeller that the balancing weights remain in their original position.

Test run the fan as described in 8.12.

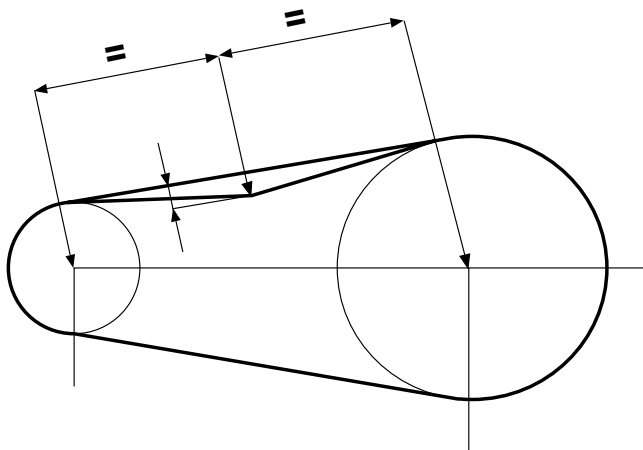

Figure 30 Deflection of the belt

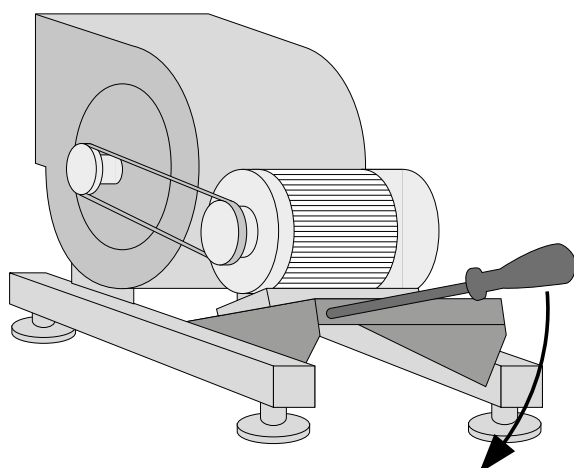

Figure 28 Tightening with a screwdriver

9.13.2 Indirect-driven fans

A maintenance frequency of a minimum of two times per year is recommended for indirect-driven fans.

Check the impeller, the electric motor, support structure and electrical wiring for fouling, damage and for loose attachments. Rotate the impeller by hand and make sure it does not rub against the inlet cone anywhere.

Inspect the V belts and belt pulleys for wear and check the alignment of the belt transmission and the belt tension as described in 8.10.2.

Repair any defects encountered and pay special attention when cleaning the impeller that the balancing weights remain in their original position.

The following method can be used for maintenance of the transmission.

Check the belt tension after start-up, and also after installing new belts, within a week, and subsequently two weeks afterwards, and adjust the tension if necessary. Check the belt tension every three months thereafter and inspect the quality of the belts. The correct V belt tension depends on the type of belt, the power to be transmitted and the belt speed. These must be calculated separately for every transmission. Excessive belt tension can result in increased bearing wear and vibrations; insufficient belt tension can result in belt slipping and wear on the belt.

The rated deflection in the middle of the belt, subjected to a test force will, on average, be as presented in the table below.

Belt type	Test force per belt [N]	Deflection per 100mm shaft distance [mm]
SPZ	25	1.5 – 3.0
SPA	50	1.5 – 3.0

Check that the belts do not rub against the belt guard, if installed. The V belt pulleys installed are fitted with tapered bushings and can be exchanged without special tools. For multi-belt drive, all belts must be replaced at the same time. The pulleys are removed as follows:

Loosen the Allen bolts and remove them, then screw one of the bolts as removal screw into the recessed hole of the belt pulley. Tightening the bolt will cause the V belt pulley to separate from the tapered bushing.

Assembly takes place as follows: Insert the tapered bushing into the pulley and make sure that the holes in pulley and bushing match; screw the Allen bolts in loosely. Slide the unit onto the shaft, align it and tighten the bolts evenly.

Standard V belt-driven centrifugal fans are equipped with a motor seat tensioning device. The motor is positioned on a hinged plate for this purpose. Loosening the plate at the back allows it to hinge towards and away from the fan. When tensioning the belt, the motor seat can be tightened further by inserting for example a heavy screwdriver into the back of the

9

Inspection & maintenance

motor seat. The tensioning device is not executed as a tension slide rail with adjustment bolts because the chance that the belt is subjected to too much force is high in that case, causing bearings and belts to wear excessively.

It is not advisable to change the fan speed without consulting the supplier. If you wish to increase the fan speed, carefully examine whether the available motor power is sufficient. The load on the bearings as well as on the impeller shall be re-calculated by the supplier.

9.14 Humidifiers

Due to the large variety of possible types of humidifiers, we refer to the operating instructions of the humidifier's supplier for inspection and maintenance of the type built in.

9.15 Noise attenuators

The noise-attenuating splitters do not require any maintenance under normal circumstances. Nevertheless, we recommend checking the absorption material of the splitters once a year for possible damage and for fibres coming loose in order to prevent clogging further down in the installation. Any fouling can be removed with a vacuum cleaner.

9.16 Controls

The controls must be checked and/or corrected annually for:

- Functioning of the entire unit.
- Functioning of all components such as sensors and actuators.
- Motor currents and settings of thermal protection devices.
- Possible damage to all components, cabling, etc.



Elandlaan 8
NL-3734 CP Den Dolder
The Netherlands

+31 (0)30 274 82 82
export @liberty-ahu.com

www.rosenberg.nl/en