

# Frost protection thermostat JTF-1 ... -25

Capillary system, 1 or 2 stages, TÜV tested, switching type



## Technical data

<b>Switching difference:</b>	15 (8) A, 24–250 V~, min.150 mA at 24 V~
<b>Switching difference:</b>	1 K
<b>Control range:</b>	–10... +12°C
<b>Contact:</b>	1 or 2 microswitches as potential-free changeover contacts
<b>Degree of protection:</b>	IP 40, W types: IP 65
<b>Protection class:</b>	I
<b>Ambient device temperature:</b>	–10... +55°C, 1 or 2 microswitches as potential-free changeover contacts
<b>Ambient temperature:</b>	max. 200°C
<b>Sensor:</b>	gas-filled, made of Cu, active over its entire length
<b>Colour:</b>	grey (RAL 7035) JTF-... W: grey

### TÜV type tested acc. to DIN 3440

Reg. no.: TW 65401 (JTF-1, -3, -5), STB 65501 (JTF-2, -4, -6)

### TÜV type test acc. to DIN EN 14597 currently performed

### Note:

The installation clips, the dip sleeves and the protective spiral are not included in the scope of the delivery and need to be ordered separately.

## Application

Especially suited to ensure the protection of hot water coil heating systems against freezing. The frost protection thermostat models JTF-21 to JTF-25 are equipped with two switching outputs that provide the option to act on the system already in advance of the attaining of the corresponding danger point. All devices are fail-safe and dispose of a lead-sealable set value setting facility.

In each case, the capillary tubes are active over their entire length. The device responds if the adjusted scale value is attained over a length of approx. 30 cm 60 cm respectively (with 12 m variants).

### JTF-1 bis -25:

Specially suited for the measuring of temperatures in non-aggressive gases. The bracing of the capillary tubes in front of the coil heating system can be realised by means of installation clips (JZ-05 / 6M (metal) or JZ-05 / 06 K (plastic)).

### JTF-3 / -4 (additional application):

The protective spiral SW-200-12 is determined for use with all temperature measuring tasks within non-aggressive types of gas that flow in conduits, while the dip sleeve TH-140 is determined for all measuring tasks within non-aggressive fluids. The application of the dip sleeve type NTH-140 is required when using the device for the measuring of temperatures in aggressive fluids.

Type	Item No.	Length of capillary	Equipment	Sensor bulb	PG
<b>One-stage</b>					
JTF-1	E 6090301	6.0 m			C
JTF-1 / 12	E 6090328	12.0 m			C
JTF-1W	E 6090014	6.0 m	IP 65		C
JTF-2	E 6090308	6.0 m	external manual reset		C
JTF-2 / 12	E 6090329	12.0 m	external manual reset		C
JTF-3	E 6090309	1.8 m	also for use on the water side	9.5 x 76 mm	C
JTF-3 W	E 6090065	1.8 m	IP 65, also for use on the water side	9.5 x 76 mm	C
JTF-4	E 6090310	1.8 m	external manual reset, also for use on the water side	9.5 x 76 mm	C
JTF-5	E 6090311	3.0 m			C
JTF-6	E 6090040	3.0 m	external manual reset		C
<b>2-stage: 1st stage emits a signal at 5 K before the attaining of the switch-off point</b>					
JTF-21	E 6090320	6.0 m			C
JTF-21 / 12	E 6090330	12.0 m			C
JTF-21W	E 6090283	6.0 m	IP 65		C
JTF-22	E 6090322	6.0 m	external manual reset		C
JTF-22 / 12	E 6090321	12.0 m	external manual reset		C
JTF-25	E 6090324	3.0 m			C

**Accessories:** Installation clips (page 159 – 160), dip sleeves (page 156), protective spiral (page 154)

# Frost protection thermostat JTF-1 ... -25

Capillary system, 1 or 2 stages, TÜV tested , switching type

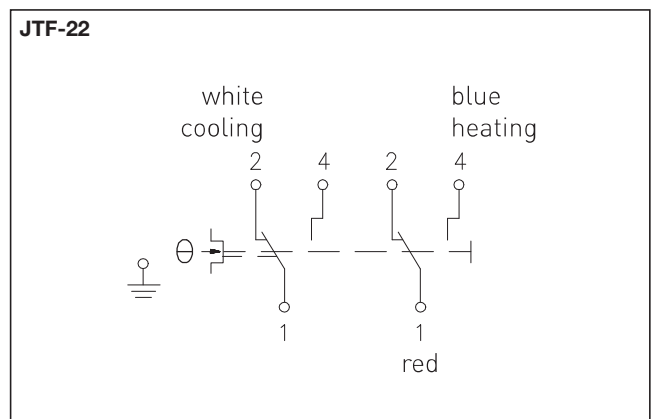
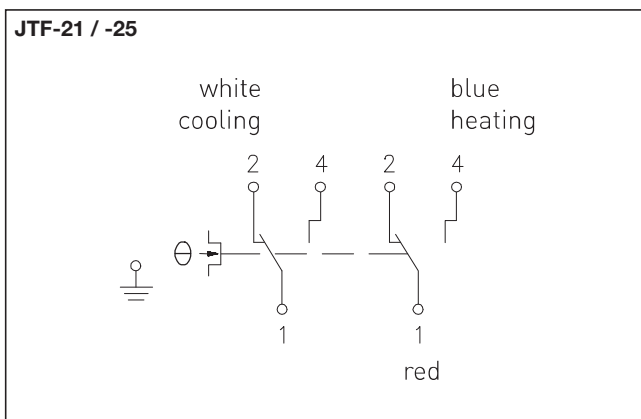
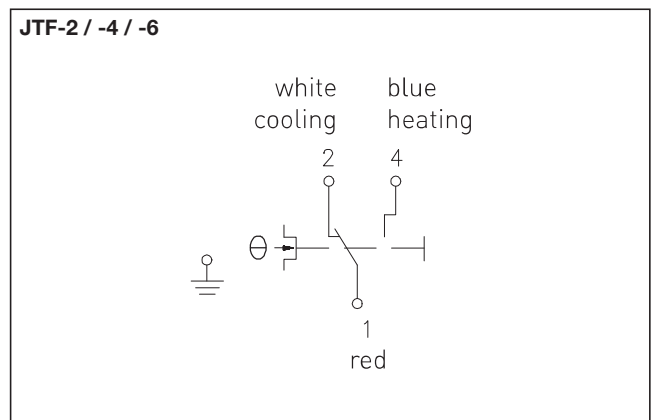
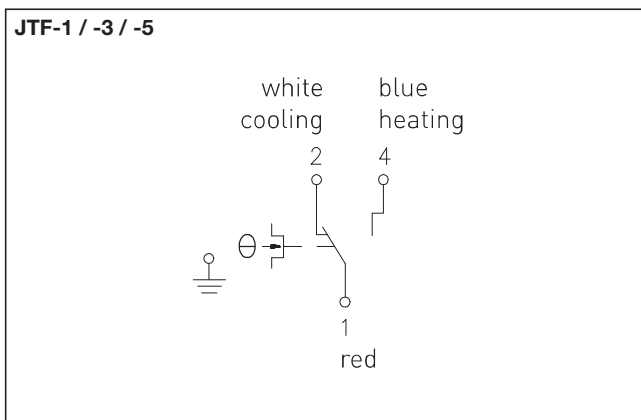
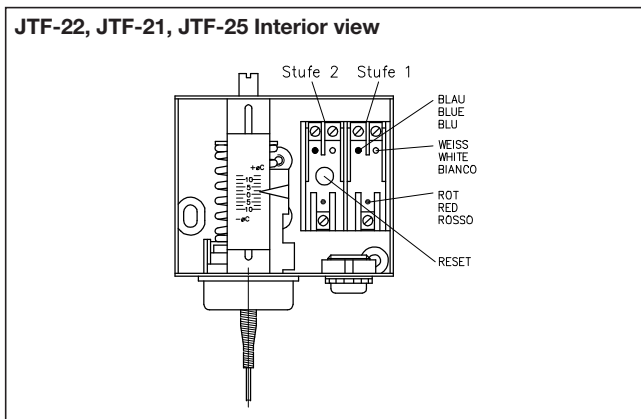
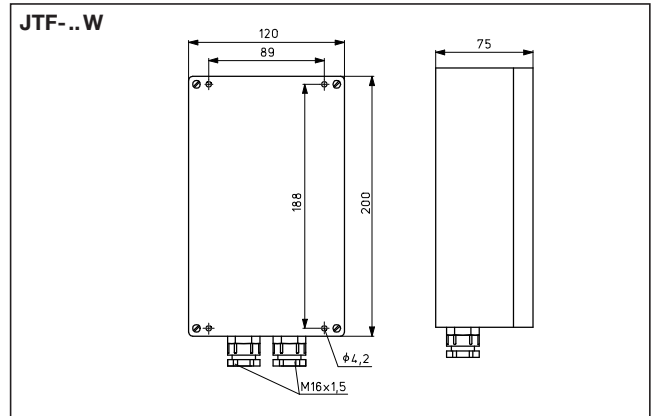
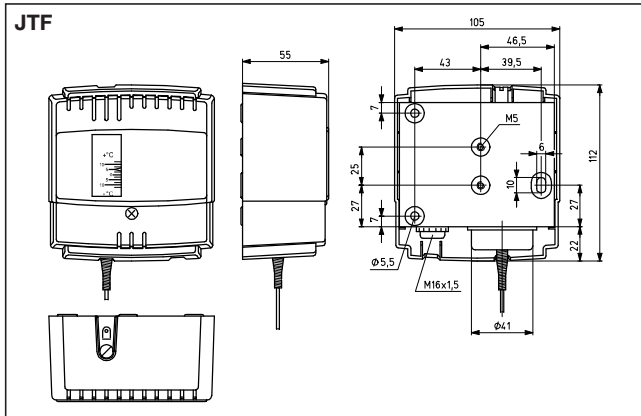

# Frost protection thermostat JTF-31, JTF-35

Continuous and switching



### Technical data

<b>Operating voltage:</b>	15 ... 36 V = / 24 V~
<b>Measuring range:</b>	0 ... 15°C
<b>Output (continuous):</b>	0 ... 10 V (corresponds to 0 ... 15°C)
<b>Output (switching):</b>	setting range 0 ... 10 °C
<b>Switching capacity:</b>	1 (0.2) A, max. 30 V ~ / 120 V =, safety extra low voltage (SELV)
<b>Switching difference of the switching output:</b>	approx. 2 K
<b>Contact:</b>	1 relay as potential-free changeover contact
<b>Switching difference of the switching output:</b>	± 1.0 K (at 10°C)
<b>Ambient temperature:</b>	<b>Capillary tube:</b> -20 ... +110°C (capillary tube > 20 cm away from the housing) <b>Housing:</b> -15 ... +50°C
<b>Degree of protection:</b>	IP 65
<b>Protection class:</b>	III
<b>Colour:</b>	grey (bottom part RAL 7016, upper part RAL 7035)

### Application

For the supervision and protection of hot water coil heating systems or heat exchangers installed in ventilating-, heating or air conditioning system. Also suited for the measuring of temperatures in non-aggressive types of gas.

The bracing of the capillary tubes in front of the coil heating system can be realised by means of installation clips (JZ-05 / 6M (metal) or JZ-05 / 06 K (plastic).

**Installation clips are not included in the scope of the delivery and need to be ordered separately (see page 159 to 160).**

Type	Item No.	Continuous and switching	Equipment	PG
JTF-31	G 8000404	6.0 m	0 – 10 V output and changeover contact	J
JTF-35	G 8000405	3.0 m	0 – 10 V output and changeover contact	J

Accessories	PG
JTF-H	J

**Functional description:** The temperature sensed within a range from 0 ... + 15°C is being translated into a voltage signal of 0 to 10 V and being output. This voltage is made available at the terminal "Temp". An internal setting facility provides the option to adjust the switching point of a potential-free changeover contact within a range from 0 ... + 10°C in addition. In the event this switching point is underrun, the relay output switches over to "frost protection" (contact "W" connected with contact "B"). An internal plug-in bridge enables to select between the operating modes "automatic" or "manual". In the event the temperature rises by more than 2 K above the adjusted switching point, the device changes, while operating in automatic mode, over to normal mode operation. In this case, the relay drops back to its initial position (contact "W" connected with contact "A"). If the temperature rise by more than 2 K occurs while operating in manual mode, the internal reset key must be actuated manually to trigger a reset or simply by disconnecting the operating voltage supply manually (relay drops back to its initial position, the contact "W" is connected with contact "A"). The control input "ST-E" enables to effect a displacement of the characteristic curve.

**Caution:** The capillary sensor is active over its entire length. The device responds if the capillary sensor senses the temperature change over a distance of approx. 25 cm.

**Heating resistor:** The housing of the frost protection thermostat must be mounted in such manner that it is not exposed to any temperatures below the adjusted switching threshold "FS" (frost protection) or that it is, over the entire length of its capillary sensor, not exposed to any temperatures below the admissible minimum temperature, as this would trigger a false trip. If it was impossible to avert the described condition, the heating resistor JTF-H (to be ordered separately) needs to be fitted between the operating voltage terminals.

